

AMS™



AMS 800™

Urinary Control System

For Male, Female, and Pediatric Patients

Operating
Room Manual

English

Va
Förä
Günce

Остаряла версия. Да не се използва.
Zastaralá verze. Nepoužívat.
Forældet version. Må ikke anvendes.
Version überholt. Nicht verwenden.
Aegunud versioón. Árgе kasutage.
Παλιά έκδοση. Μην την χρησιμοποιείτε.
Outdated version. Do not use.
Versión obsoleta. No utilizar.
Zastarjela verzija. Nemojte upotrebljavati.
Úreлт útgáfa. Notið ekki.
Versione obsoleta. Ne pas utiliser.
Zastarjela verzija. Nenaudokite.
Novecoјusi versija. Non utilizzare.
Elavult verzió. Ne használja!
Dit is een verouderde versie. Niet gebruiken.
Wersja przeterminowana. Nie używać.
Versão obsoleta. Não utilize.
Versiune expirată. A nu se utiliza.
Zastarana verzija. Nepoužívať.
Vanhentunut versio. Älä käytä.
Föråldrad version. Använd ej.
Güncel olmayan sürüm. Kullanmayın.

TABLE OF CONTENTS

CONTENTS

DISCLOSURES

Indications For Use	1
Contraindications	1
Warnings	1
Precautions	2
Patient-Related	2
InhibiZone Related	3
Surgery-Related	3
Device-Related	4
InhibiZone™	
Antibiotic Surface Treatment	4

DEVICE DESCRIPTION

System Description	5
System Operation	5
Components	6
Packaging	6
Individual Components	6
Occlusive Cuff	6
Pressure-Regulating Balloon	7
Control Pump	7
Accessory Kit	8
Connectors	9
Quick Connect Assembly Tool (Optional)	9
Tubing Passers (Optional)	9
Deactivation Kit	9

DEVICE STERILIZATION AND STORAGE

Care and Storage of Presterilized Components	10
Sterilization	10
How to Sterilize AMS Tools	10
Component Resterilization	10

SURGICAL PREPARATION

Operating Room Preparation	11
Preoperative Surgical Team Preparation	11
Preoperative Patient Preparation	11
Supplies and Instrument Requirements	12
Open Components	13
Prepare Hemostats	14
Prepare System Components	14
Filling Solutions	14
Prepare Control Pump	16
Prepare Pressure-Regulating Balloon	17
Prepare Cuff	18

BULBOUS URETHRA CUFF PLACEMENT

Surgical Procedures	20
Bulbous Urethra Cuff Placement - Perineal Approach	20
Implant Pressure Regulating Balloon	21
Implant Pump	22
Connect Tubing	22
Deactivate	22
Bulbous Urethra Cuff Placement -	

Transverse Scrotal Approach	23
Implant Pressure Regulating Balloon	25
Implant Pump	26
Connect Tubing	26
Deactivate	26
Attaching a Second Cuff to the System	27
Components and Accessories	28
Choose the Correct Size of Cuff	28
Fill the Components	28
Place a Second Cuff	28
Connect Tubing	29
Deactivate	29

BLADDER-NECK CUFF PLACEMENT

Bladder-Neck Cuff Placement	30
Implant Pressure Regulating Balloon	30
Implant Pump	31
Connect Tubing	31
Deactivate	31
Transvaginal Approach	31

CONNECT TUBING

Connect Tubing	32
Using AMS Quick Connect Sutureless Window Connectors	32
Using AMS Suture-Tie Connectors	33
Deactivation Kit	35

DEVICE OPERATION

Deactivate Cuff	36
Activate (Reactivate) Cuff: Normal Method	36
Activate (Reactivate) Cuff: Optional Methods	37
Side Squeeze Method	37
Cotton Swab Method	37
Valve Block Bending Method	37

POST OPERATIVE CARE

Immediately Postoperative	38
After Release From Hospital	38
Evaluating Long-Term Function and Placement	38

DOCUMENTATION

Completing the Patient Information Form	39
Inventory Returns and Replacement Information	39
Document Information	39

TROUBLESHOOTING

Total Device	40
Occlusive cuff	40
Pressure-Regulating Balloon	40
Control Pump	40

Остаряла версия. Да не се използва.
Zastaralá verze. Nepoužívat.
Forældet version. Må ikke anvendes.
Version überholt. Nicht verwenden.
Aegunud versioón. Árgе kasutage.
Παλιά έκδοση. Μην την χρησιμοποιείτε.
Outdated version. Do not use.
Versión obsoleta. No utilizar.
Zastarjela verzija. Nemojte upotrebljavati.
Úreлт útgáfa. Notið ekki.
Versione obsoleta. Ne pas utiliser.
Zastarjela verzija. Nenaudokite.
Novecoјusi versija. Non utilizzare.
Elavult verzió. Ne használja!
Dit is een verouderde versie. Niet gebruiken.
Wersja przeterminowana. Nie używać.
Versão obsoleta. Não utilize.
Versiune expirată. A nu se utiliza.
Zastarana verzija. Nepoužívat.
Vanhentunut versio. Älä käytä.
Föråldrad version. Använd ej.
Güncel olmayan sürüm. Kullanmayın.

DISCLOSURES

This section lists the following disclosures:

- Indications For Use
- Contraindications
- Warnings
- Precautions

INDICATIONS FOR USE

The AMS 800 is used to treat urinary incontinence due to reduced urethral/bladder outlet resistance (intrinsic sphincter deficiency) in males, females and children.

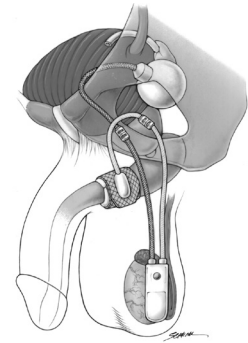

Figure 1-1.
AMS 800 implanted
in a male patient

CONTRAINDICATIONS

1. This device is contraindicated in patients whom the physician determines to be poor candidates for surgical procedures and/or anesthesia due to physical or mental conditions.
2. This device is contraindicated in patients with urinary incontinence due to or complicated by an irreversibly obstructed lower urinary tract.
3. This device is contraindicated in patients with irresolvable detrusor hyperreflexia or bladder instability.
4. The implantation of the InhibiZone™ version of this device is contraindicated in patients with known allergy or sensitivity to rifampin or to minocycline or other tetracyclines.
5. The implantation of products with InhibiZone is contraindicated in patients with systemic lupus erythematosus because minocycline has been reported to aggravate this condition.

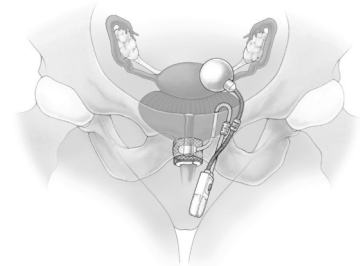

Figure 1-2.
AMS 800 implanted
in a female patient

WARNINGS

1. Patients with urinary tract infections, diabetes, spinal cord injuries, open sores, or skin infections in the region of the surgery have an increased risk of infection associated with a prosthesis. Appropriate measures should be taken to reduce the likelihood of infection. Infection that fails to respond to antibiotic therapy may result in removal of the prosthesis. Infection followed by explantation of the device may result in scarring which may make subsequent reimplantation more difficult.
2. Erosion may be caused by infection, pressure on the tissue, improper cuff sizing, improper balloon selection, tissue damage, and component misplacement. The cuff may erode around the urethra or bladder neck. The control pump

DISCLOSURES (CONTINUED)

may erode through the scrotum. The pressure-regulating balloon may erode into the bladder. Acute urinary tract infection can interfere with proper functioning of the device and may lead to erosion of the urethra in the cuff area. Failure to evaluate and promptly treat the erosion may result in a substantial worsening of the condition leading to infection and/or loss of tissue.

3. Poor bladder compliance or a small fibrotic bladder may require some measure of intervention including, in some cases, augmentation cystoplasty before implanting the prosthesis.
4. Patients with urge incontinence, overflow incontinence, detrusor hyperreflexia or bladder instability should have these conditions treated and controlled (or resolved) prior to implantation of the device.
5. Do not pass a catheter or any other instrument through the urethra without first deflating the cuff and deactivating the device to prevent potential damage to the urethra or the AMS 800.
6. This device contains solid silicone elastomers. This device does not contain silicone gel. The risks and benefits of implanting this device in patients with documented sensitivity to silicone should be carefully considered.
7. Surgical, physical, psychological, or mechanical complications, if they occur, may necessitate revision or removal of the prosthesis. Removal of the device without timely reimplantation of a new device may complicate subsequent reimplantation. The timing of reimplantation should be determined by the treating physician based on the patient's medical condition and history.
8. Product wear, component disconnection or other mechanical problems may lead to surgical intervention. Mechanical complications may include malfunctioning of the components and leakage of fluid. Any mechanical malfunction that does not permit the transfer of fluid from the cuff to the balloon may result in overflow obstruction. Mechanical events should be evaluated carefully by the treating physician and the patient should consider risks and benefits of treatment options, including revision surgery.

9. Previous patient history of adverse reaction(s) to radiopaque solution precludes its use as a filling medium for the prosthesis. Instead, saline should be used to fill the device.
10. Female patients with persistent incontinence should be evaluated to rule out vesicovaginal fistula, which may have resulted from an unrecognized iatrogenic injury.
11. If a hypersensitivity reaction develops to a device coated with InhibiZone, the cuff and pump should be removed and the patient treated appropriately.

PRECAUTIONS

Patient-Related

1. Patient selection requires thorough preoperative consultation and evaluation by the physician.
2. Patients should be counseled in order to have a realistic expectation of the physical, psychological, and functional outcome of the implantation of an AMS 800. Although the prosthesis is designed to restore urinary control, some patients continue to have a degree of incontinence after this procedure.
3. Patients may experience pain when the device is activated in the postoperative period and during periods of initial use. Cases of chronic pain associated with device have been reported. Pain with a severity or duration beyond what is expected may require medical or surgical intervention. Patients should be counseled on expected postoperative pain including severity and duration.
4. Tissue fibrosis, previous surgery, or previous radiation therapy in the area of the implant may preclude implantation of a cuff at the bulbous urethra or bladder neck.
5. Any progressively degenerative disease, e.g. multiple sclerosis, may limit the future usefulness of the implanted prosthesis as a treatment for the patient's urinary incontinence.
6. Adequate manual dexterity, strength, motivation, and mental acuity are required for proper use of the device.

DISCLOSURES (CONTINUED)

7. Trauma or injury to the pelvic, perineal or abdominal areas, such as impact injuries associated with sports, can result in damage to the implanted device and/or surrounding tissues. This damage may result in the malfunction of the device and may necessitate surgical correction including replacement of the prosthesis. The physician should advise patients of these possibilities and warn them to avoid trauma to these areas.
8. Female patients of child-bearing age must be forewarned that pregnancy is acceptable, but cesarean section may be indicated to minimize the risk of damage to the bladder neck and its surrounding cuff. For those patients who become pregnant, deactivation of the device during the third trimester is recommended to reduce the risk of erosion. Those patients contemplating pregnancy should consider delaying implantation.
9. Children receiving device should be evaluated at regular intervals. Lifelong radiological and urodynamic surveillance of the urinary tract is crucial. Before implantation, the patient and their family should be informed of the complication rate and the need for long-term follow-up.
10. Consideration should be given to the diameter of the implanted occlusive cuff relative to catheters or other trans-urethral devices. When fully deflated, the inside diameter of the smallest occlusive cuff (3.5cm) generally exceeds 28F. Additional clearance is required to accommodate the patient's urethral tissue between the trans-urethral device and the occlusive cuff. Urethral tissue thickness is patient specific and requires a physician's assessment to determine its impact on sizing.
3. Patients who receive a device with InhibiZone and are also taking Warfarin should have their prothrombin time monitored because tetracyclines have been reported to slow coagulation.
4. Use of products with InhibiZone should be carefully considered in patients using thionamides, isoniazid and halothane, due to potential hepatic side effects that have been reported in patients using these drugs and higher doses of rifampin (rifampicin).
5. Devices with InhibiZone should not come into contact with ethyl alcohol, isopropyl alcohol or other alcohols, acetone or other non-polar solvents. These solvents may remove the antibiotics from the device.
6. InhibiZone components should not be soaked in saline or other solutions prior to implantation. The components may be briefly rinsed or dipped into a sterile solution, immediately prior to implant, if desired.
7. InhibiZone does not replace your normal antibiotic protocols. Continue using any prophylactic protocols normally used for urological surgical procedures.
8. Because products with InhibiZone are impregnated with a combination of rifampin (rifampicin) and minocycline, the contraindications, warnings and precautions regarding the use of these antimicrobial agents apply and should be adhered to for the use of this device, although systemic levels of minocycline and rifampin (rifampicin) in patients receiving this device are unlikely to be detected.

Surgery-Related

InhibiZone Related

1. Use of products with InhibiZone should be carefully considered in patients with hepatic or renal disease, as use of rifampin (rifampicin) and minocycline can cause additional stress on the hepatic and renal systems.
2. Patients who receive a device with InhibiZone and are also taking methoxyflourane should be carefully monitored for signs of renal toxicity.
1. Improper cuff sizing, improper balloon selection, or other causes may result in tissue erosion, migration of components, or continued incontinence.
2. Component migration can occur if the cuff is sized improperly, if the pump or balloon is not positioned correctly, or if the tubing lengths are incorrect. Migration can result in pain, complications, device malfunction and surgical revision.

3. Unsuccessful outcomes may result from improper surgical technique, improper sterile technique, anatomical misplacement of components, improper sizing and/or filling of components.
4. Although reinforced tubing has been designed to be more resistant to tubing kinks, tubing kinks may still result from tailoring the connecting tubing to an improper length during the implant procedure.

Device-Related

1. If the deactivation valve is closed when the cuff is inflated, fluid cannot transfer from the cuff to the balloon and sustained outflow obstruction may arise as a result:
 - a. In the event of large pressures within the bladder, automatic pressure relief that normally occurs with the device would be prevented. Cycling the device can relieve the outflow obstruction.
 - b. Cycling the device may be difficult if deactivation occurs when the pump bulb is deflated. If unable to cycle the prosthesis, squeezing the sides adjacent to the deactivation button will allow fluid to fill the pump bulb and then the pump can be cycled normally.
 - c. Release of the deactivation valve may require greater pressure than that used to cycle the device.
2. System pressure changes may occur over time if you fill the balloon with radiopaque solution of incorrect concentration. Follow the instructions in the Operating Room Manual to prepare the radiopaque solution with the correct concentration.

INHIBIZONETM ANTIBIOTIC SURFACE TREATMENT

American Medical Systems has a proprietary process to impregnate antibiotics into the tissue-contacting surfaces of the urinary control system. This InhibiZone Antibiotic Surface Treatment innovation is intended to elute the antibiotics from the device surface when exposed to a warm, moist environment. In *in vitro* testing using susceptible organisms, this elution provided antibiotic action both on the surface and in a zone surrounding the treated device.

Existing prophylactic antibiotic protocols should be maintained as determined by the physician and or institution.

The AMS patented antibiotic surface treatment process uses a formulation of minocycline Hydrochloride and rifampin (rifampicin). A system implant contains less than 2% of the oral dose exposure during a complete course of rifampin and minocycline, even if two of the largest size Cuffs are implanted. The average amounts of rifampin and minocycline contained on a prosthesis implant are represented by the means and 95% tolerance intervals of the following implant configurations:

- 1.9 mg rifampin (0.7 – 3.1 mg) and 2.8 mg minocycline (2.1 – 3.5 mg) for the implant configuration with the lowest drug levels, i.e., single 4.0 cm cuff + control pump
- 3.7 mg rifampin (0.9 – 6.5 mg) and 6.3 mg minocycline (4.7 – 8.0 mg) for the implant configuration with the highest drug levels, i.e., double 11.0 cm cuff + control pump

In vitro studies with the antibiotic treated device material and susceptible strains of *Staphylococcus epidermidis* and *Staphylococcus aureus* show a microbial “zone of inhibition” around the test material. The clinical significance of these *in-vitro* data is unknown. A limited animal model study suggests that this surface treatment may reduce the potential for bacterial colonization of the treated device.

No clinical studies have been performed to evaluate the effect of the antibiotic surface treatment reducing the incidence of sphincter implantation infections.

DEVICE DESCRIPTION

SYSTEM DESCRIPTION

The AMS 800 prosthesis consists of three components: an occlusive cuff, a control pump, a pressure-regulating balloon, and connectors. The cuff can be implanted at either the bulbous urethra (**Figure 1-1**) or bladder neck (**Figure 1-2**) in men and adolescent males. In females and children, the cuff is placed at the bladder neck. (**Figure 1-2**)

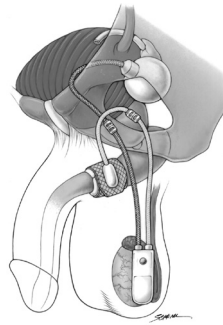

Figure 1-1.
AMS 800 implanted
with cuff at
bulbous urethra

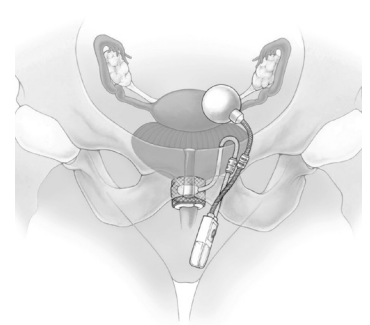

Figure 1-2.
AMS 800 implanted
with cuff at
bladder neck

SYSTEM OPERATION

The AMS 800 simulates normal sphincter function by opening and closing the urethra at the control of the patient. When the cuff is closed, urine stays in the bladder. (**Figure 2-1a**)

When the patient wishes to void, he or she squeezes and releases the pump, implanted in the scrotum or labium, several times. This causes the fluid in the cuff to move from the cuff into the pressure-regulating balloon. The cuff opens and urine passes through the urethra. (**Figure 2-1b**) The balloon then automatically repressurizes the cuff due to the automatic returning of the fluid by the pressure-regulating balloon to the cuff. (**Figure 2-1c**)

The control pump is designed to allow the urologist to deactivate the implanted device without additional surgery (see instructions on how to Deactivate the Cuff).

System Operation Shown in a Male

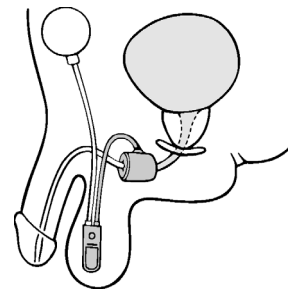

Figure 2-1a. Urethra closed by cuff

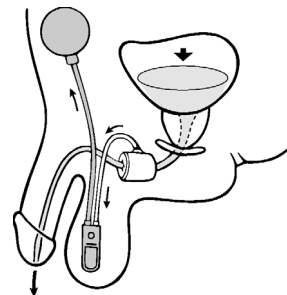

Figure 2-1b. Opening of cuff and
urination by manipulation of pump

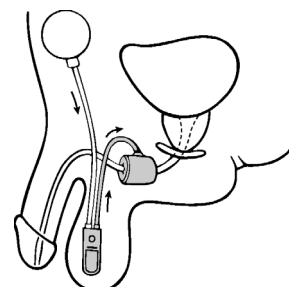

Figure 2-1c. Automatic cuff re-closure

DEVICE DESCRIPTION (CONTINUED)

COMPONENTS

This section provides a brief description of the following AMS 800 Urinary Control System components and accessories:

- ✓ Occlusive Cuff
- ✓ Pressure-regulating Balloon
- ✓ Control Pump
- ✓ Accessory Kit (Including Connectors)
- ✓ Quick Connect Assembly Tool (Optional)
- ✓ Tubing Passers (Optional)
- ✓ Deactivation Kit (Optional)

Cuffs and pumps are available with InhibiZone™ Antibiotic Surface Treatment, which is an antibiotic surface treatment of rifampin (rifampicin) and minocycline.

Packaging

All components and accessories are sterilized products, except for the non-sterilized designated tools (Quick Connect Tool and tubing passers). Each sterile component is packaged separately within an inner plastic tray which is sterile and sealed with a Tyvek™¹ lid. The inner tray lies within the sterile environment of a plastic outer tray which is also sealed by a Tyvek lid. This double package is further protected by an outer box for transportation. Adhesive labels on one end of the outer box and on the Tyvek lid of the outer tray identify the components, their sizes, and serial and lot numbers.

INDIVIDUAL COMPONENTS

Occlusive Cuff

Implanted at either the bulbous urethra (male) or the bladder neck (males, females, children), the occlusive cuff occludes the urethra by applying pressure circumferentially. It is made of silicone elastomer and is available in thirteen sizes ranging from 3.5 cm to 11 cm in length (all cuffs are approximately 1.8 cm wide when deflated). The surgeon determines the proper size to be used in the patient by measuring the circumference of the tissue around the urethra intraoperatively. The cuff tubing is joined to the control pump tubing with a connector.

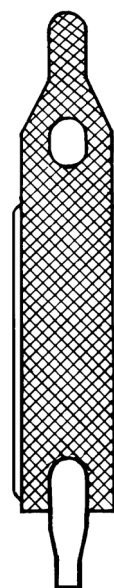

← Figure 2-2.
Occlusive
Cuff

¹ Tyvek™ is a registered trademark of E.I. DuPont de Nemours and Company

DEVICE DESCRIPTION (CONTINUED)

Pressure-Regulating Balloon

The pressure-regulating balloon, implanted in the prevesical space, controls the amount of pressure exerted by the occlusive cuff. It is also made of silicone elastomer and is provided in the following six ranges.

• 51-60 cm H ₂ O	• 41-50 cm H ₂ O
• 61-70 cm H ₂ O	• 81-90 cm H ₂ O
• 71-80 cm H ₂ O	• 91-100 cm H ₂ O

Upon activation the balloon pressure will be within the stated range. The surgeon usually selects the lowest balloon pressure needed to maintain closure of the bladder neck or bulbous urethra. The balloon's tubing is also linked to tubing from the control pump by a connector.

Figure 2-3.
Pressure-Regulating Balloon

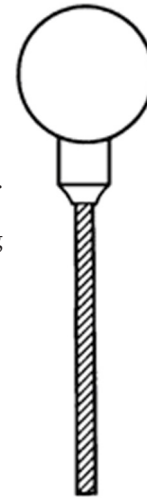

Control Pump

The control pump is implanted in the soft tissue of the scrotum or labium. It is approximately 1.3 cm wide and 3.5 cm long. The upper part of the control pump (the valve block) contains the resistor and valves needed to transfer fluid between the components. The bottom half of the control pump is a bulb that the patient squeezes and releases to transfer fluid in order to void.

The deactivation button is located in the upper portion of the control pump. When the deactivation button is pressed, it stops fluid from being transferred between the components. This feature allows the physician to leave the cuff open:

- During the postoperative healing period
- For transurethral procedures

The AMS 800 has color-coded tubing to help surgeons make the correct connections between the components:

- Clear tubing connects to cuff
- Black tubing connects to balloon

The tubes are connected with connectors. There are two types of connectors: AMS straight or curved Quick Connect Sutureless Window Connectors. They may also be made with straight or curved suture connectors, which are secured with 3-0 polypropylene (non-absorbable) ties.

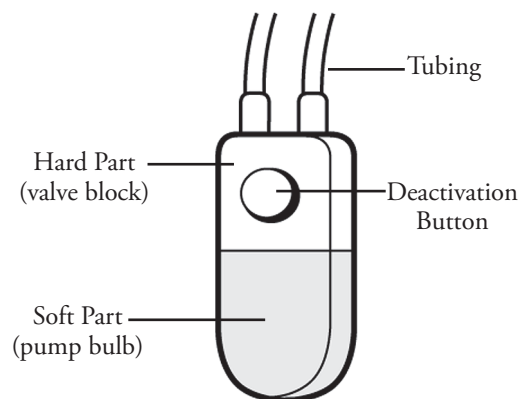

Figure 2-4.
Control Pump

DEVICE DESCRIPTION (CONTINUED)

Accessory Kit

The Accessory Kit for the AMS 800 contains accessory materials necessary for one implant procedure. The Accessory Kit includes the following disposable items:

- Cuff Sizer (**Figure 2-5**)
 - One disposable cuff sizer
- Special Purpose Needles (**Figure 2-6**)
 - Two 15-gauge blunt needles (for filling components)
 - Two 22-gauge blunt needles (for flushing the opening of the tubing and inside of the connectors)
- Protection Tubes
 - Two 30 cm lengths of silicone tubing (for covering the tips of the hemostats used to prepare components—to protect the tubing from damage by the hemostat jaws.)
- Tubing Connectors and Collets
 - Three straight suture-tie connectors
 - Two right angle suture-tie connectors
 - One 3-way suture tie connector (Y-connector)
 - Three straight quick-connect window connectors
 - Two right angle quick-connect window connectors
 - One 3-way quick-connect window connector (Y-connector)
 - Eight collets (on a collet holder, used with Quick Connectors).



Figure 2-5. Cuff Sizer



Figure 2-6. Blunt-Tip Needles

The Cuff Sizer measures the urethral circumference. When selecting a cuff size, the cuff length refers to the outside diameter of the cuff when it encircles the urethra.

Note: The inside circumference of the cuff is somewhat smaller than the outside circumference of the cuff.

Use the 15-gauge needles to fill the components. They fit snugly into the lumen of the tubing to prevent fluid from leaking during the filling process. The 22-gauge needles are small enough to fit within the tubing to flush away air and blood before a connection is made.

Place the extra silicone tubing found in the Accessory Kit over the tips of the hemostats used for clamping tubing or handling device components (see Preparing Hemostats).

DEVICE DESCRIPTION (CONTINUED)

Connectors

Two systems for connecting components and tubing are available for the AMS 800.

- Suture-Tie Connectors
- Quick-Connectors

The Accessory Kit contains three straight and two right angle AMS Suture-Tie Connectors and one 3-way “Y” connector. (Figure 2-7) These connectors are attached with permanent, non-absorbable sutures (3-0 polypropylene).

The Accessory Kit also contains AMS Quick Connect Sutureless Window Connectors - three straight, two right angle, and one 3-way “Y” connector (Figure 2-8), eight collets (or locking rings) (Figure 2-9) and one collet holder. To use the Quick Connectors, a Quick Connection Tool (Figure 2-10) must be ordered, which is sterilized at the site.

CAUTION: AMS Quick Connect Sutureless Window Connectors should not be used in revision procedures involving previously implanted component tubing. Changes in the tubing over time may reduce the fixation performance of the Quick Connect Sutureless Window Connectors. The Quick Connect system may be used when all previously implanted components are removed and replaced with new components.

Quick Connect Assembly Tool (Optional)

In order to use the quick-connectors in the Accessory Kit, you must order the AMS Quick Connect Assembly Tool. This is a reusable stainless steel instrument used to close the connectors. The Quick Connect Assembly Tool is shipped non-sterile and may be resterilized. Quick-connectors should not be used on revision surgeries, except when all previously implanted components are removed and replaced with new components.

Caution: Sterilize the AMS Quick Connect Assembly Tool properly before use.

Tubing Passers (Optional)

Tubing Passers (Figure 2-11) are used to route the tubing of the components from one incision site to another incision site. The machined end of the passer provides a snug fit in the tubing lumen. Tubing passers are shipped in non-sterile condition and must be sterilized before use.

Caution: Sterilize the tubing passers properly before use.

Deactivation Kit

The Deactivation Kit is an optional package not normally required for an initial implant. It contains 3 stainless steel plugs and 1 straight suture-tie connector (Figure 2-12). The 3 plugs are often useful during revision surgical procedures to protect the inside of the preserved components and the fluid from contamination.

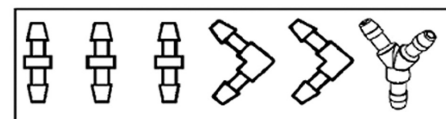

Figure 2-7. Suture Tie Connectors



Figure 2-8. Quick Connect Sutureless Window Connectors

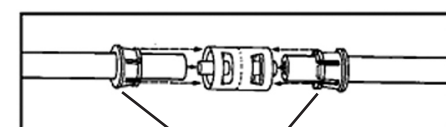

Figure 2-9. Collets

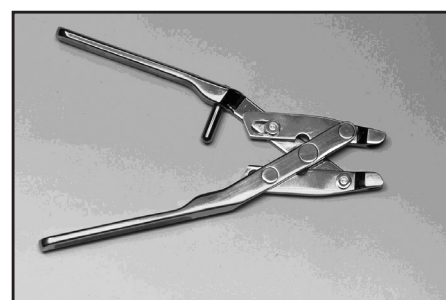

Figure 2-10. Quick Connect Assembly Tool



Figure 2-11. Tubing Passers

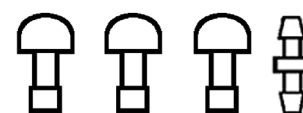

Figure 2-12. Deactivation Kit

DEVICE STERILIZATION AND STORAGE

CARE AND STORAGE OF PRESTERILIZED COMPONENTS

All the components and accessories of this device are sterilized products. Use before the expiration date of the sterilized products.

CAUTION: Designated tools such as the Quick Connect Tool and tubing passers are shipped without sterilization. Re-sterilize them before each use.

To protect the integrity of the packaging and function of the AMS 800 prosthesis, store the presterilized components on a protected shelf or in a cabinet. The environment should be clean, dry, and near room temperature. For maximum protection during storage, leave the component trays within their dustcover boxes.

- Store in a clean, dark, and cool place.
- Avoid water, direct sunlight, high temperatures, humidity, and ultraviolet light.
- Avoid abnormal altitudes, temperatures, humidity, aeration, sunlight, dust, salt and ions in the air.
- Do not store in a place where there are chemicals or gas.

The versions of the AMS 800 components with InhibiZone Antibiotic Surface Treatment are light and temperature sensitive. Care should be taken to store the products according to the instructions on the package.

CAUTION: Do not store products with InhibiZone above 40°C (104°F).

CAUTION: Do not use this product past its expiration date.

STERILIZATION

How to Sterilize AMS Tools

American Medical Systems does not sterilize the AMS Tubing Passers or the AMS Quick Connect Assembly Tool. These instruments are shipped in steam sterilization packages ready for hospital sterilization.

Before using, sterilize the optional Tubing Passers and Quick Connector Assembly Tool by steam autoclave at 120 to 123 degrees C for 20 minutes or by Prevac steam autoclave cycle at 134 to 137 degrees C for 3 1/2 minutes. Thoroughly clean these instruments after each implant procedure so they will be ready for resterilization before the next implant procedure.

Component Resterilization

DO NOT re-sterilize the sterilized components or accessories. Only designated, non-sterilized tools (Tubing Passers and AMS Quick Connect Tool) can be re-sterilized.

Do not resterilize the AMS Suture-Tie Connectors or AMS Quick Connect Sutureless Window Connectors. Only the two stainless steel instruments used in conjunction with the AMS 800 prosthesis may be resterilized: the AMS Tubing Passers and the AMS Quick Connect Assembly Tool.

SURGICAL PREPARATION

OPERATING ROOM PREPARATION

Preoperative Surgical Team Preparation

Before beginning an AMS 800 implant procedure, the surgeon and the OR staff should be familiar with the device and the equipment needed as well as the steps in the procedure.

Both the surgeon and the OR staff should review the information in this manual prior to surgery. In addition, there should be an OR manual in the operating room during the surgery as a quick reference.

In many cases, it is helpful for the surgeon and/or the OR staff to observe an AMS 800 prosthesis implant surgery. This allows them to become familiar with the OR set-up and the procedure before actually being involved with one.

Just prior to surgery, the surgical team should scrub for ten minutes using povidone-iodine soap or the approved hospital scrub procedure.

Preoperative Patient Preparation

Before the surgery, many doctors prescribe prophylactic antibiotics for the patient. This is considered useful to reduce the risk of infection.

It is also important that the surgeon discuss with the patient the possibility of an allergic reaction to the materials in the device.

Scientific literature has included reports of adverse events and other observations in patients with implantable silicone devices.

As reported, these events/observations indicate “allergic-like” symptoms and, in other cases, a symptom complex associated with immunological disorders. No causal relationship has been established between these events and silicone elastomer.

Once the patient is in the operating room, the abdominal and genital area should be shaved. Following the shave, the area should be scrubbed with povidone-iodine soap for ten minutes or the approved hospital preoperative scrub procedure.

For bulbous urethra cuff placement using the perineal approach, the patient is placed in the lithotomy position, prepped, and draped for both a perineal and an abdominal incision. For bulbous urethra placement using the transverse scrotal approach, place the patient in the supine position with legs gently abducted on arm boards or other spreaders.

For bladder-neck cuff placement, the approach for male patients requires a set-up similar to that used for suprapubic prostatectomy. The patient is placed in the supine position, prepped, and draped for an abdominal incision. Access to the perineum should be maintained.

For bladder-neck cuff placement in female patients, the patient can be placed in the lithotomy or supine position, depending on the surgical approach, prepped, and draped.

SURGICAL PREPARATION (CONTINUED)

SUPPLIES AND INSTRUMENT REQUIREMENTS

A number of conventional surgical tools and supplies are needed for implantation of the AMS 800 prosthesis. Each surgeon may also have a preference about what should be available.

The following equipment, among other standard operating room materials, should be available:

- Sterile stainless steel tray
- 1000cc graduate container
- 500cc graduate container
- Sponge bowl
- Medicine cup
- Emesis basin
- Two 30cc disposable syringes
- One 10cc disposable syringe
- 8 silicone-shod hemostats
- Straight, clean and sharp scissors
- Hegar dilators
- Babcock clamps
- Asepto™ syringe
- Antibiotic solution
- Catheter
- Umbilical tape
- Vaginal pack
- Sterile saline for rinsing gloves & filling components
- Retractor (transverse scrotal approach)
- Extended nasal speculum (optional)
- Rectal tube (optional)
- Centimeter ruler (optional)

Use a plastic-draped Mayo stand or a stainless steel tray as a station for handling and filling the components of the prosthesis. Be certain that the components do not come into contact with paper or cloth drapes.

Submerge the filled components of the prosthesis in a storage basin containing sterile water until they are implanted.

Position splash basins so that the surgeons can conveniently clean their gloves during the surgical implantation procedure, especially before they make the tubing connections.

CAUTION: Be certain that the components do not come into contact with paper or cloth drapes. Fragments of these can cause possible obstruction of fluid flow if they enter the device.

SURGICAL PREPARATION (CONTINUED)

OPEN COMPONENTS

Always keep the sterile trays in their dust cover boxes when moving the components from storage to the operating room. The components should only be opened in the operating room when the surgeon directs the surgical team to do so.

Note: The AMS 800 Accessory Kit must always be opened first in order to prepare the hemostats and syringes used for preparing and filling components.

To open the components in the operating room, follow this procedure:

1. Remove trays from dust covers by opening boxes at the security tab.

Note: The circulating nurse should record the part and serial/lot numbers as well as the size of the components on the AMS Patient Information Form (PIF). Use the labels provided with the device.

Note: The adhesive label at one end of the dust cover box and the small, removable labels on the side of the plastic trays contain the name of the component (English), the part and serial/lot numbers, as well as the size of the components. This information is also listed on the lid of the outer tray (Tyvek sheet).

2. Remove inner tray from outer tray using following method:
 - Peel back lid completely from tray in one motion
 - Continue to hold outer tray without touching sterile inner tray.
 - Have scrub nurse use his or her index finger (not thumb) to carefully lift inner tray up and out of outer tray.
 - Scrub nurse should place inner tray on a plastic-draped Mayo stand in the sterile field.
3. Open inner tray just before preparing components using the following method:
 - Remove components from inner trays by peeling back lids of sterile inner trays.
 - Carefully remove components from tray.
 - Place them in their appropriate positions on plastic-draped Mayo stand.

PREPARE HEMOSTATS

To protect component tubing from being damaged by the mosquito hemostat jaws (**Figure 4-1**), cover the jaws with the silicone tubing provided in the Accessory Kit. Complete the following instructions to cover the jaws:

1. Place tubing on both jaws of hemostats up to box lock.
2. Completely cover all teeth on both jaws of six hemostats.
3. Trim tubing at jaw tip with clean, well-cutting scissors.
4. Reserve scissors for use as tubing scissors throughout procedure.

When using the hemostats, clamp jaws together only to the first click to prevent excessive pressure on tubing. (Do not advance more than one click.)

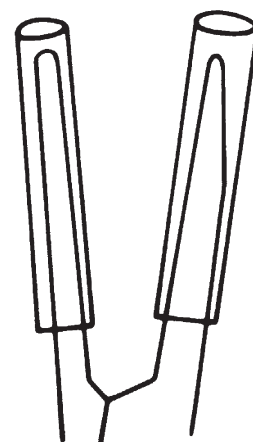

Figure 4-1. Tubing-Shod Hemostat Jaws

PREPARE SYSTEM COMPONENTS

Filling Solutions

The fluid used to fill the prosthesis must be sterile and completely free of particulate matter. The presence of any foreign materials in the fluid can affect the operation of the prosthesis. The solution must also be isotonic to minimize the transfer of fluid across the silicone membrane, which is semi-permeable. **Normal saline is the recommended isotonic solution to use when filling the prosthesis.**

However, if contrast media is preferred, one of the tested solutions in the table below may be used for filling. If you do not use the contrast media in the mixture proportions, you may alter the isotonicity of the mixtures and promote the formation of particulate matter.

Note: The products listed below are some of the radiographic solutions tested by American Medical Systems for use in AMS devices, only sterile water should be used for dilution. For a complete list contact American Medical Systems.

CAUTION: Do not use sterile saline or lactated Ringer's solution to dilute the contrast solutions.

WARNING: Contrast media are contraindicated if the patient has an iodine allergy.

The presence of particulate matter in the filling solution can affect the operation of the prosthesis. The filling solution must be free of blood and debris at all times. The solution (sterile saline) is isotonic with intracellular fluid to minimize the transfer of fluid across the semi-permeable silicone membrane.

SURGICAL PREPARATION (CONTINUED)

Contrast Media		Dilution		Manufacturer	Validated for InhibiZone Use
Conray 43	30 cc Conray 43	+	60 cc sterile H ₂ O	Mallinckrodt	Yes
Cysto Conray II	60 cc Cysto Conray II	+	15 cc sterile H ₂ O	Mallinckrodt	Yes
Hypaque-Cysto	60 cc Hypaque-Cysto	+	58 cc sterile H ₂ O	Nycomed	No
Isovue 200	60 cc Isovue 200	+	23 cc sterile H ₂ O	Bracco	No
Isovue 300	57 cc Isovue 300	+	60 cc sterile H ₂ O	Bracco	No
Isovue 370	38 cc Isovue 370	+	60 cc sterile H ₂ O	Bracco	No
Omnipaque 180	60 cc Omnipaque 180	+	14 cc sterile H ₂ O	Nycomed	No
Omnipaque 240	60 cc Omnipaque 240	+	38 cc sterile H ₂ O	Nycomed	No
Omnipaque 300	57 cc Omnipaque 300	+	60 cc sterile H ₂ O	Nycomed	Yes
Omnipaque 350	48 cc Omnipaque 350	+	60 cc sterile H ₂ O	Nycomed	No
Telebrix 12	53 cc Telebrix 12	+	47 cc sterile H ₂ O	Laboratoire Guerbel	Yes
Use an equivalent ratio dye with sterile water for a larger total volume.					

When filled, each component should be submerged in a storage basin of normal saline to prevent contact between the component and foreign materials. Be certain that the saline used as filling solution is separate from the storage basin where components are submerged after being filled and prepared.

Those components that are labeled as being treated with InhibiZone Antibiotic Surface Treatment should NOT be submerged in sterile normal saline.

CAUTION: Soaking antibiotic impregnated devices in saline will cause the antibiotics to diffuse off the device into the solution. This will cause the solution to turn orange and will reduce the concentration of antibiotics on the device.

CAUTION: It is important to maintain isotonic status of the fluid. Use sterile saline solution for primary cases. In a revision case, when radiopaque solution was used for the primary case and the surgeon preserved some of the primary components, use the same radiopaque solution at the same density. Device performance may deteriorate if different types of fluid solutions or different density solutions were mixed and the isotonicity was lost or particles were formed.

SURGICAL PREPARATION (CONTINUED)

PREPARE CONTROL PUMP

Complete the following instructions to prepare the control pump. A syringe is not necessary to fill the control pump.

1. Place end of each tubing in a basin with the appropriate filling solution. (**Figure 4-2a**)
2. Hold the pump at a 45 degree angle with the black tube on top.
3. Squeeze and release pump bulb repeatedly until all air in the pump and tubing has been displaced with fluid.

Note: It is important to keep tubing submerged during filling procedure.

Note: If air bubbles remain in pump bulb, continue to squeeze and release pump bulb to remove them; they will be evacuated through black color-coded tubing.

4. While keeping tubing submerged, use tubing-shod hemostats to clamp (one notch only) each tube 4 cm or 5 cm from end. (**Figure 4-2b**)

CAUTION: Do not advance hemostat's ratchet more than one notch. Excessive pressure will permanently damage the tubing.

Note: The clear pump tubing will connect to the clear cuff tubing, and black tubing will connected to black balloon tubing.

5. For a non Inhibizone treated pump, submerge the filled pump in a storage basin containing filling solution until implantation.
6. For a pump treated with Inhibizone Antibiotic Surface Treatment, place the pump onto an empty sterile tray or kidney basin and cover with a sterile drape. Prior to implanting, the pump should be inspected for entrapped air.

CAUTION: Soaking antibiotic impregnated devices in saline will cause the antibiotics to diffuse off the device into the solution. This will cause the solution to turn orange and will reduce the concentration of antibiotics in the device.

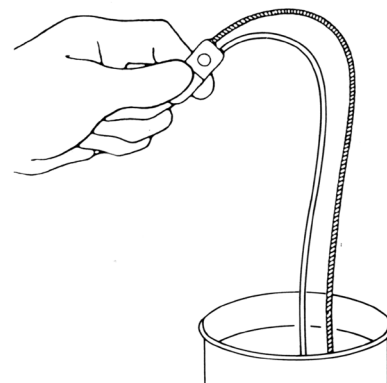

Figure 4-2a. Place Ends of Both Tubes Into Filling Solution

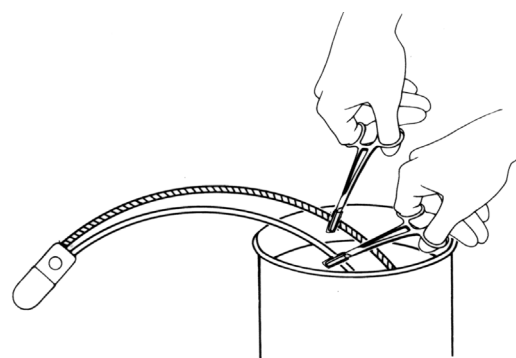

Figure 4-2b. Clamp Tubing With Ends In Filling Solution

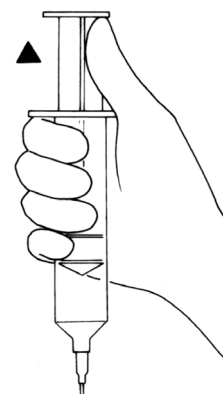

Figure 4-3a. Aspirate Air

PREPARE PRESSURE-REGULATING BALLOON

Complete the following instructions to prepare the Pressure-Regulating Balloon (PRB):

1. Attach 15-gauge blunt tip needle to 30 cc syringe.
2. Fill syringe with approximately 25 cc of filling solution.
3. Hold air-filled balloon with one hand and squeeze it until it is deflated.
4. Insert needle into end of balloon tubing.
5. Aspirate any air left in balloon until you feel resistance on syringe plunger. (**Figure 4-3a**)

Note: Always hold syringe upright: that is, needle pointing down, plunger pointing up.

6. Fill balloon with 20 cc of filling solution. (**Figure 4-3b**)
7. Rotate balloon until all air bubbles are gathered into one bubble. (**Figures 4-3c and 4-3d**)
8. Hold balloon by tubing to draw air bubble into tubing adapter area.
9. Aspirate air first, and then all fluid with syringe held upright until all air has been removed from balloon. Check that no air remains in balloon or tubing.

CAUTION: Do not over-aspirate pressure-regulating balloon because air can be drawn into system through semi permeable silicone membrane.

10. Hold plunger upright to maintain pressure.
11. Clamp tubing (one notch only) with tubing-shod hemostat 3 cm below the needle. (**Figure 4-3e**)

CAUTION: Do not advance hemostat's ratchet more than one notch. Excessive pressure will permanently damage the tubing.

12. Submerge empty balloon in a storage basin containing filling solution until implantation.

CAUTION: Do not place any hemostats on top of balloon. Any instruments on the balloon can damage it.

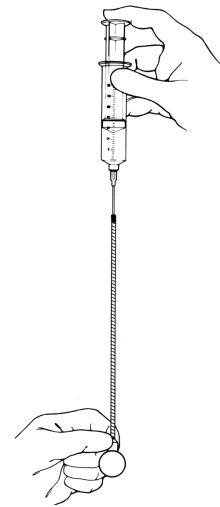

Figure 4-3b. Fill Balloon

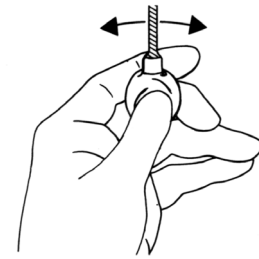

Figure 4-3c. Rotate Balloon



Figure 4-3d. Collect Air Bubbles Into One

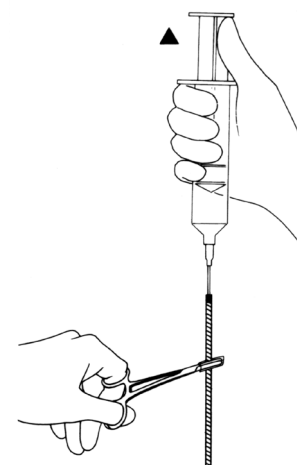

Figure 4-3e. Clamp Tubing

PREPARE CUFF

Complete the following instructions to prepare the occlusive cuff:

1. Attach 15-gauge blunt tip needle to 30 cc syringe.
2. Fill syringe with approximately 10 cc of filling solution.
3. Hold air-filled cuff with one hand and squeeze it until it is deflated.
4. Insert needle into end of cuff tubing.
5. Aspirate any air left in cuff until you feel a slight resistance on the plunger. (**Figure 4-4a**)
6. Fill the cuff with 1 cc to 5 cc of recommended filling solution, depending on cuff size. (**Figure 4-4b**)

CAUTION: Do not over fill the cuff. (Figures 4-4c)
Excessive fluid can stretch cuff material.

Note: The amount of fluid that is needed to fill cuff will vary depending on cuff size - larger cuffs require more fluid than smaller cuffs.

7. Place syringe onto Mayo stand and hold both ends of cuff. Collect all small air bubbles into one large air bubble.
8. Roll end of cuff with your thumb to squeeze large air bubble into tubing adapter. (**Figure 4-4d**)

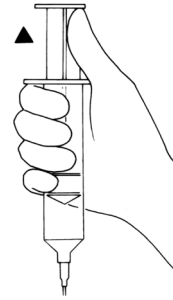

Figure 4-4a. Aspirate Air

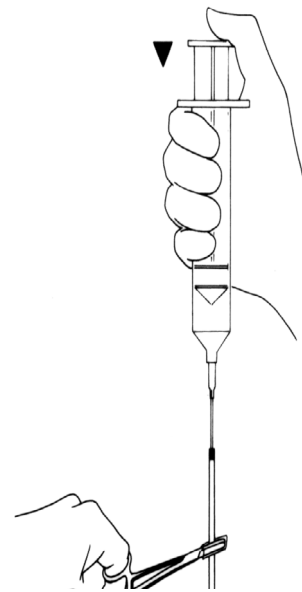

Figure 4-4b. Insert Needle Into Tube

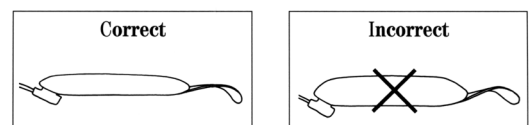

Figure 4-4c. Do Not Overfill Cuff

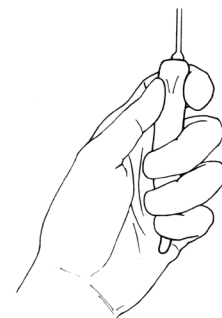

Figure 4-4d. Roll End of Cuff

SURGICAL PREPARATION (CONTINUED)

9. Hold syringe upright again (needle pointing down and plunger pointing up). Maintain pressure on cuff while pulling back on plunger to first aspirate remaining air bubble from cuff and then fluid.
10. If air remains in either cuff or tubing, repeat above steps.
11. With the air and fluid removed and cuff completely empty, use two tubing-shod mosquito hemostats to double-clamp cuff tubing (one notch only) 3 cm below needle and again 3 cm below first hemostat. **(Figure 4-4e)**
12. For a cuff treated with Inhibizone Antibiotic Surface Treatment, place the cuff onto an empty sterile tray or kidney basin and cover with a sterile drape. Prior to implanting, the cuff should be inspected for entrapped air.
13. For a non Inhibizone treated cuff, submerge the cuff into a kidney basin of sterile normal saline until the surgeon is ready to implant the cuff.

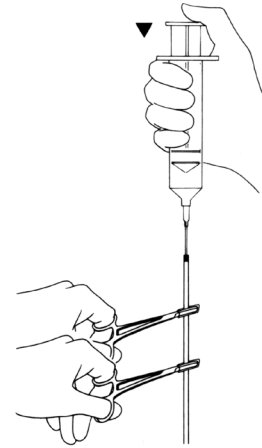

Figure 4-4e. Clamp Cuff

Caution: Soaking antibiotic impregnated devices in saline will cause the antibiotics to diffuse off the device into the solution. This will cause the solution to turn orange and will reduce the concentration of antibiotics on the device.

BULBOUS URETHRA CUFF PLACEMENT

SURGICAL PROCEDURES

There are several approaches to implantation of the AMS 800. It is important for the operating room staff to know which approach the surgeon intends to use because the approach will influence the position of the patient, instrumentation, selection of components, and the surgical sequence. The following brief descriptions give a general idea of the approaches.

BULBOUS URETHRA CUFF PLACEMENT - PERINEAL APPROACH

Complete the following steps to place the cuff at the bulbous urethra:

1. Place a Foley catheter or a 20Fr sound into urethra to help identify it during dissection.
2. Make a midline perineal incision and bluntly dissect bulbocavernosus muscle from around the bulbous urethra.

(Figure 4-6)

Note: Use blunt dissection.

3. Place cuff sizer (or Penrose drain) around urethra where cuff is to be implanted. It should fit snugly without constricting urethra.

(Figure 4-7)

Note: If catheter or sound is in urethra, remove it before measuring the urethra.

Note: Do not stretch cuff sizer before use.

Note: Surgeon should use his or her judgment in choosing an appropriate cuff size; the measuring tape only provides approximate measurement of bulbous urethra circumference. The inside circumference of cuff is somewhat smaller than the outside circumference of cuff.

4. Select cuff size that corresponds to measured length.

Note: A cuff length of 4.0 cm or 4.5 cm is typically required for bulbous urethra placement.

Note: Cuff length is outside circumference of cuff when it encircles urethra.

5. Prepare cuff for implantation.
6. Position cuff at the implant site with the mesh backing toward the outside and the inflatable side toward the urethra.

7. Pass prepared cuff, tab first, under urethra.

Note: Tubing should be on the pump side.

CAUTION: To avoid damage to the cuff, grasp the cuff tab with a tubing-shod hemostat.

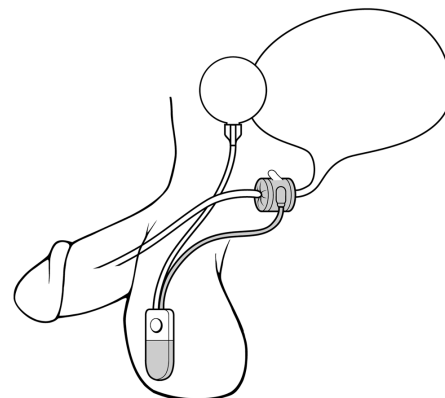

Figure 4-5. Bulbous Urethra Placement

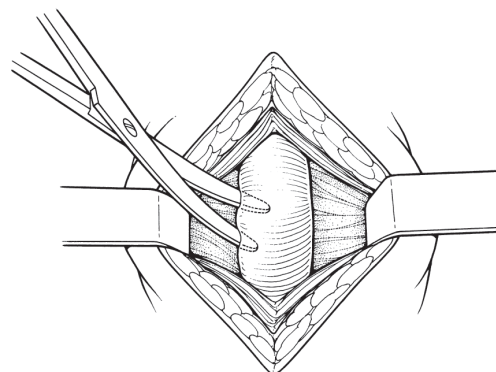

Figure 4-6. Dissect Bulbocavernosus Muscle

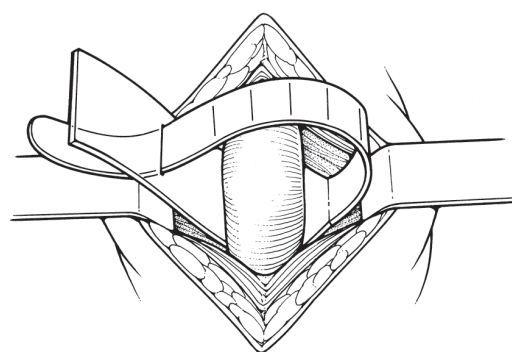

Figure 4-7. Measure Urethral Circumference

BULBOUS URETHRA CUFF PLACEMENT (CONTINUED)

8. Pass tubing through tab hole as follows:
 - Pass the end of the cuff tubing through the hole until the hemostat meets the hole. Clamp a second hemostat onto the cuff tubing on the opposite side of the hole, and then release the first hemostat, so air does not enter the cuff.
 - Pull the remainder of the tubing through the hole and close the cuff by pulling the tab over the tubing adapter (button). Ensure that the edges of the hole fit into the slot of the adapter.
 - Rotate the cuff so the adapter is lateral to the urethral midline and position the tubing to avoid contact with the cuff.

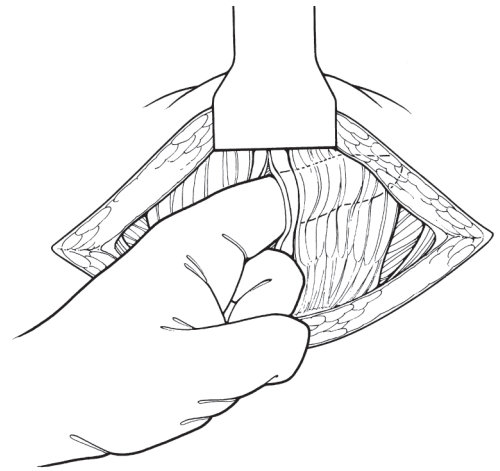

Figure 4-8. Separate Linea Alba

Implant Pressure Regulating Balloon

9. Select appropriate pressure-regulating balloon.
10. Make a suprapubic incision, divide rectus fascia transversely, and use a spreading motion to separate the linea alba to reach prevesical space. (Figure 4-8)
11. Use blunt dissection to create a space for balloon.
12. Position the balloon in prevesical space.
13. Flush balloon tubing end using 22-gauge needle on 10 cc syringe filled with filling solution.
14. Connect 15-gauge needle on 30 cc syringe filled with filling solution to balloon and unclamp tubing.
15. Fill the balloon with 22 cc of the chosen filling solution.

Note: Larger cuff sizes may require more filling solution. Refer to step 17 for Cuff Pressurization Option.

16. Clamp (one notch only) the tubing approximately 3 cm from the end with a tubing-shod hemostat. (Figure 4-9)

CAUTION: Do not advance the hemostat's ratchet more than one notch. Excessive pressure will permanently damage tubing.

17. Cuff Pressurization Option: Larger cuff sizes may require more filling solution, which can be provided by pressurizing the cuff as follows:
 - Flush balloon and cuff tubing.
 - Make temporary connection with a suture-tied connector between balloon and cuff.
 - Unclamp; wait one minute; then reclamp (one notch only).
 - Disconnect balloon and cuff.
 - Flush balloon tubing, unclamp and aspirate filling solution.
 - Refill with 20 cc of filling solution and clamp.

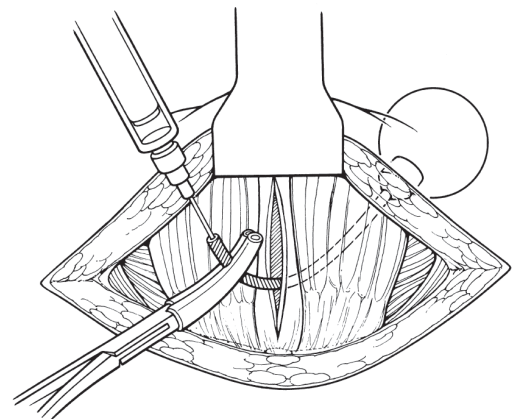

Figure 4-9. Fill PRB and Clamp Tubing

BULBOUS URETHRA CUFF PLACEMENT (CONTINUED)

Implant Pump

18. Use blunt dissection to create a dependent subdartos pouch in the scrotum. (**Figure 4-10**)

Note: Control pump should be placed on same side of the patient as the pressure-regulating balloon.

19. Place pump into scrotal pouch with deactivation button facing outward so that it is palpable. (**Figure 4-11**)

20. Route the tubing to abdominal incision.

Note: The pump tubing should be above rectus muscle and fascia in abdominal incision.

Connect Tubing

Follow the instructions given in the section on connecting the tubing. Check the connection by activating the system (closing/opening the cuff).

Deactivate

The device system must be left in the deactivated mode for four to six weeks following implantation. Deactivate the system by following the instructions given in the section on “Deactivating the System”.

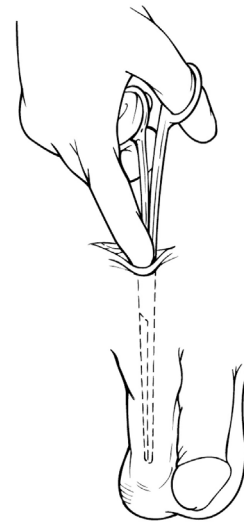

Figure 4-10. Create Pouch

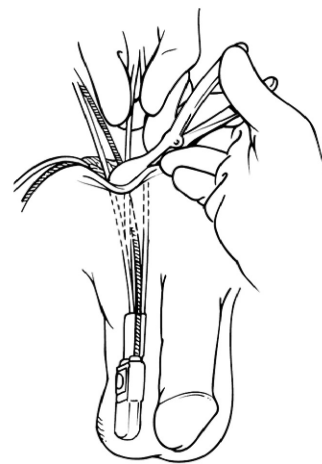

Figure 4-11. Place Pump Into Pouch

BULBOUS URETHRA CUFF PLACEMENT (CONTINUED)

BULBOUS URETHRA CUFF PLACEMENT - TRANSVERSE SCROTAL APPROACH

Complete the following steps to place the device through a scrotal incision:

1. Place the patient supine with his legs gently abducted on arm boards or other spreaders. Knees and hips are not flexed. This avoids placing the urethra on a stretch as occurs in the lithotomy position. **(Figure 4-12)** Place a urethral catheter to drain the bladder to avoid injury during placement of the pressure regulating balloon.
2. Make an upper transverse scrotal incision and deepen it through the subcutaneous tissue. Move the incision up onto the penis and stabilize with a retractor and blunt hooks at 1, 3, 5, 7, 9 and 11 o'clock. These stay hooks secure the scrotal incision onto the penis and help prevent unnecessary dissection in the scrotum. The scrotal incision allows excellent access to the proximal bulbar urethra and retropubic and dartos spaces, and leaves the bulbocavernosus muscle intact. **(Figure 4-13)**
3. Expose the tunica albuginea of both corpora cavernosa sharply. Pass the Metzenbaum scissors proximally along the ventral surface of the tunica to the proximal corpora. **(Figure 4-14)**
4. When deep exposure of the proximal corpora is secured, a Deaver retractor is placed on the side of the urethra for caudal retraction. **(Figure 4-15)**



Figure 4-12.

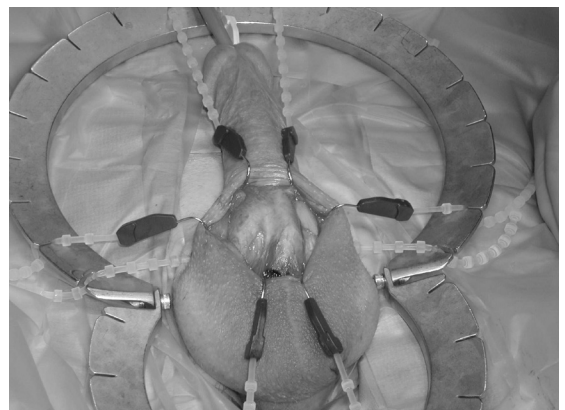

Figure 4-13.

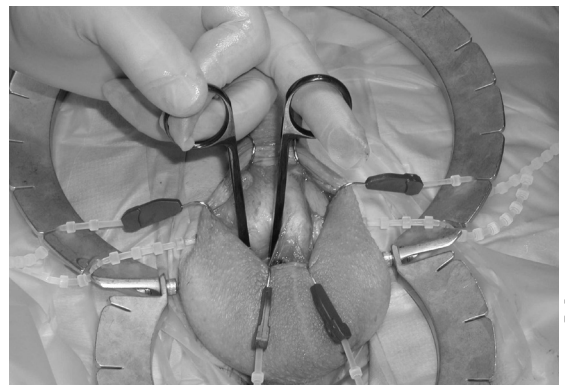

Figure 4-14.

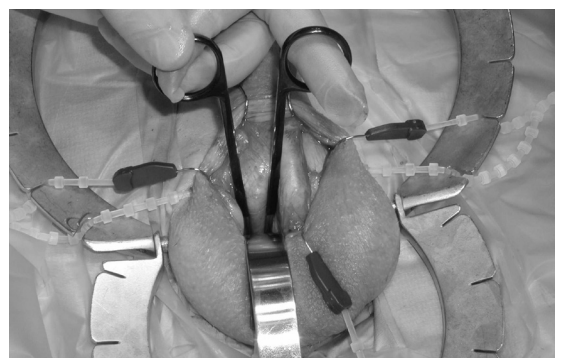

Figure 4-15.

BULBOUS URETHRA CUFF PLACEMENT (CONTINUED)

5. This is repeated on the contralateral side exposing the scrotal septum. (**Figure 4-16**)

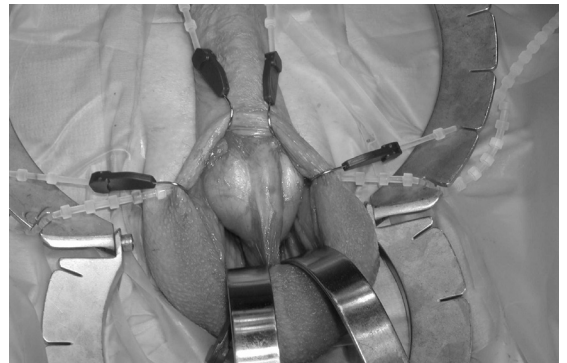

Figure 4-16.

6. The scrotal septum is then sharply dissected off the bulbar urethra. (**Figure 4-17**)

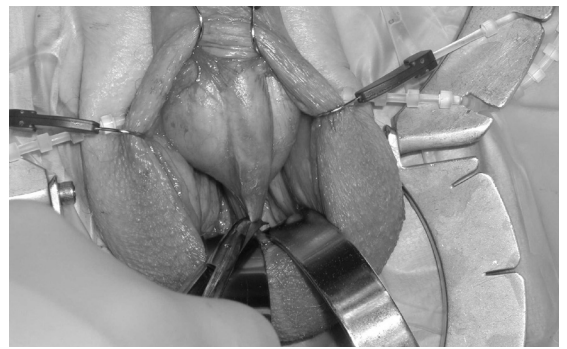

Figure 4-17.

7. By sharply dissecting webs of Buck's fascia binding the diverging corpora cavernosum to the corpora spongiosum, mobilization of the urethra can readily be achieved. (**Figure 4-18**)

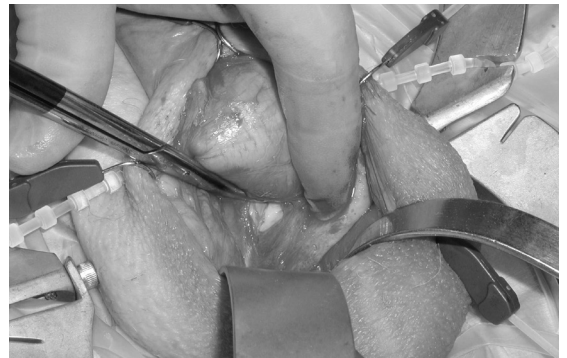

Figure 4-18.

8. Because the patient is in the supine position, the urethra is mobile and a right angle clamp can be used to conduct the posterior dissection of the urethra almost under direct vision. The right angle clamp is spread to create sufficient space for the placement of the occlusive cuff. (**Figure 4-19**)

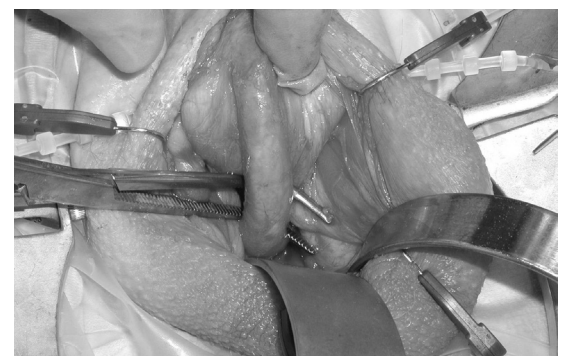

Figure 4-19.

BULBOUS URETHRA CUFF PLACEMENT (CONTINUED)

9. Measure the urethra and place the proper size occlusive cuff around the circumference.

(Figure 4-20)

Implant Pressure Regulating Balloon

10. There are two ways to place the pressure-regulating balloon (PRB).

- a. Empty the bladder, remove the Scott retractor and displace the scrotal incision to the side of the penis. Place the PRB in the retro-pubic space by locating the inguinal ring and piercing the transversalis fascia. After PRB implantation, narrow the opening by placing an absorbable suture.

(Figure 4-21)



Figure 4-20.

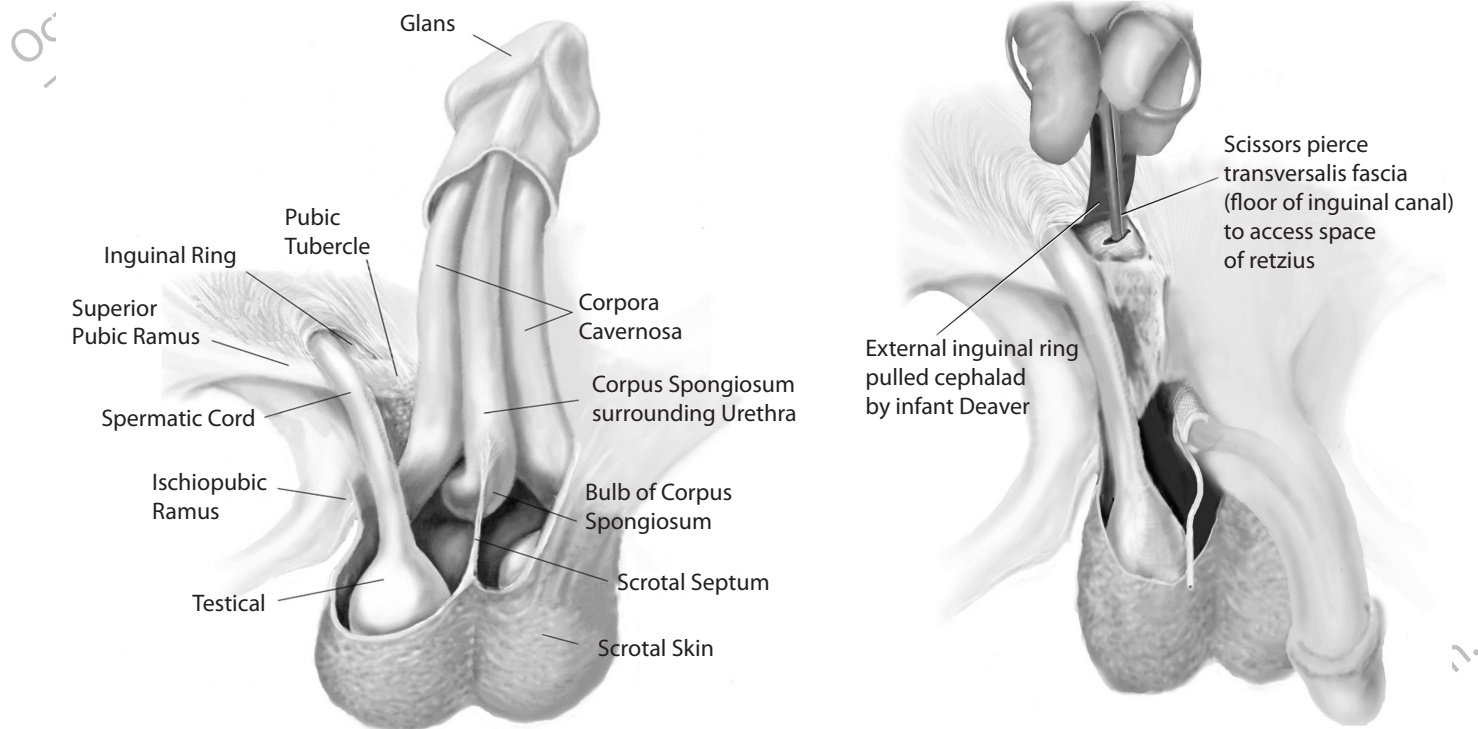

Figure 4-21.

- b. Displace the scrotal incision over the inguinal area and locate the inguinal ring. Use finger dissection to develop a pouch beneath the rectus but anterior to the transversalis fascia (cephalad to the inguinal ring). This avoids the necessity of piercing the fascia in patients with scarred retroperitoneum from radiation or radial surgery. After PRB implantation, narrow the opening by placing an absorbable suture.

BULBOUS URETHRA CUFF PLACEMENT (CONTINUED)

Implant Pump

11. Evaluate the inferior aspect of the scrotal incision and develop a space underneath the scrotal skin and dartos muscle to serve as a pouch for the pump. Begin the development of the tunnel about 2 cm from the skin edge in order to facilitate eventual tubing and connector concealment. Loosely tie a purse string suture around the opening of the tunnel to secure the pump position. (Figure 4-22)



Figure 4-22.

Connect Tubing

Follow the instructions given in the section on connecting the tubing. Check the connection by activating the system (closing/opening the cuff).

Deactivate

The device system must be left in the deactivated mode for four to six weeks following implantation. Deactivate the system by following the instructions given in the section on “Deactivating the System”.

BULBOUS URETHRA CUFF PLACEMENT (CONTINUED)

ATTACHING A SECOND CUFF TO THE SYSTEM

Clinical literature reports that a small percentage of patients with severe stress incontinence may continue to report some degree of incontinence even after the placement of an artificial urinary sphincter. In such cases, a second cuff may be implanted in males around the bulbous urethra.

The second cuff is connected to the device system through the use of a 3-way connector included in the Accessory Kit. Once the device is ready to be cycled, it will take about twice as long for both cuffs to fill as it does for one cuff to fill from a single balloon.

If the patient is experiencing incontinence secondary to urethral atrophy at the site of the first cuff, the first cuff may also require replacement.

Table 1-1. Double Cuff Combinations

Cuff Sizes	3.5	4.0	4.5	5.0	5.5	6.0	6.5	7.0	7.5	8.0	9.0	10	11
3.5													
4.0													
4.5													
5.0													
5.5													
6.0													
6.5													
7.0													
7.5													
8.0													
9.0													
10													
11													



Indicates cuff combinations that may be used.

BULBOUS URETHRA CUFF PLACEMENT (CONTINUED)

Components and Accessories

- 2 cuffs
- 1 pressure regulating balloon
- 1 control pump
- 1 Accessory Kit
- Tubing passers, Quick Connect Tool (when necessary)

Choose the Correct Size of Cuff

Follow the usual instructions as discussed earlier for cuff selection by properly measuring the bulbous urethra with the Cuff Sizer.

Fill the Components

More filling solution must be added to the system to account for the additional cuff. A single cuff system calls for filling the system with 22 cc, aspirating the pressure regulating balloon and refilling it with 20 cc. To account for the second cuff, the system should be filled with 24 cc, the pressure regulating balloon aspirated, and refilled with 20 cc. When pressurizing the cuffs, wait 60 seconds for both cuffs to pressurize.

Place a Second Cuff

First, deactivate the artificial urinary sphincter and insert a Foley catheter to facilitate urethral palpation. Follow the steps discussed earlier in this Manual for urethral measurement and cuff selection. When placing the second cuff either proximal or distal to the first cuff, allow a 1 to 2 cm gap between the two cuffs to prevent them from rubbing against each other and to maintain vascularization.

If Original Cuff is being replaced

With both new cuffs in place and clamped, flush the tubing and secure the 3-way connector to the two cuff ends with 3-0 nonabsorbable polypropylene suture. Flush the 3-way connector. Connect the pressure regulating balloon, which has previously been filled with 24 cc filling solution. Remove the clamps from the cuff and balloon tubing. Allow 60 seconds for the cuffs to pressurize, and then re-clamp each cuff tubing below the 3-way connector.

Disconnect the balloon, aspirate the fluid from the balloon and refill it with 20 cc. When ready to connect the pump tubing, first flush the 3-way connector to remove air and particulate matter. Follow the previously described steps for connecting the tubing and tying with suture.

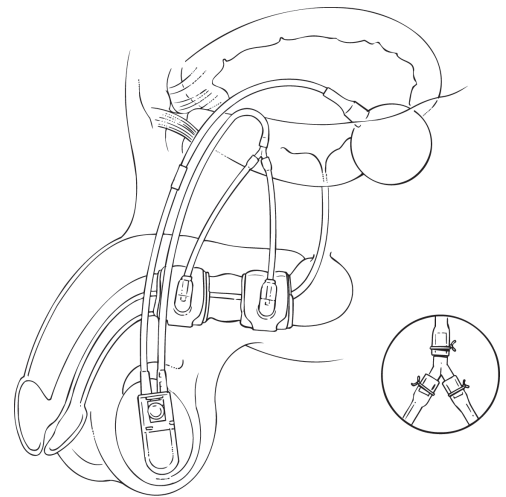

Figure 4-23.

BULBOUS URETHRA CUFF PLACEMENT (CONTINUED)

If Original Cuff is Preserved

Find the white/clear tubing leading from the existing cuff to the pump. Clamp the tubing on each side of the current connector. Cut the connector. With the new cuff in place, trim the tubing to the desired length, and flush the end. Connect a syringe filled with 10 cc of filling solution and a 15-gauge blunt tip needle attached to the new cuff tubing. Remove the clamp, and add 1-2cc (depending on the size of the cuff) of filling solution to the new cuff. Re-clamp the tubing and remove the syringe. Flush the tubing, attach the 3-way connector and pump tubing, and suture tie the connector to the pump tubing.

Connect Tubing

Follow the usual instructions for connecting the tubing when using the straight and right-angle connectors. The 3-way connector is suture tied to the cuffs and pump tubing. You may secure the 3-way connector to fascia or subcutaneous tissue to keep it stationary.

Deactivate

The device system must be left in the deactivated mode for four to six weeks following implantation. Deactivate the system by following the instructions given in the section on “Deactivating the System”.

BLADDER-NECK CUFF PLACEMENT

BLADDER-NECK CUFF PLACEMENT

Place a catheter into urethra to drain bladder and to help identify during dissection.

1. To begin the procedure, make a suprapubic incision and dissect around the bladder neck. (**Figure 4-24**)
2. To determine the size of cuff that is needed, measure the circumference of the urethra at the bladder neck with the Cuff Sizer. Place the Cuff Sizer around the urethra at the site where the cuff is to be implanted. It has to fit snugly without constricting the urethra. If a catheter has been placed in the urethra, it must be removed before measuring the bladder neck. (**Figure 4-25**)
3. Select the cuff size that corresponds to the measured length.
4. Prepare the selected cuff for implantation (see instructions for Preparing the Occlusive Cuff).
5. To implant the prepared cuff, pass the cuff, tab first, under the bladder neck. To avoid damage to the cuff, grasp it with a silicone-shod hemostat and grab the tab and pull.

Implant Pressure Regulating Balloon

6. Select the appropriate pressure-regulating balloon.
7. Use blunt dissection to create a space for the balloon in the prevesical space. Position the balloon in the prevesical space. (**Figure 4-26**)
8. Fill the balloon with 22cc of the appropriate filling solution and clamp the tubing 3cm from the end with a silicone-shod hemostat (one notch only).
9. Route the balloon tubing and the cuff tubing to the inguinal area. (**Figure 4-27**)
10. To pressurize the cuff, the cuff tubing and the balloon tubing are temporarily connected using a straight suture-tie connector. If a catheter has been placed in the urethra, make sure it is removed before pressurization. Remove the tubing clamps and wait 30 seconds for the cuff to pressurize.
11. Clamp the cuff tubing and the balloon tubing approximately 3cm from the end with silicone-shod hemostats and remove the connector.
12. Insert a syringe with a 15-gauge needle into the balloon tubing, remove the hemostat, and aspirate all of the remaining fluid from the balloon. Refill it with 20cc of filling solution, clamp the tubing with a silicone-shod hemostat, and remove the syringe.

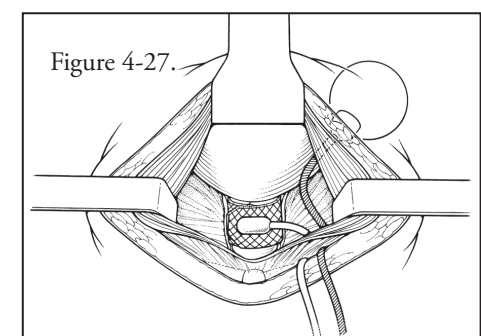
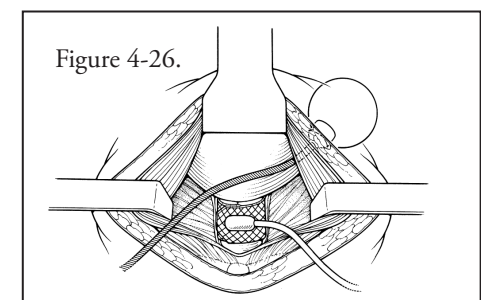
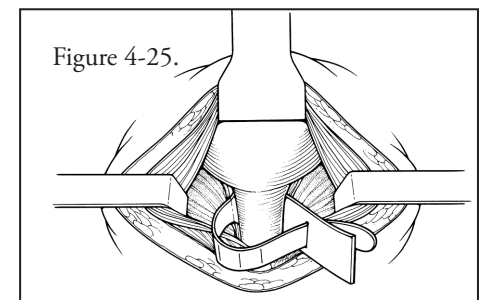
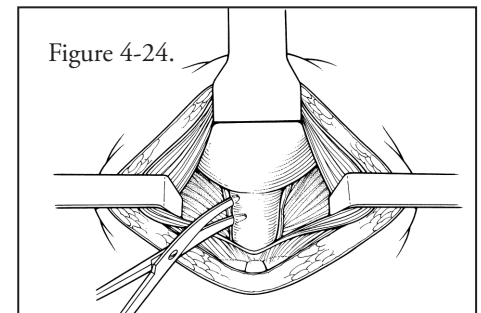
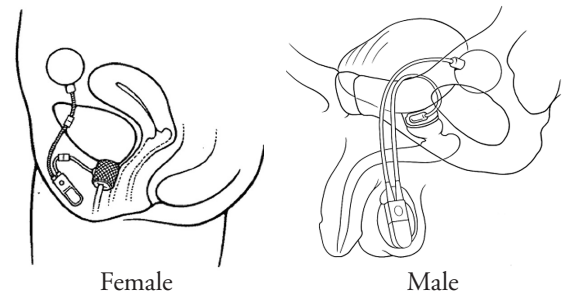

BLADDER-NECK CUFF PLACEMENT (CONTINUED)

Implant Pump

13. To implant the control pump in the scrotum or labium, use blunt dissection to create a dependent subdartos pouch. The control pump should be placed on the same side where the pressure-regulating balloon was placed. **(Figure 4-28)**
14. Place the pump in the pouch, with the deactivation button facing outward so that it is palpable. Route the pump tubing to the inguinal area. **(Figure 4-29)**

Connect Tubing

Follow the instructions given in the section on connecting the tubing. Check the connection by activating the system (closing/opening the cuff).

Deactivate

The device system must be left in the deactivated mode for four to six weeks following implantation. Deactivate the system by following the instructions given in the section on “Deactivating the System”.

Transvaginal Approach

Some physicians prefer to implant the cuff in their female patients through a transvaginal incision. To begin, place the patient in a standard lithotomy position, prep, and drape. Make an inverted “U” incision in the anterior wall of the vagina. Start blunt dissection around the bladder neck. When dissection is complete, measure the circumference of the bladder neck with the Cuff Sizer to determine the size of cuff that is needed. If a catheter has been placed in the urethra, it must be removed before measuring the bladder neck. Select and prepare the appropriate size cuff and implant it around the bladder neck. If the cuff is being implanted trans-vaginally, a second small suprapubic incision must be made to place the pressure regulating balloon and control pump.

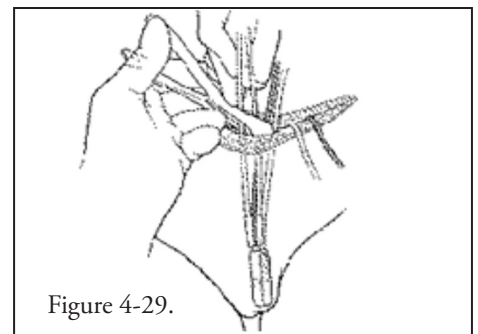
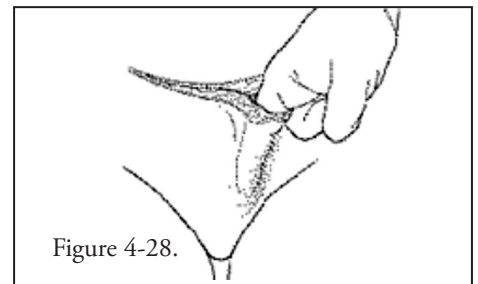

CONNECT TUBING

CONNECT TUBING

AMS Suture-Tie Connectors or AMS Quick Connect Sutureless Window Connectors are used to connect the tubing. In most cases, use the straight connectors. Right angle connectors should always be used when the tubing makes a sharp curve at the point of connection.

CAUTION: AMS Quick Connect Sutureless Window Connectors should not be used in revision procedures involving previously implanted component tubing. Changes in the tubing over time may reduce the fixation performance of the Quick Connect Sutureless Window Connectors. The Quick Connect system may be used when all previously implanted components are removed and replaced with new components.

Using AMS Quick Connect Sutureless Window Connectors

1. Using clean, well-cutting scissors, trim tubing lengths squarely to fit patient's anatomy. **(Figure 4-30)**
2. Slide collet ring onto tubing, making sure collet ring teeth face toward tubing end. **(Figure 4-31)**
3. Use 22-gauge needle and 10 cc syringe filled with filling solution to flush connector and tubing **(Figure 4-32)** to remove particulate matter and air.
4. Insert tubing end into connector. **(Figure 4-33)**
 - Firmly push one side of tubing to middle wall of connector.
 - Check placement through connector window.
 - Flush both connector and tubing before final connection.
5. Insert other tubing end into connector. **(Figure 4-33)**
 - Firmly push one side of tubing to middle wall of connector.
 - Check that both tubing ends touch middle.
6. Place straight connector ends into assembly tool jaws.

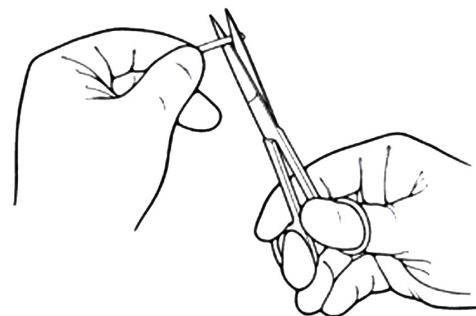

Figure 4-30. Trim Tubing

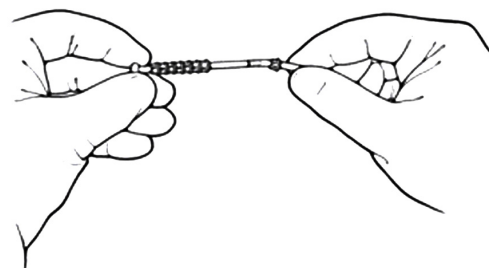

Figure 4-31. Slide on Collet

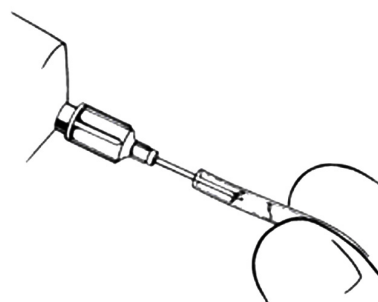

Figure 4-32. Flush Tubing and Connector

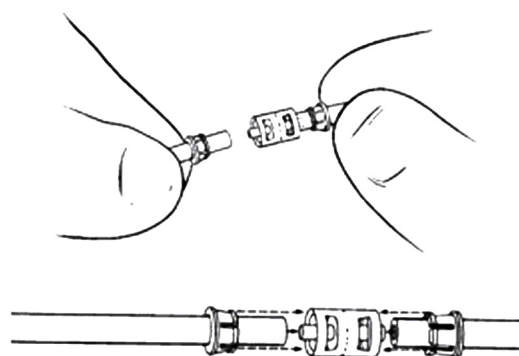

Figure 4-33. Insert Tubing Into Connector

CONNECT TUBING (CONTINUED)

7. Squeeze tool handles until closure stop touches opposite handle. (Figure 4-34)

CAUTION: Check tubing before you close assembly tool. Do not trap tubing between assembly tool jaw and connector. Tubing must exit straight from ends of connector, through slots in assembly tool.

CAUTION: After using assembly tool, tubing should bulge through connector window. This indicates that tubing is firmly against middle of connector wall.

8. If using right angle connector:
 - Use tool twice, once on each end. (Figure 4-35)

Note: Squeeze tool handles until closure stops touches opposite handle.

9. When using a 3-way connector, the assembly tool must be used 3 times - once on each end of the connector. The assembly tool must be engaged from the side of each connector end. Advance the tubing into each connector end until the tubing touches the inner connector wall as seen through the connector window. (Figure 4-36)

CAUTION: The long branch of the 3-way connector must be connected to the control pump.

10. After all connections have been made, cycle the device to confirm function, and deactivate the device (see instructions).

Using AMS Suture-Tie Connectors

All connections using AMS Suture-Tie Connectors are tied with 3-0 nonabsorbable polypropylene.

1. Using clean, well-cutting scissors, trim tubing lengths squarely to fit patient's anatomy.
2. Use a 22-gauge blunt tip needle and 10cc syringe to flush tubing ends with filling solution to remove particulate matter and air before connecting.
3. Push connector ends over tubing so that they meet at connector's center hub; use 22-gauge blunt tip needle to flush connector before completing connection.

Note: Be certain that the tubing ends are touching the center hub.

4. Use a double-throw overhand surgeon's knot followed by two single throws to attach the tubing to the connector.

Note: Suture should crimp, but not cut the tubing.

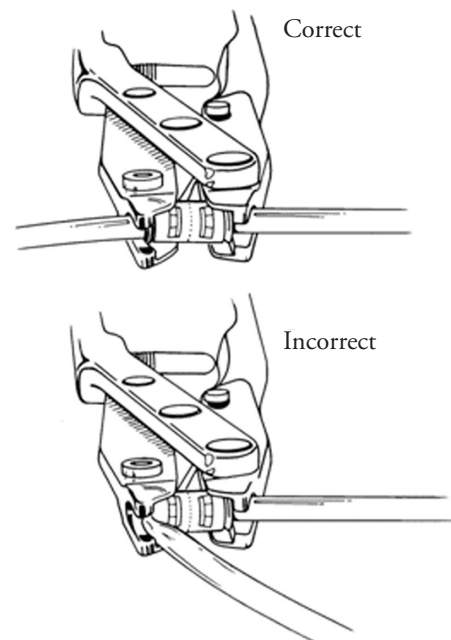

Figure 4-34. Closing Assembly Tool

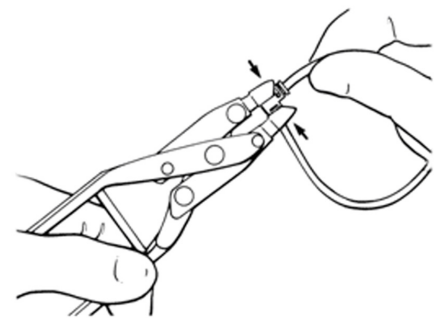

Figure 4-35. Using a right angle connector

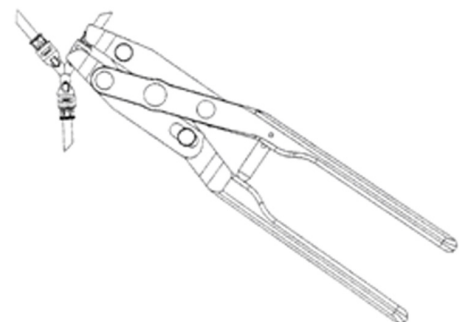

Figure 4-36. Quick Connect Assembly Tool (Approach from the side of 3-way connector)

CONNECT TUBING (CONTINUED)

5. Pass the suture to the opposite side of the connector, and use the same tying technique. (**Figure 4-37**)
6. After all connections have been made, cycle the device to confirm function, and deactivate the device (see instructions).



Figure 4-37. Suture-Tie Connector

DEACTIVATION KIT

The Deactivation Kit is useful during revision surgical procedures. The following example describes explanting only the cuff and preserving the other components.

When the cuff needs to be explanted due to erosion, first clamp the tubing with jaw-protected hemostats at both sides of the connector. Then, cut the tubing and explant the cuff. Unless infected, the pressure-regulating balloon and control pump may be left in the body with the tube plugs inserted into the tubing ends while the tissue around the urethra heals after the cuff is explanted.

By inserting a tubing plug into the end of the control pump tubing (with clear, reinforcement filament) the surgeon can protect the filling solution from contamination by blood or other materials during deactivation.

1. Flush the inside of the tubing end with a 22 gauge blunt needle, then insert a tubing plug from the Deactivation Kit.
2. Suture-tie the tube plug with 3-0 non-absorbable suture. When tying, use one double-throw, overhand surgical knot followed by at least two single throw knots to attach the connector to the tubing. The suture should clamp the tubing, but not so tight that it cuts the tubing.
3. The Tubing Plug connected to the control pump tubing is placed in the same superficial location as the original connectors and the incision is closed.
4. After healing takes place, when the new cuff is inserted, clamp the tubing beneath the plug with a tubing-shod clamp. Remove plug. Make sure the ends of the tubing have been cut squarely. Using a 22 gauge needle and a 10 cc syringe, flush end of tube with system fluid. Reconnect to component using a suture-tie connector. No additional filling or priming is necessary as all the original fluid is maintained within the system.

DEVICE OPERATION

DEACTIVATE CUFF

To deactivate the device, complete the following instructions:

1. Squeeze and release the pump bulb several times to remove all fluid from cuff. (**Figure 4-38**)

Note: The cuff will be empty when the pump remains flat.

2. Allow pump bulb to partially refill (approximately 30 seconds to one minute).

Note: It is recommended that time needed to fill pump or number of pumps needed to empty pump be recorded. This information is helpful postoperatively.

3. When slight indentation in pump bulb is felt, press the deactivation button (**Figure 4-39**).

Note: It is important to leave a slight indentation in the pump bulb to ensure there is enough fluid in the pump to activate the device later. The urethra must be open, but the pump bulb should not be totally flattened.

Note: You will always feel the deactivation button, even when the device is deactivated. (This is not the type of button that bulges into the base).

4. After you press deactivation button, the pump bulb may feel more firm than usual.

Note: The indentation in the pump bulb will remain partially filled until activated. When the device is deactivated, the cuff will not be inflated (urethra not closed) and your patient will be incontinent. No fluid will move into cuff or pump when it's deactivated.

ACTIVATE (REACTIVATE) CUFF: NORMAL METHOD

To activate (reactivate) the device, complete the following instructions:

5. Push deactivation button a few times to loosen the poppet. (**Figure 4-40**). Then give the pump bulb a quick, forceful squeeze.

*Note: This will move deactivation poppet back to activated position. After device is activated, pump will fill first and then cuff will refill (**Figure 4-41**). It will take a few minutes for device to refill and for cuff to close off urethra or bladder neck. When system is activated, the pump may become less firm.*

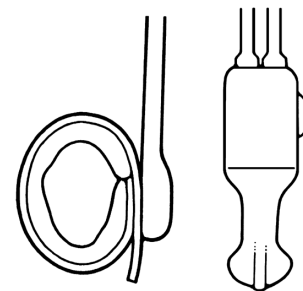

Figure 4-38. Squeeze and Release Pump Bulb

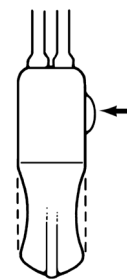

Figure 4-39. Press Deactivation Button When Slight Indention Felt

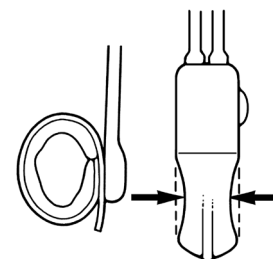

Figure 4-40. Activate (Reactivate) the System (get out of deactivation status)

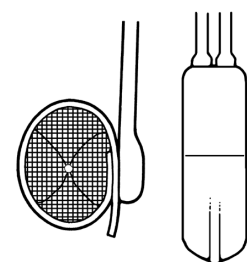

Figure 4-41. Cuff and Pump Refilled

DEVICE OPERATION (CONTINUED)

Note: If you have difficulty activating device, there may not be enough fluid remaining in pump to push deactivation button to its activated position. Use an optional method described below if this happens.

ACTIVATE (REACTIVATE) CUFF: OPTIONAL METHODS

If the normal activation method does not work, use one of the following optional methods.

Side Squeeze Method

1. Squeeze sides of control pump adjacent to deactivation button to allow fluid to fill the pump bulb. **(Figure 4-42)**

Note: It may take several minutes for the pump to refill. When enough fluid has returned to the pump bulb, give it a quick, forceful squeeze in order to reactivate the system.

Cotton Swab Method

1. Feel control pump to locate deactivation button.
2. Take a cotton tip swab and apply pressure to area directly behind deactivation button. **(Figure 4-43)**

Note: This should unseat the poppet and allow fluid to fill pump and then cuff.

Valve Block Bending Method

1. Feel the control pump, locate the deactivation button, and place your index finger above it (at tubing side). **(Figure 4-44)**
2. Place tip of your thumb below deactivation button on the opposite side.
3. Place index finger of your other hand on firm portion of pump (valve block portion) in front of deactivation button (toward the pump bulb).
4. Firmly bend pump end down to activate, by using thumbs as a fulcrum.
5. Release after bending.
6. Squeeze and release pump bulb several times to transfer fluid.

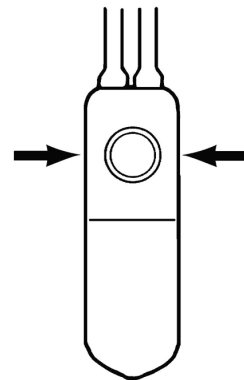

Figure 4-42. Side Squeeze Method

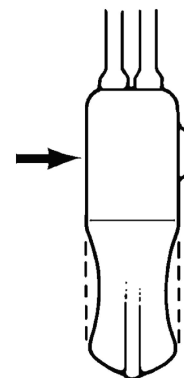

Figure 4-43. Cotton Swab Method

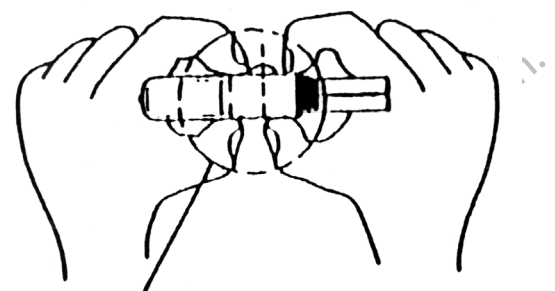

Figure 4-44. Fulcrum Method

POST OPERATIVE CARE

Some surgeons use a prophylactic antibiotic prior to surgery and intravenous antibiotics immediately post-operatively. Most choose to send their implanted patients home with a five to ten day course of antibiotics. The following paragraphs provide additional details on postoperative care.

IMMEDIATELY POSTOPERATIVE

After the surgery, deactivate the cuff and introduce a catheter into the urethra prior to closing. The length of time the catheter is left in place is at the discretion of the physician.

After 24 hours, the nursing staff may place ice packs in the region of the pump to reduce postoperative edema. At the discretion of the implanting physician antibiotics may be prescribed. The patient should be advised on the use of absorbent pads or condom catheters, until the device is activated four to six weeks after the surgery. The patient should be advised to avoid undue compression of the cuff area.

AFTER RELEASE FROM HOSPITAL

The patient is usually discharged within one to four days after surgery. After leaving the hospital, the patient should take antibiotics as prescribed by the physician.

The patient must return to the physician's office to activate the device prior to use of the AMS 800 Urinary Control System. The device is normally activated four to six weeks postoperatively. At that time, instruct the patient that it is possible to begin using the prosthesis to urinate.

Activating the device may be difficult if deactivation occurred when the pump bulb was deflated. If unable to cycle the prosthesis, squeezing the sides of the control pump adjacent to the deactivation button will allow fluid to fill the pump bulb and then the pump can be cycled normally. Refer to the activation/deactivation instructions.

The patient may experience some mild discomfort the first few times the prosthesis is being used. To determine that the patient is ready to use the device, check the incision site to be sure that it has healed properly.

There should be no redness, swelling, or drainage. Any of these things may indicate that an infection is present and the infection should be treated appropriately. Ask the patient about tenderness and/or discomfort when cycling the device.

The physician may want to observe the patient for up to an hour in the office to determine if sufficient continence is achieved with the device activated.

Provide patient education with regard to the operation. Patients should carry a permanent patient ID card to inform others of the device in case of emergency and **to prevent catheterization without device deactivation (which could damage the urethra or the device).**

EVALUATING LONG-TERM FUNCTION AND PLACEMENT

After the postoperative healing period, the surgeon should continue to have contact with the patient at least on an annual basis to evaluate the function of the device. During the annual evaluation, the surgeon should ask the patient about how the device is functioning and if he/she has noticed any changes in the function.

If the patient is having mechanical difficulty with the device, or there is infection or erosion present, revision or removal surgery may be necessary. In the event of a revision surgery, follow the same preparation and implantation techniques outlined elsewhere in this manual. Suture tie connectors must be used in any revision surgery where the total device is not explanted.

DOCUMENTATION

COMPLETING THE PATIENT INFORMATION FORM

American Medical Systems requires that a Patient Information Form be completed and returned for each implantation procedure. This is necessary to comply with the AMS Limited Warranty Policy and for the patient to receive an ID card.

The top portion of the form concerns the patient and the procedure. The primary etiology should be specified in detail, and the component information—cuff size, balloon pressure, and serial/lot numbers—should be as complete as possible, using self-adhesive labels included within the packaging.

Promptly return the first copy of the Patient Information Form to American Medical Systems.

Retain the remaining copies for the files of the hospital, surgeon, or patient (if needed). Complete the Return Goods Form on the last page of the Patient Information Form if components were explanted.

INVENTORY RETURNS AND REPLACEMENT INFORMATION

A Patient Information Form (PIF) must be filled out and filed with American Medical Systems at the time of implant to activate the product warranty. Before returning any components, whether explanted or unused (sterile or nonsterile), customers must fill out the Return Goods Form located on the last page of the Patient Information Form.

Follow all of the instructions on the form carefully, and be sure that the components have been thoroughly cleaned before returning them to American Medical Systems. Request an AMS Product Return Kit from the AMS Customer Service Department to return any explanted components to American Medical Systems.

In all cases, obtaining credit or percentage of credit for a returned component is subject to approval under the terms of the AMS Return Goods Policy and the AMS Limited Warranty Policy. For complete information regarding these policies, contact the AMS Customer Service Department.

Contact your local AMS Representative prior to returning any product.

DOCUMENT INFORMATION

This document is written for professional medical audiences. Contact American Medical Systems for lay publications.

American Medical Systems periodically updates product literature. If you have questions about the currency of this information, contact American Medical Systems.

TROUBLESHOOTING

Problem

What to Do

Total Device

The device fails to cycle

Check connections between components. If they are correct, change the entire device

Leak in any of the components

Check if there is a leak by pump manipulation or ultrasound. If there is a leak, replace all the components (because body fluid has entered into the system.)

Occlusive cuff

Too tight or too loose around the urethra.

Remove improperly-sized cuff. Remeasure with the urethra-cuff sizer and implant proper size.

Punctured or damaged

Remove and replace with new cuff

Pressure-Regulating Balloon

Punctured during filling

Remove and replace with new pressure-regulating balloon.

Control Pump

Difficulty activating (reactivating) the device

Squeeze and release the sides of the control pump adjacent to the deactivation button to allow fluid to fill the pump bulb. When enough fluid has returned to the pump bulb, give it a quick, forceful squeeze (see the activation section for other methods).

Остаряла версия. Да не се използва.
Zastaralá verze. Nepoužívat.
Forældet version. Må ikke anvendes.
Version überholt. Nicht verwenden.
Aegunud versioón. Ärge kasutage.
Παλιά έκδοση. Μην την χρησιμοποιείτε.
Outdated version. Do not use.
Versión obsoleta. No utilizar.
Zastarjela verzija. Nemojte upotrebljavati.
Úreilt útgáfa. Notið ekki.
Versione obsoleta. Non utilizzare.
Pasenusi versija. Neizmantot.
Elavult verzió. Ne használja!
Dit is een verouderde versie. Niet gebruiken.
Wersja przeterminowana. Nie używać.
Versão obsoleta. Não utilize.
Versiune expirată. A nu se utiliza.
Zastaraná verzia. Nepoužívať.
Vanhentunut versio. Älä käytä.
Föråldrad version. Använd ej.
Güncel olmayan sürüm. Kullanmayın.

Остаряла версия. Да не се използва.
Zastaralá verze. Nepoužívat.
Forældet version. Må ikke anvendes.
Version überholt. Nicht verwenden.
Aegunud versioón. Ärgе kasutage.
Παλιά έκδοση. Μην την χρησιμοποιείτε.
Outdated version. Do not use.
Versión obsoleta. No utilizar.
Zastarjela verzija. Nemojte upotrebljavati.
Úreilt útgáfa. Notið ekki.
Versione obsoleta. Non utilizzare.
Pasenusi versija. Neizmantoť.
Elavult verzió. Ne használja!
Dit is een verouderde versie. Niet gebruiken.
Wersja przeterminowana. Nie używać.
Versão obsoleta. Não utilize.
Versiune expirată. A nu se utiliza.
Zastaraná verzia. Nepoužívať.
Zastarela različica. Ne uporabite.
Vanhentunut versio. Älä käytä.
Föråldrad version. Använd ej.
Güncel olmayan sürüm. Kullanmayın.

Australian Sponsor Address

Boston Scientific (Australia) Pty Ltd
PO Box 332
BOTANY
NSW 1455
Australia
Free Phone 1800 676 133
Free Fax 1800 836 666

Brazil Local Contact

Para informações de contato da
Boston Scientific do Brasil Ltda,
por favor, acesse o link
www.bostonscientific.com/bra

Остаряла версия. Да не се използва.
Zastaralá verze. Nepoužívat.
Forældet version. Må ikke anvendes.
Version überholt. Nicht verwenden.
Version obsolete. Mην την χρησιμοποιείτε.
Outdated version. Do not use.
Version périmée. Ne pas utiliser.
Zastarjela verzija. Nemojte upotrebljavati.
Úreilt útgáfa. Notið ekki.
Versione obsoleta. Non utilizzare.
Pasenusi versija. Neizmanto.
Elavult verzió. Ne használja!
Dit is een verouderde versie. Niet gebruiken.
Wersja przeterminowana. Nie używać.
Versão obsoleta. Não utilize.
Versione expirată. Skal ikke brukes.
Zastaraná verzia. Nepoužívať.
Zastarela različica. Ne uporabite.
Vanhentunut versio. Älä käytä.
Föråldrad version. Använd ej.
Güncel olmayan sürüm. Kullanmayın.

Остаряла версия. Да не се използва.
Zastaralá verze. Nepoužívat.
Forældet version. Må ikke anvendes.
Version überholt. Ärge kasutage.
Αεγονυδ versioon. Μην την χρησιμοποιείτε.
Παλιά έκδοση. Μην την χρησιμοποιείτε.
Outdated version. Do not use.
Versión obsoleta. No utilizar.
Zastarjela verzija. Nemojte upotrebljavati.
Version périmée. Ne pas utiliser.
Zastarjela verzija. Nemojte upotrebljavati.
Úreilt útgáfa. Notið ekki.
Versione obsoleta. Non utilizzare.
Pasehujusi versija. Neizmantot.
Elavult versio. Ne használja!
Versiune expirată. Nu se utilizează.
Zastarana verzija. Nie używać.
Versiune expirată. Nu se utilizează.
Zastarana verzija. Nie używać.
Vanhentunut versio. Älä käytä.
Föråldrad version. Använd ej.
Güncel olmayan sürüm. Kullanmayın.

AMS™



American Medical Systems, Inc.
10700 Bren Road West
Minnetonka, MN 55343
U.S.A.
US toll-free: 1 800 328 3881
Tel: + 1 952 930 6000
Tel: + 31 20 593 8800

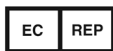

American Medical Systems
Europe B.V.
Haarlerbergweg 23 G
1101 CH Amsterdam Zuid-Oost
The Netherlands



©2016 Boston Scientific Corporation or its affiliates.
All rights reserved. All trademarks are the property
of the respective owners.

1002533 Rev B (2016-07)

