

REFERENCE GUIDE

**AUTOGEN™ CRT-D,
AUTOGEN™ X4 CRT-D,
DYNAGEN™ CRT-D,
DYNAGEN™ X4 CRT-D,
INOGEN™ CRT-D,
INOGEN™ X4 CRT-D,
ORIGEN™ CRT-D,
ORIGEN™ X4 CRT-D,
INCEPTA™ CRT-D,
ENERGEN™ CRT-D,
PUNCTUA™ CRT-D,
PUNCTUA™ NE CRT-D,
COGNIS™ 100-D CRT-D**

CARDIAC RESYNCHRONIZATION THERAPY
DEFIBRILLATOR

REF G172, G173, G175, G177, G179, G150, G151, G156, G158, G140,
G141, G146, G148, G050, G051, G056, G058, P162, P163, P165, P142,
P143, P052, P053, P106, P107, P108

Остаряла версия. Да не се използва.
Zastaralá verze. Nepoužívat.
Forældet version. Må ikke anvendes.
Version überholt. Nicht verwenden.
Aegunud versioón. Myn þyn Χρησιμοποιείτε.
Παλιά έκδοση. Μην την χρησιμοποιείτε.
Outdated version. Do not use.
Versión obsoleta. No utilizar.
Zastarjela verzija. Nemojte upotrebljavati.
Úreilt útgáfa. Notið ekki.
Versione obsoleta. Ne pas utiliser.
Novecojsi versija. Non utilizzare.
Pasenusi versija. Neizmantot.
Elavult verzió. Ne használja!
Dit is een verouderde versie. Niet gebruiken.
Wersja przeterminowana. Nie używać.
Versão obsoleta. Não utilize.
Versiune expirată. A nu se utiliza.
Zastaraná verzia. Nepoužívať.
Vanhentunut versio. Älä käytä.
Föråldrad version. Använd ej.
Güncel olmayan sürüm. Kullanmayın.

ABOUT THIS MANUAL

INTENDED AUDIENCE

This literature is intended for use by professionals trained or experienced in device implant and/or follow-up procedures.

These families of cardiac resynchronization therapy defibrillators (CRT-Ds) provide ventricular tachyarrhythmia therapy, Cardiac Resynchronization Therapy (CRT), bradycardia pacing, and a variety of diagnostic tools.

The Physician Technical Manual, used in conjunction with the ZOOMVIEW software, is intended to provide information most relevant for implanting the pulse generator. The Physician Technical Manual also contains information such as warnings/cautions, potential adverse events, mechanical specifications, longevity, hyperbaric therapy, and programming considerations. This Reference Guide provides further descriptions of programmable features and diagnostics.

For information about MRI scanning, refer to the ImageReady MR Conditional Defibrillation System MRI Technical Guide.

To view and download any of these documents, go to www.bostonscientific-elabeling.com.

This guide may contain reference information for model numbers that are not currently approved for sale in all geographies. For a complete list of model numbers approved in your geography, consult with your local sales representative. Some model numbers may contain fewer features; for those devices, disregard descriptions of the unavailable features. Descriptions found within this manual apply to all device tiers unless otherwise noted. References to names of non-quadrupolar devices also apply to the corresponding quadrupolar devices.

The screen illustrations used in this manual are intended to familiarize you with the general screen layout. The actual screens you see when interrogating or programming the pulse generator will vary based on the model and programmed parameters.

LATITUDE NXT is a remote monitoring system that provides pulse generator data for clinicians. All pulse generators described in this manual (except PUNCTUA NE) are designed to be LATITUDE NXT enabled; availability varies by region.

A complete list of programmable options is provided in the appendix ("Programmable Options" on page A-1). The actual values you see when interrogating or programming the pulse generator will vary based on the model and programmed parameters.

The text conventions discussed below are used throughout this manual.

PRM KEYS

The names of Programmer/Recorder/Monitor (PRM) keys appear in capital letters (e.g., PROGRAM, INTERROGATE).

1., 2., 3.

Numbered lists are used for instructions that should be followed in the order given.

•

Bulleted lists are used when the information is not sequential.

The following acronyms may be used in this manual:

A	Atrial
ABM	Autonomic Balance Monitor
AF	Atrial Fibrillation

AFib	Atrial Fibrillation
AFR	Atrial Flutter Response
AGC	Automatic Gain Control
AIVR	Accelerated Idioventricular Rhythm
AT	Atrial Tachycardia
ATP	Antitachycardia Pacing
ATR	Atrial Tachy Response
AV	Atrioventricular
BiV	Biventricular
BCL	Burst Cycle Length
BPEG	British Pacing and Electrophysiology Group
BTR	Brady Tachy Response
CPR	Cardiopulmonary Resuscitation
CRT	Cardiac Resynchronization Therapy
CRT-D	Cardiac Resynchronization Therapy Defibrillator
DFT	Defibrillation Threshold
EAS	Electronic Article Surveillance
ECG	Electrocardiogram
EF	Ejection Fraction
EGM	Electrogram
EMI	Electromagnetic Interference
EP	Electrophysiology; Electrophysiologic
HE	High Energy
HRV	Heart Rate Variability
IBP	Indications-Based Programming
IC	Industry Canada
ICD	Implantable Cardioverter Defibrillator
LRL	Lower Rate Limit
LV	Left Ventricular
LVAT	Left Ventricular Automatic Threshold
LVPP	Left Ventricular Protection Period
LVRP	Left Ventricular Refractory Period
MI	Myocardial Infarction
MICS	Medical Implant Communication Service
MPR	Maximum Pacing Rate
MRI	Magnetic Resonance Imaging
MSR	Maximum Sensor Rate
MTR	Maximum Tracking Rate
MV	Minute Ventilation
NASPE	North American Society of Pacing and Electrophysiology
NSR	Normal Sinus Rhythm
PAC	Premature Atrial Contraction
PAT	Paroxysmal Atrial Tachycardia
PES	Programmed Electrical Stimulation
PMT	Pacemaker-Mediated Tachycardia
PRM	Programmer/Recorder/Monitor
PSA	Pacing System Analyzer
PTM	Patient Triggered Monitor
PVARP	Post-Ventricular Atrial Refractory Period
PVC	Premature Ventricular Contraction
RAAT	Right Atrial Automatic Threshold
RADAR	Radio Detection and Ranging
RF	Radio Frequency
RTTE	Radio and Telecommunications Terminal Equipment
RV	Right Ventricular
RVAT	Right Ventricular Automatic Threshold
RVRP	Right Ventricular Refractory Period
SCD	Sudden Cardiac Death
SDANN	Standard Deviation of Averaged Normal-to-Normal R-R intervals
SRD	Sustained Rate Duration
SVT	Supraventricular Tachycardia

TARP	Total Atrial Refractory Period
TENS	Transcutaneous Electrical Nerve Stimulation
V	Ventricular
VF	Ventricular Fibrillation
VFib	Ventricular Fibrillation
VRP	Ventricular Refractory Period
VRR	Ventricular Rate Regulation
VT	Ventricular Tachycardia
VTR	Ventricular Tachycardia Response

The following are trademarks of Boston Scientific Corporation or its affiliates:

AcuShock, ApneaScan, AP Scan, AUTOGEN, COGNIS, DYNAGEN, EASYVIEW, ENDURALIFE, ENERGEN, IMAGEREADY, INCEPTA, INOGEN, LATITUDE, Onset/Stability, ORIGIN, PaceSafe, PUNCTUA, Quick Capture, Quick Convert, QUICK NOTES, RHYTHM ID, RHYTHMMATCH, RightRate, Safety Core, Smart Blanking, SmartDelay, VectorGuide, VITALITY, ZIP, ZOOM, ZOOMVIEW.

Остаряла версия. Да не се използва.
 Zastaralá verze. Nepoužívat.
 Forældet version. Må ikke anvendes.
 Version überholt. Nicht verwenden.
 Aegunud versioon. Ärge kasutage.
 Παλιά έκδοση. Μην την χρησιμοποιείτε.
 Outdated version. Do not use.
 Versión obsoleta. No utilizar.
 Zastarjela verzija. Nemojte upotrebljavati.
 Úreлт útgáfa. Notið ekki.
 Versione obsoleta. Ne pas utiliser.
 Pasenusi verzija. Neizmantot.
 Elavult versija. Nenaudokite.
 Dit is een verouderde versie. Niet gebruiken.
 Wersja przeterminowana. Nie używać.
 Versão obsoleta. Não utilize.
 Versiune expirată. A nu se utiliza.
 Zastaraná verzia. Nepoužívať.
 Vanhentunut versio. Älä käytä.
 Föråldrad version. Använd ej.
 Güncel olmayan sürüm. Kullanmayın.

Остаряла версия. Да не се използва.
Zastaralá verze. Nepoužívat.
Forældet version. Må ikke anvendes.
Version überholt. Nicht verwenden.
Aegunud versioón. Ærge kasutage.
Παλιά έκδοση. Μην την χρησιμοποιείτε.
Outdated version. Do not use.
Versión obsoleta. No utilizar.
Zastarjela verzija. Nemojte upotrebljavati.
Úreilt útgáfa. Notið ekki.
Versione obsoleta. Ne pas utiliser.
Novecojsi versija. Non utilizzare.
Pasenusi versija. Neizmantot.
Elavult verzió. Ne használja!
Dit is een verouderde versie. Niet gebruiken.
Wersja przeterminowana. Nie używać.
Versão obsoleta. Não utilize.
Versiune expirată. A nu se utiliza.
Zastarana verzija. Nepoužívať.
Vanhentunut versio. Älä käytä.
Föråldrad version. Använd ej.
Güncel olmayan sürüm. Kullanmayın.

TABLE OF CONTENTS

USING THE PROGRAMMER/RECORDER/MONITOR.....	1-1
CHAPTER 1	
ZOOM LATITUDE Programming System	1-2
Software Terminology and Navigation.....	1-2
Main Screen	1-2
PRM Mode Indicator.....	1-3
ECG/EGM Display	1-3
Toolbar	1-5
Tabs.....	1-5
Buttons.....	1-5
Icons.....	1-5
Common Objects	1-7
Use of Color	1-7
Demonstration Mode	1-8
Communicating with the Pulse Generator.....	1-8
ZIP Telemetry	1-8
Starting a Wanded Telemetry Session.....	1-9
Starting a ZIP Telemetry Session.....	1-9
Ending a Telemetry Session.....	1-9
ZIP Telemetry Security	1-10
ZIP Telemetry Security	1-12
Indications-Based Programming (IBP).....	1-14
Manual Programming	1-16
DIVERT THERAPY	1-16
STAT SHOCK	1-16
STAT PACE	1-17
Data Management.....	1-18
Patient Information	1-18
Data Storage	1-18
Device Memory.....	1-19
Print	1-19
Safety Mode	1-20
Backup Pacemaker	1-20
Backup Defibrillator	1-21
TACHYARRHYTHMIA DETECTION	2-1
CHAPTER 2	
Device Mode	2-2
Ventricular Tachy Mode	2-2
Electrocautery Protection Mode.....	2-2
MRI Protection Mode.....	2-3
Rate Sensing.....	2-4
Calculating Rates and Refractory Periods	2-5
Ventricular Rate Thresholds and Zones	2-5
CRT Delivery Zone and Tachyarrhythmia Zones.....	2-6

Use of Atrial Information	2-6
Ventricular Detection	2-7
Ventricular Detection Enhancement Suites	2-7
Ventricular Redetection	2-11
Ventricular Post-shock Detection Enhancements	2-12
Ventricular Detection Details	2-12
TACHYARRHYTHMIA THERAPY	3-1
CHAPTER 3	
Ventricular Therapy	3-2
Ventricular Therapy Prescription	3-2
Ventricular Therapy Selection	3-3
Ventricular Redetection after Ventricular Therapy Delivery	3-6
Ventricular Redetection after Ventricular ATP Therapy	3-6
Ventricular Redetection after Ventricular Shock Therapy	3-7
Antitachycardia Pacing Therapies and Parameters	3-7
Burst Parameters	3-8
Coupling Interval and Coupling Interval Decrement	3-9
Burst Cycle Length (BCL)	3-10
Minimum Interval	3-11
Burst Scheme	3-11
Ramp Scheme	3-11
Scan Scheme	3-12
Ramp/Scan Scheme	3-12
ATP Pulse Width and ATP Amplitude	3-13
Ventricular ATP Time-out	3-13
QUICK CONVERT ATP	3-14
Ventricular Shock Therapy and Parameters	3-15
Ventricular Shock Vector	3-15
Ventricular Shock Energy	3-15
Charge Time	3-16
Waveform Polarity	3-17
Committed Shock/Reconfirmation of the Ventricular Arrhythmia	3-18
PACING THERAPIES	4-1
CHAPTER 4	
Pacing Therapies	4-2
Device Programming Recommendations	4-3
Maintaining CRT	4-4
Basic Parameters	4-5
Brady Mode	4-6
Lower Rate Limit (LRL)	4-8
Maximum Tracking Rate (MTR)	4-9
Maximum Sensor Rate (MSR)	4-11
Runaway Protection	4-12
Ventricular Pacing Chamber	4-12
Pulse Width	4-13
Amplitude	4-14
PaceSafe	4-14
Sensitivity	4-25
Post-Therapy Pacing	4-28
Post-Shock Pacing Delay	4-29

Post-Therapy Period	4-29
Temporary Brady Pacing.....	4-29
Rate Adaptive Pacing and Sensor Trending	4-30
Rate Adaptive Pacing	4-30
Accelerometer	4-31
Minute Ventilation (MV).....	4-35
Sensor Trending	4-43
Atrial Tachy Response.....	4-46
ATR Mode Switch.....	4-46
Ventricular Rate Regulation (VRR)	4-49
Biventricular Trigger	4-50
Atrial Flutter Response (AFR)	4-50
PMT Termination.....	4-51
Rate Enhancements	4-52
Tracking Preference	4-52
Rate Hysteresis	4-53
Rate Smoothing	4-54
Rate Smoothing Example Based on a Dual-Chamber Tracking Mode.....	4-56
Lead Configuration.....	4-57
Left Ventricular Electrode Configuration	4-57
AV Delay	4-61
Paced AV Delay	4-61
Sensed AV Delay	4-62
SmartDelay Optimization	4-64
Refractory	4-66
A-Refractory - PVARP	4-66
A Refractory - same chamber	4-69
RV-Refractory (RVRP)	4-69
LV-Refractory (LVRP)	4-70
Left Ventricular Protection Period (LVPP)	4-70
Cross-Chamber Blanking.....	4-70
Noise Response	4-75
Ventricular Tachy Sensing Interactions.....	4-77
SYSTEM DIAGNOSTICS	5-1
CHAPTER 5	
Summary Dialog	5-2
Battery Status	5-2
Capacitor Re-formation	5-6
Charge Time Measurement.....	5-6
Last Delivered Ventricular Shock	5-6
Leads Status	5-7
Lead Tests.....	5-11
Intrinsic Amplitude Test.....	5-12
Lead Impedance Test	5-13
Pace Threshold Test.....	5-14
LV VectorGuide.....	5-17

PATIENT DIAGNOSTICS AND FOLLOW UP	6-1
CHAPTER 6	
Therapy History	6-2
Arrhythmia Logbook	6-2
Snapshot.....	6-8
Histograms	6-9
Counters	6-10
Ventricular Tachy Counters	6-10
Brady/CRT Counters	6-11
Heart Rate Variability (HRV).....	6-11
Trends.....	6-14
Post Implant features.....	6-21
Patient Triggered Monitor (PTM)	6-21
Beeper Feature.....	6-22
Magnet Feature	6-24
ELECTROPHYSIOLOGIC TESTING	7-1
CHAPTER 7	
EP Test Features	7-2
Temporary EP Mode.....	7-2
EP Test Screen.....	7-2
Induction Methods.....	7-4
VFib Induction.....	7-4
Shock on T Induction.....	7-5
Backup Ventricular Pacing During Atrial EP Testing.....	7-5
Programmed Electrical Stimulation (PES).....	7-6
50 Hz/Manual Burst Pacing.....	7-7
Commanded Therapy Methods	7-8
Commanded Shock.....	7-8
Commanded ATP.....	7-9
PROGRAMMABLE OPTIONS.....	A-1
APPENDIX A	
SYMBOLS ON PACKAGING.....	B-1
APPENDIX B	
Symbols on Packaging	B-1

USING THE PROGRAMMER/RECORDER/MONITOR

CHAPTER 1

This chapter contains the following topics:

- “ZOOM LATITUDE Programming System” on page 1-2
- “Software Terminology and Navigation” on page 1-2
- “Demonstration Mode” on page 1-8
- “Communicating with the Pulse Generator” on page 1-8
- “Indications-Based Programming (IBP)” on page 1-14
- “Manual Programming” on page 1-16
- “DIVERT THERAPY” on page 1-16
- “STAT SHOCK” on page 1-16
- “STAT PACE” on page 1-17
- “Data Management” on page 1-18
- “Safety Mode” on page 1-20

ZOOM LATITUDE PROGRAMMING SYSTEM

The ZOOM LATITUDE Programming System is the external portion of the pulse generator system and includes:

- Model 3120 Programmer/Recorder/Monitor (PRM)
- Model 3140 ZOOM Wireless Transmitter
- Model 2868 ZOOMVIEW Software Application
- Model 6577 Accessory Telemetry Wand

The ZOOMVIEW software provides advanced device programming and patient monitoring technology. It was designed with the intent to:

- Enhance device programming capability
- Improve patient and device monitoring performance
- Simplify and expedite programming and monitoring tasks

You can use the PRM system to do the following:

- Interrogate the pulse generator
- Program the pulse generator to provide a variety of therapy options
- Access the pulse generator's diagnostic features
- Perform noninvasive diagnostic testing
- Access therapy history data
- Store a 12 second trace of the ECG/EGM display from any screen
- Access an interactive Demonstration Mode or Patient Data Mode without the presence of a pulse generator
- Print patient data including pulse generator therapy options and therapy history data
- Save patient data

You can program the pulse generator using two methods: automatically using IBP or manually.

For more detailed information about using the PRM or ZOOM Wireless Transmitter, refer to the PRM Operator's Manual or ZOOM Wireless Transmitter Reference Guide.

SOFTWARE TERMINOLOGY AND NAVIGATION

This section provides an overview of the PRM system.

Main Screen

The main PRM screen is shown below, followed by a description of the components (Figure 1-1 Main Screen on page 1-3).

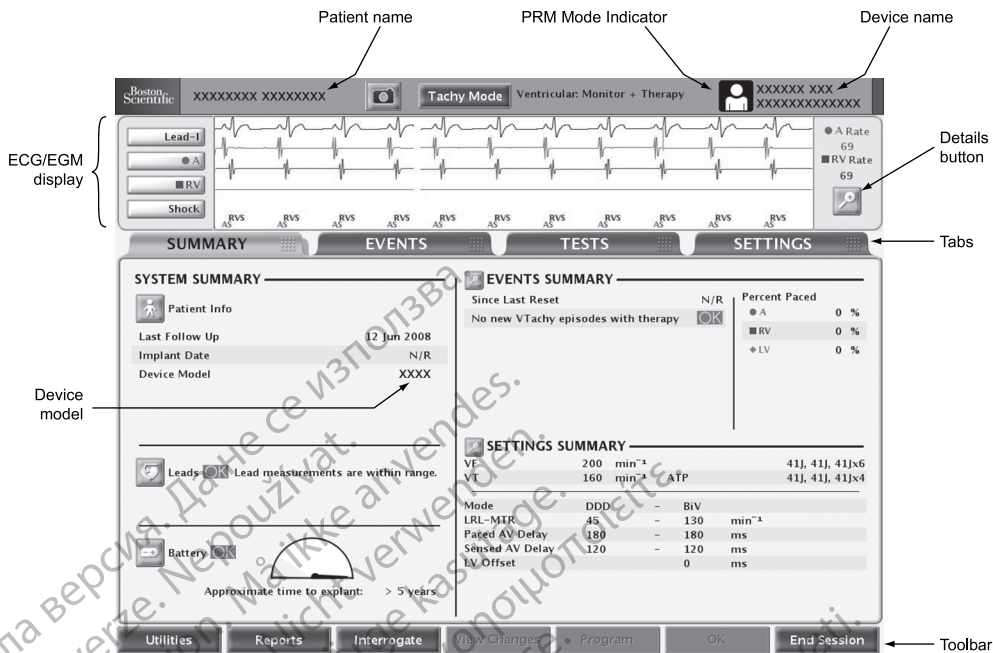

Figure 1-1. Main Screen

PRM Mode Indicator

The PRM Mode Indicator displays at the top of the screen to identify the current PRM operational mode.



Patient—indicates that the PRM is displaying data obtained by communicating with a device.



Patient Data—indicates that the PRM is displaying stored patient data.



Demo Mode—indicates that the PRM is displaying sample data and operating in demonstration mode.

ECG/EGM Display

The Wireless ECG feature is available in AUTOGEN, DYNAGEN, and INCEPTA devices.

The ECG area of the screen shows real-time status information about the patient and the pulse generator that can be useful in evaluating system performance. The following types of traces can be selected:

- Surface ECGs are transmitted from body surface lead electrodes that are connected to the PRM, and can be displayed without interrogating the pulse generator.
- Real-time EGMs are transmitted from the pace/sense or shocking electrodes, and are often used to evaluate lead system integrity and help identify faults such as lead fractures, insulation breaks, or dislodgments.

Real-time EGMs can only be displayed upon interrogation of the pulse generator. Because they rely on ZIP or wanded telemetry, they are susceptible to radio frequency interference. Significant interference may cause a break or drop-out of real-time EGMs ("ZIP Telemetry Security" on page 1-10).

- At any time, a 12 second trace of the ECG/EGM display can be stored by pressing the Snapshot button from any screen.

NOTE: If the PRM is left idle for 15 minutes (or 28 minutes if the pulse generator was in Storage Mode at interrogation) real-time EGMs are shut off. The PRM provides a dialog box allowing real-time EGMs to be restored.

NOTE: Real-time LV EGMs are available on all LV sense configurations.

NOTE: In the presence of telemetry interference, the real-time intracardiac EGM traces and markers may become misaligned from the real-time surface ECG traces. When the telemetry link has improved, re-select any of the intracardiac EGM traces to cause re-initialization.

- Wireless ECG is a form of real-time EGM that mimics a surface ECG by using a shocking lead proximal coil to can vector for measuring heart activity. Unless the device is still in Storage mode, the first (top) trace on the display will default to Wireless ECG.

CAUTION: Wireless ECG is susceptible to RF interference, and may have an intermittent or lost signal. If interference is present, especially during diagnostic testing, consider using a surface ECG instead.

NOTE: Wireless ECGs are only available with dual-coil shock leads.

You can select the Details button to enlarge the ECG/EGM screen. The following options are available:

- Show Device Markers—displays annotated event markers, which identify certain intrinsic cardiac and device-related events, and provide information such as sensed/paced events, decision of detection criteria, and therapy delivery
- Enable Surface Filter—minimizes noise on the surface ECG
- Display Pacing Spikes—shows detected pacing spikes, annotated by a marker on the surface ECG waveform
- Trace Speed—adjusts the speed of the trace (0, 25, or 50 mm/s). As the speed is increased, the time/horizontal scale is expanded
- Gain—adjusts the amplitude/vertical scale (AUTO, 1, 2, 5, 10, or 20 mm/mV) for each channel. As the gain is increased, the amplitude of the signal is enlarged

You can print real-time EGMs, which include annotated event markers, by performing the following steps:

1. Press one of the print speed keys on the PRM (e.g., speed key 25) to begin printing.
2. Press the 0 (zero) speed key to stop printing.
3. Press the paper-feed key to fully eject the last printed sheet.

You can print definitions of the annotated markers by pressing the calibration key while the EGM is printing. Alternatively you can print a full report containing the definitions of all of the annotated markers by performing the following steps:

1. From the toolbar, click the Reports button. The Reports window displays.
2. Select the Marker Legend checkbox.

3. Click the Print button. The Marker Legend Report is sent to the printer.

Toolbar

The toolbar allows you to perform the following tasks:

- Select system utilities
- Generate reports
- Interrogate and program the pulse generator
- View pending or programmed changes
- View attentions and warnings
- End your PRM session

Tabs

Tabs allow you to select PRM tasks, such as viewing summary data or programming device settings. Selecting a tab displays the associated screen. Many screens contain additional tabs, which allow you to access more detailed settings and information.

Buttons

Buttons are located on screens and dialogs throughout the application. Buttons allow you to perform various tasks, including:

- Obtain detailed information
- View setting details
- Set programmable values
- Load initial values

When a button selection opens a window in front of the Main Screen, a Close button displays in the upper-right corner of the window to allow you to close the window and return to the Main Screen.

Icons

Icons are graphic elements that, when selected, may initiate an activity, display lists or options, or change the information displayed.



Details—opens a window containing detailed information.



Patient—opens a window with patient information details.



Leads—opens a window with details on leads.



Battery—opens a window with details on the pulse generator battery.



Check—indicates that an option is selected.



Event—indicates that an event has occurred. When you view the Trends timeline on the Events tab, event icons display wherever events have occurred. Selecting an events icon displays details about the event.



Information—indicates information that is provided for reference.

Action Icons



Run—causes the programmer to perform an action.



Hold—causes the programmer to pause an action.



Continue—causes the programmer to continue an action.



Snapshot—causes the programmer to store a 12 second trace of the ECG/EGM display from any screen.

Slider Icons



Horizontal Slider—indicates that a slider object can be clicked and dragged left or right.



Vertical Slider—indicates that a slider object can be clicked and dragged up or down.

Sort Icons



Sort Ascending—indicates that Ascending sort is currently selected on a table column sort button. (e.g., 1, 2, 3, 4, 5)



Sort Descending—indicates that Descending sort is currently selected on a table column sort button. (e.g., 5, 4, 3, 2, 1)

Increment and Decrement Icons



Increment—indicates that an associated value can be incremented.



Decrement—indicates that an associated value can be decremented.

Scroll Icons

Scroll Left—indicates that an associated item can be scrolled left.



Scroll Right—indicates that an associated item can be scrolled right.



Scroll Up—indicates that an associated item can be scrolled up.



Scroll Down—indicates that an associated item can be scrolled down.

Common Objects

Common objects such as status bars, scroll bars, menus, and dialogs are used throughout the application. These operate similarly to the objects found in web browsers and other computer applications.

Use of Color

Colors and symbols are used to highlight buttons, icons, and other objects, as well as certain types of information. The use of specific color conventions and symbols is intended to provide a more consistent user experience and simplify programming. Refer to the table below to understand how colors and symbols are used on the PRM screens (Table 1–1 PRM color conventions on page 1-7).

Table 1–1. PRM color conventions

Color	Meaning	Examples	Symbol
Red	Indicates warning conditions	The selected parameter value is not allowed; click the red warning button to open the Parameter Interactions screen, which provides information about corrective action.	
		Device and patient diagnostic information that requires serious consideration.	
Yellow	Indicates conditions requiring your attention	The selected parameter value is allowed, but not recommended; click the yellow attention button to open the Parameter Interactions screen, which provides information about corrective action.	
		Device and patient diagnostic information that should be addressed.	
Green	Indicates acceptable changes or conditions	The selected parameter value is allowed, but is still pending.	
		There is no device or patient diagnostic information requiring your specific attention.	
White	Indicates the value that is currently programmed		

DEMONSTRATION MODE

The PRM includes a Demonstration Mode feature, which enables the PRM to be used as a self-teaching tool. When selected, this mode allows you to practice PRM screen navigation without interrogating a pulse generator. You can use Demonstration Mode to familiarize yourself with many of the specific screen sequences that will display when interrogating or programming a specific pulse generator. You can also use Demonstration Mode to examine available features, parameters, and information.

To access Demonstration Mode, select the appropriate PG from the Select PG screen, and then select Demo from the Select PG Mode dialog. When the PRM is operating in Demonstration Mode, the PRM Mode Indicator displays the Demo Mode icon. The pulse generator cannot be programmed when the PRM is operating in Demonstration Mode. Exit the Demonstration Mode before attempting to interrogate or program the pulse generator.

COMMUNICATING WITH THE PULSE GENERATOR

The PRM communicates with the pulse generator using a telemetry wand.

After initiating communication with the wand, the PRM can use wandless ZIP telemetry (two-way RF communication) to interface with RF capable pulse generator models.

Telemetry is required to:

- Direct commands from the PRM system, such as:
 - INTERROGATE
 - PROGRAM
 - STAT SHOCK
 - STAT PACE
 - DIVERT THERAPY
- Modify device parameter settings
- Conduct EP testing
- Conduct diagnostic tests including the following:
 - Pacing impedance tests
 - Pacing threshold tests
 - Intrinsic amplitude tests
- Perform manual capacitor re-form

ZIP Telemetry

ZIP telemetry is available in AUTOGEN, DYNAGEN, INOGEN, and ORIGEN devices and operates in the MICS (Medical Implant Communication Service) telemetry band with a transmit frequency of 402 to 405 MHz. ZIP telemetry is available in INCEPTA, ENERGEN, PUNCTUA, and COGNIS devices and operates with a transmit frequency of 869.85 MHz.

ZIP telemetry is a wandless, two-way RF communication option that allows the PRM system to communicate with these RF capable pulse generators.

- For AUTOGEN, DYNAGEN, INOGEN, and ORIGEN devices, RF communication is enabled by the ZOOM Wireless Transmitter unit connected to the PRM. When initiating communication, wanded telemetry is needed. When ZIP telemetry is ready for use, a

message will display on the PRM screen indicating that the wand can be removed. Otherwise, the session will continue with wanded telemetry.

- For INCEPTA, ENERGEN, PUNCTUA, and COGNIS devices, when a wanded telemetry session is initiated, the PRM checks the pulse generator's telemetry capability. If the PRM detects a pulse generator with ZIP telemetry capability, a message will display indicating that ZIP telemetry is available and the wand can be removed. Otherwise, the session will continue with wanded telemetry.

ZIP telemetry offers the following advantages over traditional wanded telemetry:

- The faster data transmission speed means less time is required for device interrogation
- Data transmission over a longer distance (within 3 m [10 ft]) minimizes the need to keep the wand in the sterile field during implant, which may reduce the risk of infection
- Continuous telemetry is possible during the entire implant procedure, allowing monitoring of pulse generator performance and lead integrity during implant
- Allows the physician to continue with the operating procedure while the device is being programmed for the patient

Regardless of whether ZIP telemetry is being used, wanded communication is still available.

Starting a Wanded Telemetry Session

Follow this procedure to begin a wanded telemetry communication session:

1. Make sure the telemetry wand is connected to the PRM system and is available throughout the session.
2. Position the wand over the pulse generator at a distance not greater than 6 cm (2.4 inches).
3. Use the PRM to Interrogate the pulse generator.
4. Retain the wand position whenever communication is required.

Starting a ZIP Telemetry Session

Follow this procedure to begin a ZIP telemetry communication session:

1. For AUTOGEN, DYNAGEN, INOGEN, and ORIGEN devices, verify that the ZOOM Wireless Transmitter is connected to the PRM via the USB cable and that the green light on top of the transmitter is illuminated (indicating the transmitter is ready for use).
2. Start a wanded telemetry session. Verify that the wand cord is within reach of the pulse generator to enable the use of wanded telemetry should it become necessary.
3. Keep the telemetry wand in position until either a message appears, indicating that the telemetry wand may be removed from proximity of the pulse generator, or the ZIP telemetry light illuminates on the PRM system.

Ending a Telemetry Session

Select the End Session button to quit a telemetry session and return to the startup screen. You can choose to end the session or return to the current session. Upon ending a session, the PRM system terminates all communication with the pulse generator.

ZIP Telemetry Security

The following ZIP Telemetry Security information applies to AUTOGEN, DYNAGEN, INOGEN, and ORIGEN devices which operate with a transmit frequency of 402 to 405 MHz.

The pulse generator contains a compliant low-power transceiver. The pulse generator can only be interrogated or programmed by RF signals that employ the proprietary ZIP telemetry protocol. The pulse generator verifies that it is communicating with a ZOOMVIEW system before responding to any RF signals. The pulse generator stores, transmits, and receives individually identifiable health information in an encrypted format.

ZIP telemetry is possible when all of the following conditions are met:

- ZIP telemetry for the PRM is enabled
- The ZOOM Wireless Transmitter is connected to the PRM via the USB cable
- The indicator light on top of the ZOOM Wireless Transmitter is green; indicating the transmitter is ready for use
- The pulse generator is within range of the PRM system
- The pulse generator has not reached Explant; note that a total of 1.5 hours of ZIP telemetry will be available after the pulse generator reaches Explant
- The pulse generator battery capacity is not depleted
- Pulse generator is not in MRI Protection Mode

In order to meet local communications rules and regulations; ZIP telemetry should not be used when the pulse generator is outside its normal operating temperature of 20°C–45°C (68°F–113°F).

Communication can be supported between multiple PRMs and pulse generators at a time, as independent sessions. Signals from other sessions using RF communication or interference from other RF sources may interfere with or prevent ZIP telemetry communication.

CAUTION: RF signals from devices that operate at frequencies near that of the pulse generator may interrupt ZIP telemetry while interrogating or programming the pulse generator. This RF interference can be reduced by increasing the distance between the interfering device and the PRM and pulse generator. Examples of devices that may cause interference in the 869.85 MHz frequency band include:

- Cordless phone handsets or base stations
- Certain patient monitoring systems

Radio frequency interference may temporarily disrupt ZIP telemetry communication. The PRM will normally reestablish ZIP communication when the RF interference ends or subsides. Because continued RF interference may prevent ZIP telemetry communication, the system is designed to use wanded telemetry when ZIP telemetry is not available.

If ZIP telemetry is not available due to interference or if the ZOOM Wireless Transmitter is unplugged or not functioning properly, wanded telemetry communication with the PRM can be established. The system provides the following feedback to indicate that ZIP telemetry is not available:

- The ZIP telemetry indicator light on the PRM turns off
- The green indicator light on the ZOOM Wireless Transmitter is off
- If event markers and/or EGMs are activated, transmission of the event markers and/or EGMs will be interrupted

- If a command or other action has been requested, the PRM displays a notification indicating the wand should be placed in range of the pulse generator

ZIP telemetry operates consistently with wanded telemetry—no programming step can be completed unless the entire programming command has been received and confirmed by the pulse generator.

The pulse generator cannot be misprogrammed as a result of interrupted ZIP telemetry. Interruptions of ZIP telemetry may be caused by RF signals that operate at frequencies near that of the pulse generator and are strong enough to compete with the ZIP telemetry link between the pulse generator and the PRM. Significant interference may result in a break or drop-outs of real-time EGMs. If commands are interrupted, the PRM displays a message to place the wand on the pulse generator. Repeated displays of this message may indicate the presence of intermittent interference. These situations can be resolved by repositioning the ZOOM Wireless Transmitter attached to the PRM or by using standard wanded telemetry. There will be no interruption of device functionality or therapy during this period.

NOTE: *When both ZIP and wanded telemetry are being used (for example, switching from ZIP to wanded because of the presence of interference), the pulse generator will communicate with the programmer by ZIP telemetry when possible. If wanded telemetry only is desired, set the Communication Mode (accessed via the Utilities button) to use the wand for all telemetry.*

NOTE: *To conserve battery longevity, a ZIP telemetry session will be terminated if the pulse generator completely loses communication with the PRM for a continuous period of one hour (or 73 minutes if the device was in Storage Mode at interrogation). Wanded telemetry must be used to re-establish communication with the pulse generator after this period has elapsed.*

Considerations for Reducing Interference

Increasing the distance from the source of interfering signals may enable the use of the ZIP telemetry channel.

Repositioning the ZOOM Wireless Transmitter may improve ZIP telemetry performance. If ZIP telemetry performance is not satisfactory, the option of using wanded telemetry is available.

Depending on the environment and PRM orientation relative to the pulse generator, the system is capable of maintaining ZIP telemetry communication at distances up to 3 m (10 ft). For optimum ZIP telemetry communication, position the ZOOM Wireless Transmitter within 3 m (10 ft) of the pulse generator and remove any obstruction between the ZOOM Wireless Transmitter and the pulse generator.

Positioning the ZOOM Wireless Transmitter at least 1 m (3 ft) away from walls or metal objects and ensuring the pulse generator (prior to implant) is not in direct contact with any metal objects may reduce signal reflection and/or signal blocking.

Avoid placing the ZOOM Wireless Transmitter in close proximity to monitors, high-frequency electro-surgical equipment, or strong magnetic fields since the telemetry link may be impaired.

Ensuring there are no obstructions (e.g., equipment, metal furniture, people, or walls) between the ZOOM Wireless Transmitter and pulse generator may improve signal quality. Personnel or objects that momentarily move between the ZOOM Wireless Transmitter and pulse generator during ZIP telemetry may temporarily interrupt communication, but will not affect device functionality or therapy.

Checking the time required to complete an interrogation after ZIP telemetry is established can provide an indication of whether interference is present. If an interrogation using ZIP telemetry takes less than 20 seconds, the current environment is likely free of interference. Interrogation times longer than 20 seconds (or short intervals of EGM drop-outs) indicate that interference may be present.

ZIP Telemetry Security

The following ZIP Telemetry Security information applies to INCEPTA, ENERGEN, PUNCTUA, and COGNIS devices which operate with a transmit frequency of 869.85 MHz.

The pulse generator contains a compliant low-power transceiver. The pulse generator can only be interrogated or programmed by RF signals that employ the proprietary ZIP telemetry protocol. The pulse generator verifies that it is communicating with a ZOOMVIEW system before responding to any RF signals. The pulse generator stores, transmits, and receives individually identifiable health information in an encrypted format.

ZIP telemetry is possible when all of the following conditions are met:

- ZIP telemetry for the PRM is enabled
- The pulse generator has RF communication capabilities
- The ZIP telemetry channel is available for use
- The pulse generator is within range of the PRM system
- The pulse generator has not reached Explant; note that a total of 1.5 hours of ZIP telemetry will be available after the pulse generator reaches Explant
- The pulse generator battery capacity is not depleted

In order to meet local communications rules and regulations, ZIP telemetry should not be used when the pulse generator is outside its normal operating temperature of 20°C–43°C (68°F–109°F).

Communication is supported between one PRM and one pulse generator at a time. If there is a PRM–pulse generator communication session already occurring in the vicinity, a second session will not be allowed to start; wanded communication will be necessary in this case.

The PRM notifies you if ZIP telemetry is unavailable because of other sessions already in progress.

RF signals in the same frequency band used by the system may interfere with ZIP telemetry communication. These interfering signals include:

- Signals from other pulse generator/PRM system RF communication sessions after the maximum number of independent sessions has been reached. Other nearby pulse generators and PRMs using ZIP telemetry may prevent ZIP telemetry communication.
- Interference from other RF sources.

CAUTION: RF signals from devices that operate at frequencies near that of the pulse generator may interrupt ZIP telemetry while interrogating or programming the pulse generator. This RF interference can be reduced by increasing the distance between the interfering device and the PRM and pulse generator. Examples of devices that may cause interference in the 869.85 MHz frequency band include:

- Cordless phone handsets or base stations
- Certain patient monitoring systems

Radio frequency interference may temporarily disrupt ZIP telemetry communication. The PRM will normally reestablish ZIP communication when the RF interference ends or subsides. Because continued RF interference may prevent ZIP telemetry communication, the system is designed to use wanded telemetry when ZIP telemetry is not available.

If ZIP telemetry is not available, wanded telemetry communication with the PRM can be established. The system provides the following feedback to indicate that ZIP telemetry is not available:

- The ZIP telemetry indicator light on the PRM turns off
- If event markers and/or EGMs are activated, transmission of the event markers and/or EGMs is interrupted
- If a command or other action has been requested, the PRM displays a notification indicating the wand should be placed in range of the pulse generator

ZIP telemetry operates consistently with wanded telemetry—no programming step can be completed unless the entire programming command has been received and confirmed by the pulse generator.

The pulse generator cannot be misprogrammed as a result of interrupted ZIP telemetry. Interruptions of ZIP telemetry may be caused by RF signals that operate at frequencies near that of the pulse generator and are strong enough to compete with the ZIP telemetry link between the pulse generator and the PRM. Significant interference may result in a break or drop-outs of real-time EGMs. If commands are interrupted, the PRM displays a message to place the wand on the pulse generator. Repeated displays of this message may indicate the presence of intermittent interference. These situations can be resolved by repositioning the PRM or using standard wanded telemetry. There will be no interruption of device functionality or therapy during this period.

NOTE: When both ZIP and wanded telemetry are being used (for example, switching from ZIP to wanded because of the presence of interference), the pulse generator will communicate with the programmer by ZIP telemetry when possible. If wanded telemetry only is desired, set the Communication Mode (accessed via the Utilities button) to use the wand for all telemetry.

NOTE: To conserve battery longevity, a ZIP telemetry session will be terminated if the pulse generator completely loses communication with the PRM for a continuous period of one hour (or 73 minutes if the device was in Storage Mode at interrogation). Wanded telemetry must be used to re-establish communication with the pulse generator after this period has elapsed.

NOTE: The PRM operates on a country-specific frequency range. The PRM determines the ZIP frequency range that the pulse generator uses based on the specific device model. If the PRM and pulse generator ZIP frequency ranges do not match, it indicates that the patient has traveled outside the country in which the pulse generator was implanted. The PRM will display a message indicating that ZIP telemetry cannot be used; however, the patient's pulse generator can be interrogated by using the wand. If out-of-country interrogation is needed, contact Boston Scientific using the information on the back cover of this manual.

Considerations for Reducing Interference

Increasing the distance from the source of interfering signals may enable the use of the ZIP telemetry channel. A minimum distance of 14 m (45 ft) is recommended between the source of interference (having an average output of 50 mW or less) and both the pulse generator and PRM.

Repositioning the PRM antenna or repositioning the PRM may improve ZIP telemetry performance. If ZIP telemetry performance is not satisfactory, the option of using wanded telemetry is available.

Depending on the environment and PRM orientation relative to the pulse generator, the system is capable of maintaining ZIP telemetry communication at distances up to 12 m (40 ft). For optimum ZIP telemetry communication, position the PRM antenna within 3 m (10 ft) of the pulse generator and remove any obstruction between the PRM and the pulse generator.

Positioning the PRM at least 1 m (3 ft) away from walls or metal objects and ensuring the pulse generator (prior to implant) is not in direct contact with any metal objects may reduce signal reflection and/or signal blocking.

Ensuring there are no obstructions (e.g., equipment, metal furniture, people, or walls) between the PRM and pulse generator may improve signal quality. Personnel or objects that momentarily move between the PRM and pulse generator during ZIP telemetry may temporarily interrupt communication, but will not affect device functionality or therapy.

Checking the time required to complete an interrogation after ZIP telemetry is established can provide an indication of whether interference is present. If an interrogation using ZIP telemetry takes less than 20 seconds, the current environment is likely free of interference. Interrogation times longer than 20 seconds (or short intervals of EGM drop-outs) indicate that interference may be present.

INDICATIONS-BASED PROGRAMMING (IBP)

This feature is available in AUTOGEN, DYNAGEN, INOGEN, INCEPTA, ENERGEN, and COGNIS devices.

IBP is a tool that provides specific programming recommendations based on the patient's clinical needs and primary indications.

IBP is a clinical approach to programming that was developed based on physician consultation and case studies. The intent of IBP is to enhance patient outcomes and save time by providing base programming recommendations that you can customize as needed. IBP systematically presents the specific features intended for use with the clinical conditions you identify in the IBP user interface, and allows you to take maximum advantage of the pulse generator's capabilities.

IBP can be accessed from the Settings tab on the main application screen (Figure 1–2 Indications-based Programming screen on page 1-14).

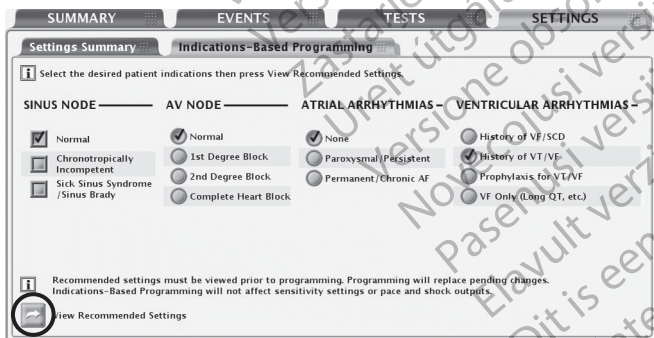

Figure 1–2. Indications-based Programming screen

Indications are clustered in general categories as illustrated above. The intent for each category of indications is described below:

- Sinus Node
 - If Normal is selected, the intent is to allow intrinsic atrial events and provide CRT pacing.
 - If Chronotropically Incompetent is selected, the intent is to provide rate-adaptive CRT pacing.
 - If Sick Sinus Syndrome is selected, the intent is to provide atrial pacing support and CRT pacing.
- AV Node

- The intent is to use nominal Paced AV Delay and Sensed AV Delay settings. The SmartDelay optimization feature may be used to adjust the AV delay.

NOTE: The selected settings for AF and Sinus Node may affect the suggested value for the setting of AV Node.

- Atrial Arrhythmias
 - If Paroxysmal/Persistent is selected, the intent is to avoid tracking atrial arrhythmias by using ATR Mode Switch when a dual-chamber pacing mode is suggested.
 - If Permanent/Chronic AF is selected, the intent is to provide rate-adaptive CRT pacing.
- Ventricular Arrhythmias
 - When History of VF/SCD or Prophylaxis for VT/VF is selected, a 2-zone configuration with the following rate thresholds and therapies is provided:
 - 180 min⁻¹ for the VF zone with QUICK CONVERT ATP and Maximum Energy Shocks enabled
 - 160 min⁻¹ for the VT zone with therapy disabled (Monitor Only)
 - When History of VT/VF is selected, a 2-zone configuration with the following rate thresholds and therapies is provided:
 - 200 min⁻¹ for the VF zone with QUICK CONVERT ATP and Maximum Energy Shocks enabled
 - 160 min⁻¹ for the VT zone with ATP and Maximum Energy Shocks enabled
 - Onset/Stability enabled
 - When VF Only is selected, the intent is to provide a single VF zone of 220 min⁻¹ with only Maximum Energy Shocks enabled.

After choosing appropriate patient indications, select the View Recommended Settings button to view a summary of the programming recommendations (Figure 1–3 Proposed Settings Summary screen on page 1-15).

NOTE: You must view the recommended settings before you can program them. Selecting the View Recommended Settings button allows you to view the settings that are recommended based on the indications that you selected. Viewing the recommended settings does not overwrite any pending (i.e., not yet programmed) parameter changes. You must choose to program or reject the recommended settings after viewing them. If you choose to reject the recommended settings, all of your pending settings will be restored. If you choose to program the recommended settings, any pending parameter changes will be overwritten, with the exception of sensitivity and therapy outputs, which are independent of IBP.

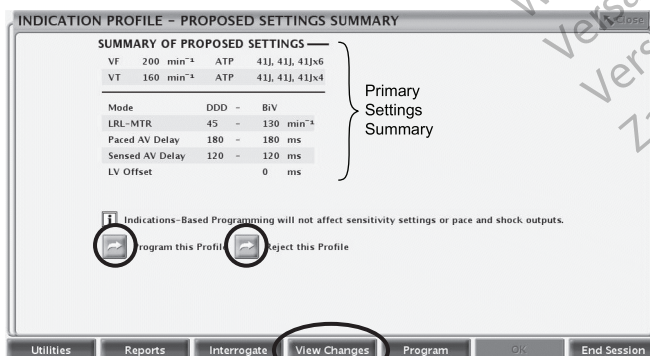

Figure 1–3. Proposed Settings Summary screen

The Proposed Settings Summary screen displays the primary programming recommendations. Additional details about all changed parameters are available by selecting the View Changes button from the toolbar. You have the option to program the proposed settings or reject them, as long as telemetry is still engaged:

- Program—select the Program this Profile button to accept the proposed settings.
- Reject—select the Reject this Profile button to reject the proposed settings; this action will return you to the main IBP screen with no changes made.

MANUAL PROGRAMMING

Manual programming controls such as sliders and menus are available to allow you to individually adjust pulse generator program settings.

Manual programming controls are located on the Settings Summary tab, which can be accessed from the Settings tab or by selecting the Settings Summary button on the Summary tab. Refer to other feature descriptions in this manual for specific manual programming information and instructions. Refer to "Programmable Options" on page A-1 for detailed listings of available settings.

DIVERT THERAPY

This feature is available in AUTOGEN, DYNAGEN, INOGEN, ORIGEN, INCEPTA, ENERGEN, PUNCTUA, and COGNIS devices.

When the pulse generator is charging to deliver a shock, the shock delivery may be diverted from the patient. If diverted, the shock does not count as one of the total number of shocks that may be delivered during an episode. If redetection occurs and more shock therapy is required, and if more shocks are available in the therapy prescription, the pulse generator will charge again to deliver subsequent shocks.

Also, the DIVERT THERAPY key can be pressed to divert ATP therapy in midburst. If redetection occurs, the ATP scheme will not be used again and the next programmed therapy in the sequence will be initiated.

1. If you are not already in a session, position the telemetry wand within range of the pulse generator and start a communication session.
2. Press the DIVERT THERAPY key. A message window will appear indicating that a divert attempt is being made.
3. If using wanded telemetry, maintain the wand position until the message window disappears, indicating the shock has been diverted. Prematurely removing the wand (breaking the telemetry link) may allow the pulse generator to continue charging and to deliver the shock.

NOTE: There is a 500 ms delay between the end of charging and shock delivery designed to provide a minimum period for the DIVERT THERAPY command. After this time, pressing DIVERT THERAPY may not divert the shock.

The DIVERT THERAPY key can be used to terminate any diagnostic test in progress, as well as Electrocautery Protection Mode (if using wanded telemetry, maintain the telemetry wand position until the divert function is complete to avoid interruption to the divert command).

The DIVERT THERAPY key can also be used to terminate MRI Protection Mode.

STAT SHOCK

This feature is available in AUTOGEN, DYNAGEN, INOGEN, ORIGEN, INCEPTA, ENERGEN, PUNCTUA, and COGNIS devices.

A nonprogrammable, maximum-output STAT SHOCK can be delivered to the patient at any time during a communication session. The STAT SHOCK can be delivered when the pulse generator's Tachy Mode is programmed to any mode. This function does not affect the programmed shock sequences (lower-energy shocks can be delivered following a STAT SHOCK) and does not count as one of the total number of shocks in a therapy sequence for a given episode. The output of the STAT SHOCK is at the maximum-output energy and at the programmed polarity and waveform; STAT SHOCK is always committed regardless of programmed parameters.

1. If you are not already in a session, position the telemetry wand within range of the pulse generator.
2. Press the STAT SHOCK key. A message window appears with information about the shock and instructions to initiate the shock.
3. To initiate the shock, press the STAT SHOCK key again. A different message window appears indicating that STAT SHOCK is in process. When the shock has been delivered, the message window disappears.
4. Subsequent high-energy STAT SHOCKS may be delivered by repeating the previous steps.

NOTE: The STAT SHOCK may be diverted using the DIVERT THERAPY key.

NOTE: Following STAT SHOCK delivery, if the Tachy Mode is programmed to Monitor Only or Monitor + Therapy, post-shock redetection is initiated (initial detection criteria and enhancements are not used). If the Tachy Mode is programmed to Monitor + Therapy and redetection determines that further therapy is required, the programmed sequence of therapy will be resumed or initiated, including ATP and/or low-energy shocks.

NOTE: STAT SHOCK will terminate Electrocautery Protection Mode and MRI Protection Mode.

STAT PACE

This feature is available in AUTOGEN, DYNAGEN, INOGEN, ORIGEN, INCEPTA, ENERGEN, PUNCTUA, and COGNIS devices.

Emergency bradycardia pacing using the STAT PACE command sets the bradycardia operation to parameters intended to ensure capture.

1. If you are not already in a session, position the telemetry wand within range of the pulse generator.
2. Press the STAT PACE key. A message window displays the STAT PACE values.
3. Press the STAT PACE key a second time. A message indicates that STAT PACE is being performed, followed by the STAT PACE values.
4. Select the Close button on the message window.
5. To stop STAT PACE, reprogram the pulse generator.

NOTE: STAT PACE will terminate Electrocautery Protection Mode and MRI Protection Mode.

CAUTION: When a pulse generator is programmed to STAT PACE settings, it will continue to pace at the high-energy STAT PACE values if it is not reprogrammed. The use of STAT PACE parameters will likely decrease device longevity.

The STAT PACE parameter values are listed below (Table 1–2 STAT PACE Parameter Values on page 1-18).

Table 1–2. STAT PACE Parameter Values

Parameter	Values
Mode	VVI
Lower Rate Limit	60 min ⁻¹
Interval	1000 ms
Pacing Chamber	BiV
Amplitude	7.5 V
Pulse Width	1.0 ms
Paced Refractory	250 ms
Post-shock Pacing	VVI

DATA MANAGEMENT

The PRM system allows you to view, print, store, or retrieve patient and pulse generator data. This section describes the PRM data management capabilities.

Patient Information

This feature is available in AUTOGEN, DYNAGEN, INOGEN, ORIGEN, INCEPTA, ENERGEN, PUNCTUA, and COGNIS devices.

Information about the patient can be stored in pulse generator memory. The information is accessible from the Summary screen by selecting the Patient icon. This information includes, but is not limited to, the following:

- Patient and physician data
- Pulse generator serial number
- Implant date
- Lead configurations
- Implant test measurements

The information can be retrieved at any time by interrogating the pulse generator and viewing it on the PRM screen or printing it as a report.

NOTE: If the data for patient date of birth, gender, or fitness level are changed within Patient Information, the corresponding value in Minute Ventilation will automatically change. Likewise, if the data for fitness level is changed within Minute Ventilation, the corresponding value in Patient Information will automatically change.

NOTE: The data entered for patient Sleep Schedule is used for the AP Scan and ApneaScan trends.

Data Storage

This feature is available in AUTOGEN, DYNAGEN, INOGEN, ORIGEN, INCEPTA, ENERGEN, PUNCTUA, and COGNIS devices.

The PRM system allows you to save pulse generator data to the PRM hard drive or a removable floppy data disk. Data saved to the PRM can also be transferred to a removable USB pen drive.

Saved pulse generator data includes, but is not limited to, the following:

- Therapy history

- Programmed parameter values
- Trending values
- HRV
- Histogram paced/sensed counters

Select the Utilities button, and then select the Data Storage tab to access the following options:

- Read Disk—allows you to retrieve saved pulse generator data from a floppy disk.
- Save All—allows you to save pulse generator data to either a floppy disk (disk must be inserted) or the PRM hard drive (if no floppy disk is detected). Data saved to a floppy disk can be retrieved using the Read Disk option described above. Data saved to the PRM can be read, deleted, or exported to a USB pen drive from the PRM startup screen. Reports are available in PDF format. Refer to the PRM Operator's Manual for more information.

NOTE: *While the data is being saved, a message on the right-hand side of the System Status screen indicates where the data is being saved.*

Consider the following when storing and retrieving pulse generator data:

- No more than 400 unique patient records may be saved to the PRM. When a pulse generator is interrogated, the PRM evaluates if there is already a record on file for this pulse generator, or if a new record will need to be created. If a new record is needed, and the PRM is at the 400 record capacity, the oldest record on file will be deleted to create space for the new patient record.
- When performing multiple patient checkups, be sure to start a new session for each patient.
- Be sure to save all pulse generator data to either a floppy disk or USB pen drive before returning a PRM to Boston Scientific, as all patient and pulse generator data will be erased from the PRM when it is returned.
- To protect patient privacy, pulse generator data can be encrypted before it is transferred to a USB pen drive.

Device Memory

This feature is available in AUTOGEN, DYNAGEN, INOGEN, ORIGEN, INCEPTA, ENERGEN, PUNCTUA, and COGNIS devices.

The Device Memory utility allows you to retrieve, save, and print pulse generator memory data, which is intended for use by a Boston Scientific representative for clinical and troubleshooting purposes. This utility should only be used when directed by a Boston Scientific representative. Digital media with device memory data contains protected health information and therefore should be handled in accordance with applicable privacy and security policies and regulations.

NOTE: *Use the Data Storage tab to access pulse generator data for clinician use ("Data Storage" on page 1-18).*

Print

You can print PRM reports by using the internal printer, or by connecting to an external printer. To print a report, select the Reports button. Then select the report you wish to print from the following categories:

- Follow-up reports
- Episode reports

- Other reports (includes device settings, patient data, and other information)

SAFETY MODE

This feature is available in AUTOGEN, DYNAGEN, INOGEN, ORIGEN, INCEPTA, ENERGEN, PUNCTUA, and COGNIS devices.

The pulse generator is equipped with dedicated Safety Core hardware that is intended to provide life-sustaining therapy if certain nonrecoverable or repeat fault conditions occur and cause a system reset. These types of faults indicate a loss of component integrity in the pulse generator's central processing unit (CPU), including the microprocessor, program code, and system memory. Using minimal hardware (i.e., unipolar lead configuration), Safety Core operates independently and acts as a backup to these components.

Safety Core also monitors the device during normal pacing; if normal pacing does not occur, Safety Core delivers an escape pace, and a system reset is initiated.

If the pulse generator experiences three resets within approximately 48 hours, the device reverts to Safety Mode and device replacement should be considered. The following will also occur:

- The pulse generator will beep 16 times every 6 hours. This beeping is disabled once the device has been interrogated with a PRM.

WARNING: The Beeper will no longer be usable following an MRI scan. Coming in contact with the strong magnetic field of an MRI scanner causes a permanent loss of the Beeper volume. This cannot be recovered, even after leaving the MR scan environment and exiting MRI Protection Mode. Before an MRI procedure is performed, a physician and patient should weigh the benefit of the MR procedure against the risk of losing the Beeper. It is strongly recommended that patients are followed on LATITUDE NXT after an MRI scan if they are not already. Otherwise, an in-clinic follow-up schedule of every three months is strongly recommended to monitor device performance.

- ZIP telemetry is unavailable for communicating with the PRM when Safety Mode is active; wand telemetry must be used instead.
- For AUTOGEN, DYNAGEN, INOGEN, and ORIGEN devices, LATITUDE NXT will alert that Safety Mode has been activated. For INCEPTA, ENERGEN, PUNCTUA, and COGNIS devices, LATITUDE NXT remote monitoring is unavailable.
- Upon interrogation, a warning screen is displayed indicating that the pulse generator is in Safety Mode, and directing you to contact Boston Scientific.

Backup Pacemaker

Safety Mode provides biventricular pacing, with the following fixed parameters:

- Brady Mode—VVI
- LRL—72.5 min⁻¹
- Pulse Amplitude—5.0 V
- Pulse Width—1.0 ms
- RV Refractory Period (RVRP)—250 ms
- RV Sensitivity—AGC 0.25 mV
- RV lead configuration—Unipolar
- Ventricular Pacing Chamber—BiV
- LV Offset—0 ms
- LV lead configuration—Unipolar (LV tip to Can)

- Noise Response—VOO
- Post-Shock Pacing Delay—3 sec

WARNING: In the rare event that non-recoverable or repeat fault conditions occur while the device is programmed in MRI Protection Mode, the subsequent device behavior will be determined by the MRI Protection Brady Mode setting.

- If MRI Brady Mode is set to Off, the device will enter Safety Mode (permanent VVI unipolar pacing and tachycardia therapy enabled).
- If MRI Brady Mode is set to asynchronous pacing (AOO, VOO, DOO), both bradycardia therapy and tachycardia therapy will be permanently disabled.

Backup Defibrillator

When Safety Mode is activated, Tachy Mode is automatically programmed to Monitor + Therapy to provide single-zone tachyarrhythmia detection and therapy. Tachy Mode may still be programmed to Off while in Safety Mode.

NOTE: If additional faults are detected while in Safety Mode, tachyarrhythmia therapy will be disabled.

While in Safety Mode, the tachyarrhythmia therapy is limited to 5 maximum-energy committed shocks per episode.

Tachyarrhythmia detection and therapy parameters are fixed as follows:

- VF Rate Threshold—165 min⁻¹
- Duration—1 sec
- Shock polarity—initial
- Shock waveform—biphasic
- Shock Vector—V-TRIAD

Magnet application will immediately inhibit therapy, although charging may continue. After the magnet has been applied for 1 second, therapy is diverted and detection is inhibited. The magnet must then be removed for 2 seconds in order to allow detection to continue. Also, Safety Mode disables normal beeping behavior following magnet application.

WARNING: In the rare event that non-recoverable or repeat fault conditions occur while the device is programmed in MRI Protection Mode, the subsequent device behavior will be determined by the MRI Protection Brady Mode setting.

- If MRI Brady Mode is set to Off, the device will enter Safety Mode (permanent VVI unipolar pacing and tachycardia therapy enabled).
- If MRI Brady Mode is set to asynchronous pacing (AOO, VOO, DOO), both bradycardia therapy and tachycardia therapy will be permanently disabled.

Остаряла версия. Да не се използва.
Zastaralá verze. Nepoužívat.
Forældet version. Må ikke anvendes.
Version überholt. Nicht verwenden.
Aegunud versioón. Ärgе kasutage.
Παλιά έκδοση. Μην την χρησιμοποιείτε.
Outdated version. Do not use.
Versión obsoleta. No utilizar.
Zastarjela verzija. Nemojte upotrebljavati.
Úreilt útgáfa. Notið ekki.
Versione obsoleta. Non utilizzare.
Zastarjela verzija. Neizmantot.
Úreilt útgáfa. Notið ekki.
Novecojsi versija. Nenaudokite.
Pasenusi versija. Non utilizzare.
Elavult verzió. Ne használja!
Utdatert versjon. Skal ikke brukes.
Wersja przeterminowana. Nie używać.
Versão obsoleta. Não utilize.
Versiune expirată. A nu se utiliza.
Zastaraná verzia. Nepoužívať.
Vanhentunut versio. Älä käytä.
Föråldrad version. Använd ej.
Güncel olmayan sürüm. Kullanmayın.

TACHYARRHYTHMIA DETECTION

CHAPTER 2

This chapter contains the following topics:

- “Device Mode” on page 2-2
- “Rate Sensing” on page 2-4
- “Ventricular Detection” on page 2-7

DEVICE MODE

The Device Mode allows you to program the device to provide the type of therapy and detection desired.

Ventricular Tachy Mode

This feature is available in AUTOGEN, DYNAGEN, INOGEN, ORIGEN, INCEPTA, ENERGEN, PUNCTUA, and COGNIS devices.

The Ventricular Tachy Mode controls the availability of the detection and therapy functions in the ventricle (Table 2–1 Device feature availability in the Ventricular Tachy Mode settings on page 2-2).

You can program the Ventricular Tachy Mode to the following modes:

- Off—disables ventricular tachyarrhythmia detection and automatic ventricular therapy delivery. This mode is useful during implant or explant, when connecting the leads to or disconnecting them from the pulse generator.
- Monitor Only—enables ventricular tachyarrhythmia detection and episode storage, but does not automatically deliver therapy to the patient. This mode is useful in controlled environments, such as during EP testing, exercise testing, and immediately postoperative, where alternate therapy (e.g., external defibrillation) is available.
- Monitor + Therapy—enables the full range of ventricular detection and ventricular therapy options.

Table 2–1. Device feature availability in the Ventricular Tachy Mode settings

Device features	Ventricular Tachy Mode		
	Off	Monitor Only	Monitor + Therapy
Rate sensing	X ^a	X	X
Bradycardia pacing	X	X	X
Ventricular Detection/Therapy History	X ^b	X	X
STAT SHOCK	X	X	X
STAT PACE	X	X	X
Real-time annotated EGMs	X	X	X
Ventricular tachyarrhythmia detection		X	X
Commanded Ventricular ATP		X	X ^c
Commanded Ventricular Shock		X	X
Ventricular EP Test		X ^d	X ^d
Automatic ventricular tachyarrhythmia therapy			X

- In order to enable ventricular sensing when the Ventricular Tachy Mode is programmed to Off, you must program the Brady Mode to a mode with ventricular sensing.
- While programmed to Off Mode, the pulse generator will store only STAT SHOCK in history.
- When the Ventricular Tachy Mode is Monitor + Therapy, the EP Temp V Mode must be programmed to Monitor Only in order to use the Commanded Ventricular ATP.
- Not all forms of EP Tests are available in this mode.

Electrocautery Protection Mode

This feature is available in AUTOGEN, DYNAGEN, INOGEN, ORIGEN, INCEPTA, ENERGEN, PUNCTUA, and COGNIS devices.

Electrocautery Protection Mode provides asynchronous pacing at the programmed outputs and LRL. Tachyarrhythmia detection and therapy features are deactivated.

When Electrocautery Protection is enabled, the Brady Mode switches to an XOO mode (where X is determined by the programmed Brady Mode). Other pacing parameters remain at the programmed settings (including pacing output). If Brady Mode is Off prior to enabling Electrocautery Protection, it will remain Off during Electrocautery Protection. Once enabled, Electrocautery Protection does not require constant telemetry to remain active.

After cancelling Electrocautery Protection, the following modes will revert to the previously programmed settings:

- Ventricular Tachy Mode
- Brady/CRT Mode

After attempting to enable Electrocautery Protection Mode, refer to the message on the PRM screen confirming that Electrocautery Protection is active.

Except for STAT SHOCK and STAT PACE, no commanded therapies, inductions, diagnostic tests, or printing of reports will be allowed while Electrocautery Protection is enabled.

Application of a magnet while the device is in Electrocautery Protection has no effect on Tachy Mode.

Biventricular pacing with LV Offset programmed to zero will be delivered while Electrocautery Protection Mode is enabled if the programmed mode is a ventricular pacing mode.

To enable and disable Electrocautery Protection Mode, perform the following steps:

1. Select the Tachy Mode button from the top of the PRM screen.
2. Select the check box to Enable Electrocautery Protection.
3. Select the Apply Changes button to enable Electrocautery Protection Mode. A dialog window will appear, indicating that Electrocautery Protection is active.
4. Select the Cancel Electrocautery Protection button on the dialog window to return the device to the previously programmed mode. Electrocautery Protection can also be cancelled by selecting STAT SHOCK, STAT PACE, or DIVERT THERAPY on the PRM.

MRI Protection Mode

This feature is available in AUTOGEN, DYNAGEN, INOGEN, and ORIGEN devices with an IS-1/DF4/IS4 lead connection.

For a complete description of MRI Protection Mode, a list of MR Conditional devices, and additional information about the ImageReady MR Conditional Defibrillation System, refer to the ImageReady MR Conditional Defibrillation System MRI Technical Guide.

WARNING: AUTOGEN, DYNAGEN, INOGEN, and ORIGEN devices with an IS-1/DF4/IS4 lead connection are considered MR Conditional. For these devices, unless all of the MRI Conditions of Use are met, MRI scanning of the patient does not meet MR Conditional requirements for the implanted system. Significant harm to or death of the patient and/or damage to the implanted system may result. *All other devices covered by this manual are not MR conditional.* Do not expose patients with non-MR Conditional devices to MRI scanning. Strong magnetic fields may damage the pulse generator and/or lead system, possibly resulting in injury to or death of the patient.

For additional warnings, precautions, Conditions of Use, and potential adverse events applicable when the Conditions of Use are met or not met, refer to the ImageReady MR Conditional Defibrillation System MRI Technical Guide.

MRI Protection Mode modifies certain pulse generator functions in order to mitigate risks associated with exposing the defibrillation system to the MRI environment.

MRI Protection Mode is accessed via the Tachy Mode button. Choosing MRI Protection Mode will initiate a sequence of dialog boxes to assess the eligibility and readiness of the patient and the patient's pacing system to undergo an MR Conditional MRI scan. Detailed programming instructions, the Conditions for Use, and a comprehensive list of MRI-related warnings and precautions are provided in the ImageReady MR Conditional Defibrillation System MRI Technical Guide.

In MRI Protection Mode:

- Pacing mode options include asynchronous pacing (DOO, AOO, VOO) or no pacing (Off). Asynchronous pacing should only be used if the patient is pacing-dependent. If MRI Protection Brady Mode is programmed to Off, the patient will not receive therapy until MRI Protection Mode is exited. Off should only be used if the patient is judged to be clinically capable of receiving no pacing during the time the pulse generator is in MRI Protection Mode, including during the scan.
- Cardiac Resynchronization Therapy is suspended if MRI Protection Brady Mode is programmed to Off.
- Tachycardia therapy is suspended.
- Beeper is disabled.
- ZIP Telemetry is suspended.

MRI Protection Mode is terminated by manual exit or by setting the user-programmed automatic MRI Protection Time-out period (refer to the ImageReady MR Conditional Defibrillation System MRI Technical Guide for MRI Protection Mode programming instructions). STAT PACE, STAT SHOCK and DIVERT THERAPY will also terminate MRI Protection Mode. When MRI Protection Mode is exited, all parameters (except for the Beeper) return to the previously programmed settings.

NOTE: In situations where the MRI scan did not occur, the Beeper can be re-enabled after exiting MRI Protection Mode ("Beeper Feature" on page 6-22).

RATE SENSING

Rate sensing is critical to all detection decisions. The pulse generator relies on the following to determine cardiac cycle length:

- Bipolar electrodes in the atrium and right ventricle.
- Automatic gain-controlled sensing circuit for rate sensing. This circuit ensures proper rate sensing by compensating for changing or diminished signal amplitudes.

For CRT and bradycardia therapy decisions, rate sensing is based on RV sensed and ventricular paced events.

Calculating Rates and Refractory Periods

The pulse generator evaluates rate on an interval-by-interval basis. Following a sensed depolarization, a cycle length is measured and compared to the programmed detection parameters.

The pulse generator uses refractory periods following paced and sensed intrinsic events; intrinsic events that fall within these periods are ignored for detection purposes. The refractory periods, together with noise windows, may prevent the sensing of nonphysiologic signals and the potential delivery of unwanted therapy. The nonprogrammable refractory periods are as follows:

- 85 ms atrial refractory following an atrial sensed event
- 150 ms atrial refractory following an atrial pace in DDD(R) and DDI(R) modes
- 135 ms RV refractory following an RV sensed event
- 135 ms refractory following a capacitor charge (sensing is ignored in all chambers)
- 500 ms refractory following shock delivery (sensing is ignored in all chambers)

Ventricular Rate Thresholds and Zones

This feature is available in AUTOGEN, DYNAGEN, INOGEN, ORIGEN, INCEPTA, ENERGEN, PUNCTUA, and COGNIS devices.

The pulse generator compares each sensed RV cardiac cycle interval against the programmed Ventricular Tachyarrhythmia Rate Threshold.

A Ventricular Tachyarrhythmia Zone is a range of heart rates defined by at least one programmed Ventricular Tachyarrhythmia Rate Threshold. You can program from 1 to 3 Ventricular Tachyarrhythmia Zones, each of which can be treated by a separate therapy prescription (Table 2-2 Nominal values for Ventricular Rate Threshold configurations on page 2-5, Figure 2-1 Ventricular Tachy Detection settings on page 2-5).

Table 2-2. Nominal values for Ventricular Rate Threshold configurations

Ventricular Zone Configuration	VT-1 Zone	VT Zone	VF Zone
1 Zone	--	--	200 min ⁻¹
2 Zones	--	160 min ⁻¹	200 min ⁻¹
3 Zones	140 min ⁻¹	160 min ⁻¹	200 min ⁻¹

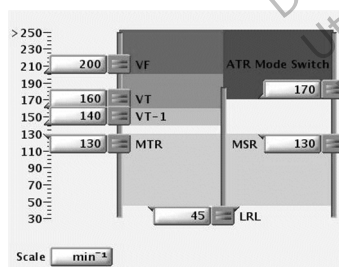

Figure 2-1. Ventricular Tachy Detection settings

- Rate thresholds in adjacent zones must differ by at least 20 min⁻¹
- The lowest Ventricular Tachyarrhythmia Rate Threshold must be at least 5 min⁻¹ higher than the MTR, MSR, and the MPR

- The lowest Ventricular Tachyarrhythmia Rate Threshold must be at least 15 min⁻¹ higher than the LRL

CRT Delivery Zone and Tachyarrhythmia Zones

This feature is available in AUTOGEN, DYNAGEN, INOGEN, ORIGEN, INCEPTA, ENERGEN, PUNCTUA, and COGNIS devices.

The device divides therapy delivery into zones based on heart rate.

- The programmed LRL and MTR/MSR/MPR define the CRT delivery zone, or the range over which CRT is delivered.
- The tachyarrhythmia zones are bounded by the lower rate threshold of the lowest tachyarrhythmia zone. It is not possible to program the CRT delivery zone and the tachyarrhythmia zones to overlap. A minimum 5 min⁻¹ difference must exist between the upper limit of the CRT delivery zone and the lower limit of the tachyarrhythmia zones.

Use of Atrial Information

This feature is available in AUTOGEN, DYNAGEN, INOGEN, ORIGEN, INCEPTA, ENERGEN, PUNCTUA, and COGNIS devices.

The atrial rate may be used to:

- Inhibit ventricular therapy in the presence of atrial fibrillation or atrial flutter
- Bypass ventricular therapy inhibitors if the ventricular rate is faster than the atrial rate

Atrial sensing can be programmed to On or Off in any dual or single chamber Brady Mode. The pulse generator will respond to atrial sensing regardless of whether an atrial lead is implanted.

There may be clinical situations in which atrial lead information is not useful (e.g., chronic atrial fibrillation, faulty or dislodged atrial lead, plugged atrial port).

CAUTION: If an atrial lead is not implanted (port is plugged instead), or an atrial lead is abandoned but remains connected to the header, device programming should be consistent with the number and type of leads actually in use.

If an atrial lead will not be used, use the following programming recommendations to ensure appropriate device behavior:

- Program the atrial lead to Off, to prevent atrial sensing and minimize accrual of atrial counters.

NOTE: An atrial EP test should not be performed if the atrial lead is programmed to Off.

CAUTION: When atrial sensing is programmed to Off in a DDI(R) or DDD(R) mode, any atrial pacing that occurs will be asynchronous. Additionally, features that require atrial sensing may not function as expected.

- Program the Brady Mode to VVI or VVI(R), to prevent atrial pacing and ensure that atrial information is not used to drive brady pacing.
- Program the following ventricular detection enhancements to Off, to ensure therapy decisions are not based on atrial measurements:
 - Initial and Post-Shock V Rate > A Rate (for Onset/Stability)

- Initial and Post-Shock AFib Rate Threshold (for Onset/Stability)
- Atrial Tachyarrhythmia Discrimination (for Rhythm ID)

NOTE: You should also review and, if necessary, adjust Stability settings.

- Program the Atrial Intrinsic Amplitude and Atrial Impedance daily lead measurements to Off to disable atrial diagnostics (e.g., atrial Amplitude and Impedance).
- During follow-up visits, consider deselecting the atrial real-time EGM.

If an atrial lead is used in the future, these programming adjustments should be reevaluated, and the pulse generator should be programmed appropriately for use with an atrial lead.

VENTRICULAR DETECTION

Ventricular detection consists of the following components:

- Initial ventricular detection
- Reconfirmation/committed shock
- Redetection and post-shock detection

Initial ventricular detection criteria consist of the programmable parameters Rate and Duration. The detection criteria may also include one of the following detection enhancement suites, which may be used during initial and post-shock ventricular detection to add specificity beyond Rate and Duration:

- Onset/Stability
- Rhythm ID

The pulse generator initiates ventricular therapy when it determines that detection is met. Ventricular detection is met when all of the following occur:

- A ventricular zone's detection window becomes and remains satisfied throughout Duration
- The ventricular zone's Duration expires
- A higher ventricular zone's detection window is not satisfied
- Detection enhancements (if programmed to On) indicate therapy
- The last detected interval is in the ventricular zone

If the above criteria are not met, therapy is not initiated and the pulse generator continues to evaluate intervals.

WARNING: During MRI Protection Mode, Tachycardia therapy is suspended. The system will not detect ventricular arrhythmias and the patient will not receive ATP or shock defibrillation therapy until the pulse generator is programmed back to normal operation. Only scan the patient if judged to be clinically capable of tolerating no Tachycardia protection for the entire duration in which the pulse generator is in MRI Protection Mode.

Ventricular Detection Enhancement Suites

One of the following ventricular detection enhancement suites may be programmed to provide specificity beyond Rate and Duration (Table 2–3 Detection enhancement suites available per zone on page 2-8):

- Rhythm ID
- Onset/Stability

Detection enhancement suites are not available in the VF zone.

Table 2–3. Detection enhancement suites available per zone

	VT-1 Zone	VT Zone	VF Zone
3-zone configuration ^a	Rhythm ID Onset/Stability	Rhythm ID Onset/Stability ^d	None
3-zone configuration (with Monitor Only zone) ^{b c}	None	Rhythm ID Onset/Stability	None
2-zone configuration		Rhythm ID Onset/Stability	None
2-zone configuration (with Monitor Only zone) ^b		None	None
1-zone configuration			None

- If the detection enhancement suite is enabled in a 3-zone configuration, it applies to both the VT-1 and VT zones.
- Detection enhancement suites are not available in the lowest zone of a multi-zone configuration when the zone is used as a Monitor Only zone (no therapy programmed for that zone).
- For devices programmed to a 3 zone configuration with VT-1 programmed to Monitor Only and detection enhancements On in the VT zone, rhythm discrimination will be applied when a tachycardia meets Initial Detection in the Monitor Only zone and the rate subsequently accelerates to the VT zone. In this case, Initial Detection is restarted and detection enhancements are available in the VT zone.
- Shock if Unstable is the only Onset/Stability detection enhancement available in the VT zone of a 3-zone configuration (applies only to 3-zone configuration without a Monitor Only zone).

NOTE: *There is no clinical data to suggest that one detection enhancement suite is superior to the other for any given patient indication. Therefore, individual programming and evaluation of detection enhancement specificity is recommended.*

Rhythm ID

This feature is available in AUTOGEN, DYNAGEN, INOGEN, INCEPTA, ENERGEN, and COGNIS devices.

Rhythm ID uses Vector Timing and Correlation analysis in addition to atrial and ventricular interval analysis to determine if a patient's rhythm should be treated (VT) or if therapy should be inhibited (SVT).

With Rhythm ID, the pulse generator performs a vector timing and correlation analysis using the shock EGM and rate EGM. Based on this data, it saves a reference template of the patient's normal sinus rhythm.

During Rhythm ID analysis, the pulse generator first determines if the ventricular rate is greater than the atrial rate. If so, therapy will be initiated. If the ventricular rate is not greater than the atrial rate, Rhythm ID evaluates the following criteria to determine if therapy should be inhibited or initiated:

- Vector Timing and Correlation analysis during Initial Detection determines if the rhythm is SVT by comparing it to the previously stored reference template. If the rhythm is declared SVT, therapy is inhibited. For devices with RhythmMatch Threshold, the correlation between the patient's rhythm and the reference template must be equal to or greater than the programmed RhythmMatch Threshold for the rhythm to be declared SVT and therapy inhibited ("Vector Timing and Correlation" on page 2-22).
- If Vector Timing and Correlation does not declare the rhythm SVT, Stability and AFib Rate Threshold determine if the ventricular rhythm is unstable and the atrial rate is fast. If the ventricular rhythm is unstable and the atrial rate is fast, the rhythm is declared SVT and therapy is inhibited.

Rhythm ID does not consider atrial detection criteria (V Rate > A Rate or A greater than AFib Rate Threshold) for the following configurations:

- Dual-chamber devices if Atrial Tachyarrhythmia Discrimination is programmed to Off

When configured this way, Stability is not evaluated for Initial Detection. This may be useful in instances where atrial lead problems have occurred. For these configurations, therapy is inhibited at Initial Detection if the rhythm is declared SVT (based on Vector Timing and Correlation). Otherwise, therapy is initiated.

Two methods are available for the device to automatically acquire a Rhythm ID reference template: passive and active. The active method may be useful for patients who are frequently ventricular paced.

If the passive method is enabled, the pulse generator will attempt to collect the Rhythm ID reference template every two hours using the programmed brady settings. Updates start between 2 and 4 hours after the device has been removed from Storage mode.

If the active method is enabled and seven days have passed since the last successful collection of a reference template, then every 28 hours the device automatically analyzes the patient's intrinsic rhythm by adjusting the brady parameters. During a Rhythm ID active reference template update, the following will occur:

1. The device verifies that the patient is at rest (as measured by the accelerometer input).
2. The device enables a controlled pacing rate decrease to the programmed Rhythm ID Fallback LRL. During this fallback period, the following occurs:
 - The device temporarily switches the pacing mode to DDI, VDI, VVI, AAI, or Off (according to the programmed brady mode) and extends the AV Delay up to 400 ms.
 - Biventricular Trigger, Rate Smoothing, ATR, Rate Hysteresis, Rate Search Hysteresis, and dynamic programming (excluding dynamic VRP) are suspended. The pacing chamber is set to Biventricular; LV Offset is set to 0.
3. After the Fallback period, pacing parameters are restored to normal programmed parameters. Fallback periods occur no more than once per day and will typically last less than one minute.

A method for manually commanding the device to acquire a Rhythm ID reference template is also available.

NOTE: If Rhythm ID is not enabled, a manual reference template update can still be performed. Should an arrhythmia occur, this allows the device to perform Vector Timing and Correlation analysis and, for devices with RhythmMatch Threshold, record the measured RhythmMatch value of the arrhythmia in the episode data. However, the Vector Timing and Correlation analysis result will not be used to determine if the patient's rhythm is VT or SVT.

During a manual Rhythm ID reference template update, the pulse generator will perform the following tasks:

1. Enable a controlled rate decrease to the programmed Rhythm ID Fallback LRL. During the fallback period, the following occurs:
 - The device temporarily switches to the programmed Manual Rhythm ID Brady Mode and extends the AV Delay up to 400 ms.
 - Biventricular Trigger, Rate Smoothing, ATR, Rate Hysteresis, Rate Search Hysteresis, and dynamic programming (excluding dynamic VRP) are suspended. The pacing chamber is set to Biventricular; LV Offset is set to 0.
2. After the Fallback interval, pacing parameters are restored to normal programmed parameters. This process will typically last less than one minute.

NOTE: Rhythm ID Fallback LRL settings should be selected such that normal sinus rhythms are promoted (e.g., normal AV node conduction). Care must be used when selecting LRL less than 50 min^{-1} (rates that approach the patient's ventricular escape rates). Ventricular escape rhythms during Rhythm ID updates may result in inappropriate therapy decisions.

NOTE: An acquired Rhythm ID reference template will be used to perform Vector Timing and Correlation analysis until a newer reference template is acquired.

NOTE: A manual Rhythm ID reference template update should not be commanded immediately after shock therapy. It may take several minutes for irregularities in EGM morphology caused by the shock to subside.

Consider the following when using Rhythm ID:

- Rhythm ID determines whether therapy will be inhibited or not at the end of Duration. If the decision is to inhibit therapy, then Rhythm ID (including Vector Timing and Correlation, V Rate > A Rate, AFib Rate Threshold, and Stability) continues to be reevaluated beat-by-beat. Use of the Sustained Rate Duration (SRD) feature will limit inhibition of therapy by Rhythm ID to the length of the programmed SRD.
- Rhythm ID will not inhibit therapy in the VF zone. Programming the VF rate threshold lower than the rate of fast rhythms will prevent Rhythm ID from inhibiting therapy for those rhythms.
- Programming Atrial Tachyarrhythmia Discrimination to On prevents Rhythm ID from inhibiting therapy if the ventricular rate is faster than the atrial rate.
- If no Rhythm ID reference template has ever been acquired, Rhythm ID uses only Stability and AFib Rate Threshold to discriminate between VT and SVT, because Vector Timing and Correlation analysis cannot be performed. Furthermore, if Rhythm ID does not consider atrial detection criteria, and no reference template has been acquired, no detection enhancements will be evaluated during Initial Detection.

Onset/Stability

This feature is available in AUTOGEN, DYNAGEN, INOGEN, ORIGEN, INCEPTA, ENERGEN, PUNCTUA, and COGNIS devices.

The Onset/Stability detection enhancement suite analyzes the cardiac cycle intervals to determine if a patient's rhythm should be treated (VT) or if therapy should be inhibited (SVT).

Onset/Stability allows you to program detection enhancements by identifying the desired type of rhythm discrimination: atrial tachyarrhythmia, sinus tachycardia, or polymorphic VT (Table 2–4 Onset/Stability rhythm discrimination available per zone on page 2-10).

Table 2–4. Onset/Stability rhythm discrimination available per zone

	VT-1 Zone	VT Zone	VF Zone
3-zone Configuration	Atrial Tachyarrhythmia Sinus Tachycardia	Polymorphic VT ^a	None
3-zone Configuration (with Monitor Only zone) ^{b c}	None	Atrial Tachyarrhythmia Sinus Tachycardia Polymorphic VT ^a	None
2-zone Configuration		Atrial Tachyarrhythmia Sinus Tachycardia Polymorphic VT ^a	None

Table 2–4. Onset/Stability rhythm discrimination available per zone (continued)

	VT-1 Zone	VT Zone	VF Zone
2-zone Configuration (with Monitor Only zone) ^b		None	None
1-zone Configuration			None

- a. Polymorphic VT Discrimination is only available in the VT zone.
- b. Rhythm discrimination is not available in the lowest zone of a multi-zone configuration if the zone is used as a Monitor Only zone (no therapy programmed for that zone).
- c. For devices programmed to a 3 zone configuration with VT-1 programmed to Monitor Only and detection enhancements On in the VT zone, rhythm discrimination will be applied when a tachycardia meets Initial Detection in the Monitor Only zone and the rate subsequently accelerates to the VT zone. In this case, Initial Detection is restarted and detection enhancements are available in the VT zone.

Reconfirmation/Committed Shock

Reconfirmation refers to the monitoring performed by the device during and immediately following capacitor charging for a shock. When the Committed Shock parameter is programmed to Off, the device is allowed to reconfirm that a shock should be delivered.

Ventricular Redetection

This feature is available in AUTOGEN, DYNAGEN, INOGEN, ORIGEN, INCEPTA, ENERGEN, PUNCTUA, and COGNIS devices.

Ventricular Redetection occurs following any:

- Ventricular therapy delivery
- Diverted therapy due to reconfirmation analysis (diverted-reconfirm)
- Manually diverted therapy
- Therapy not available at Detection Met (except when the VT-1 zone is programmed to Monitor Only, in which case Initial Detection is restarted)

Redetection uses the same ventricular detection window process and programmed tachycardia Rate thresholds as Initial Detection to identify a tachyarrhythmia.

The primary differences between Initial Detection and Redetection are the Duration parameters used and the detection enhancements that are available:

- If ventricular shock therapy is delivered, the following will occur:
 - The redetection duration time is determined by the value of the Post-shock Duration parameter
 - Detection enhancements (except for Onset, Shock if Unstable, and Vector Timing and Correlation) are available during redetection
- If ventricular ATP is delivered or if therapy is diverted or unavailable, the following will occur:
 - The redetection duration time is determined by the Redetection Duration parameter
 - Detection enhancements (except for Shock if Unstable) are not available during redetection

Whichever duration is determined to be appropriate, that type of duration (Redetection or Post-Shock) will be in effect in all zones at each zone's programmed duration value.

Ventricular Post-shock Detection Enhancements

When programmed to On, the following ventricular post-shock detection enhancements will be in effect following the Post-shock Duration:

- Post-shock V Rate > A Rate
- Post-Shock AFib Rate Threshold
- Post-shock Stability
- Post-shock SRD
- Post-shock Rhythm ID (uses AFib Rate Threshold, Stability, V Rate > A Rate, and SRD)

With the exception of Rhythm ID, all post-shock detection enhancements perform the same as the corresponding Initial Detection enhancements (with Rhythm ID, Vector Timing and Correlation is not available post-shock).

Post-shock Stability may be used to prevent shock-induced AF from causing the pulse generator to deliver undesired additional shocks (Figure 2–2 Post-shock Duration and Post-shock Stability analysis on page 2-12.)

The AFib Rate Threshold can be programmed in conjunction with Post-shock Stability to further discriminate AF and prevent the pulse generator from delivering undesired ventricular shock therapy.

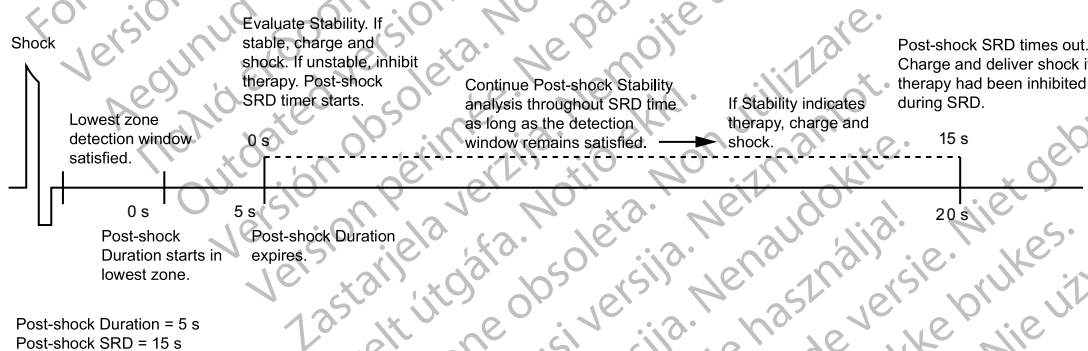

Figure 2–2. Post-shock Duration and Post-shock Stability analysis

Ventricular Detection Details

This feature is available in AUTOGEN, DYNAGEN, INOGEN, ORIGEN, INCEPTA, ENERGEN, PUNCTUA, and COGNIS devices.

The pulse generator uses the following information to determine appropriate therapy delivery:

- Ventricular detection windows
- Duration parameter
- Redetection duration and post-shock duration
- Ventricular episodes
- Ventricular detection enhancements

Ventricular Detection Windows

Appropriate therapy delivery is dependent upon accurately classifying a patient's rhythm. To ensure that appropriate therapy is delivered, the pulse generator employs detection windows to differentiate tachycardias.

Each ventricular zone has a detection window that consists of the 10 most recent RV R–R intervals measured by the pulse generator. As each new interval is measured, it is compared to each zone’s programmed rate threshold and classified as either fast or slow (i.e., above or below the rate threshold) in each detection window.

The pulse generator prepares for a potential episode when it counts 3 consecutive fast intervals. The detection window is satisfied and an episode is declared when 8 out of 10 fast intervals are counted. The detection window will remain satisfied as long as 6 of 10 intervals remain classified as fast. If the number of fast intervals falls below 6, the zone’s detection window is no longer satisfied. The zone’s detection window will only become resatisfied when 8 of 10 intervals are again classified as fast (Figure 2–3 Ventricular detection window satisfied on page 2-13).

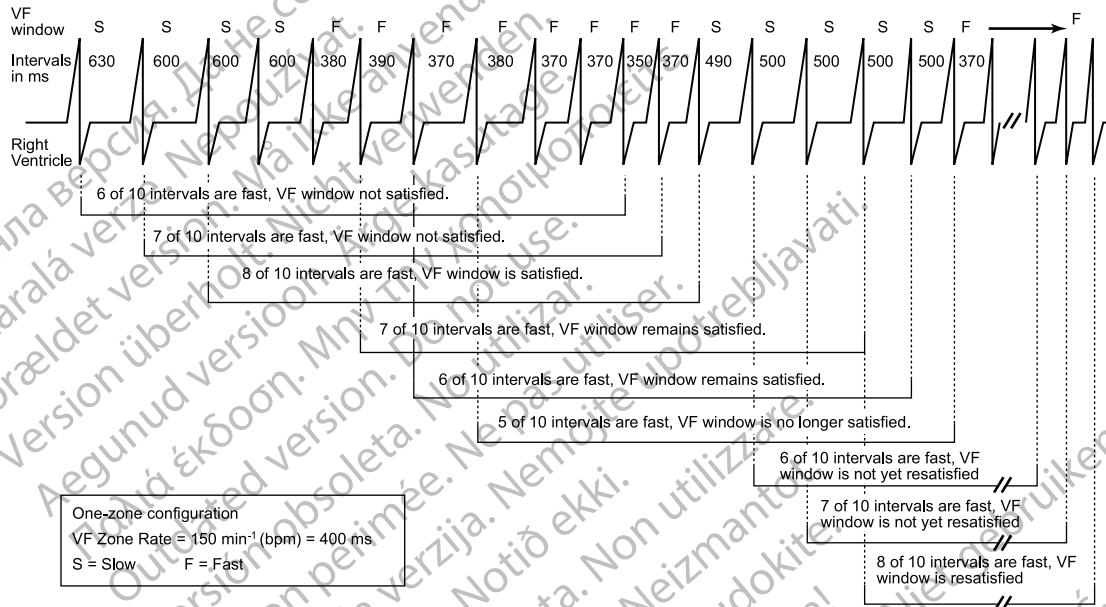

Figure 2–3. Ventricular detection window satisfied

Because Rate Threshold in the higher zones must be programmed at a value greater than Rate Threshold in lower zones, an interval classified as fast in a higher window would also be classified as fast in any lower windows (Figure 2–4 Interaction of ventricular detection windows, 2-zone configuration on page 2-13).

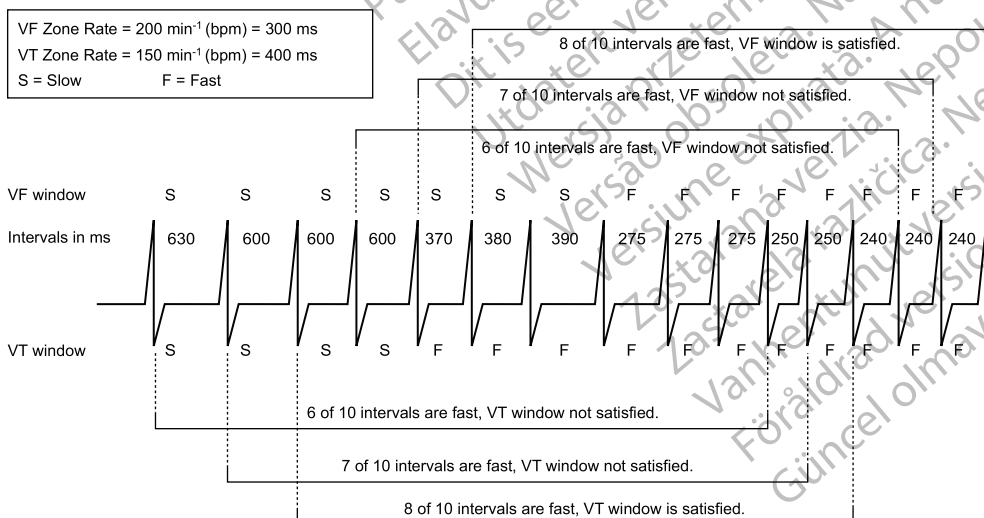

Figure 2–4. Interaction of ventricular detection windows, 2-zone configuration

Duration Parameter

The Duration parameter is a timer that measures the length of time in each zone that a rhythm must be sustained before therapy is delivered.

A Duration timer begins when its respective zone's detection window is satisfied. The programmed Duration time is checked following every cardiac cycle to determine if it has expired.

NOTE: Since the Duration timer is examined synchronously with a cardiac cycle, the programmed Duration may be exceeded by up to one full cardiac cycle.

- As long as the zone's detection window remains satisfied, the Duration timer continues to elapse. If the last detected interval is in the zone when its Duration time expires, detection is considered met and therapy is initiated (assuming no programmed detection enhancements inhibit therapy delivery) (Figure 2-5 Ventricular Duration timer on page 2-14).
- If the last detected interval is not in the zone, therapy is not initiated. Each subsequent interval will be checked until an interval is in the original zone, or the window is no longer satisfied (Figure 2-6 Last detected interval on page 2-14).
- If at any point during Duration a zone's detection window detects fewer than 6 of 10 fast intervals, that zone's Duration is reset to 0 (Figure 2-7 Ventricular Duration reset on page 2-15). Duration will start again only if the detection window becomes resatisfied.

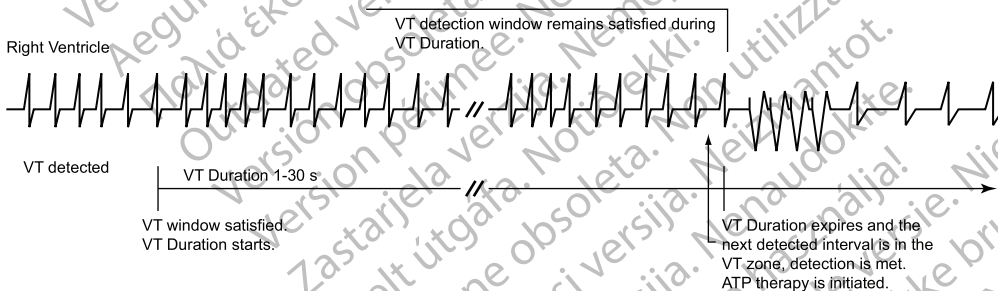

Duration starts when a window becomes satisfied and continues to elapse as long as the ventricular detection window remains satisfied. Detection is met when Duration expires and the next detected interval is in the same ventricular zone.

Figure 2-5. Ventricular Duration timer

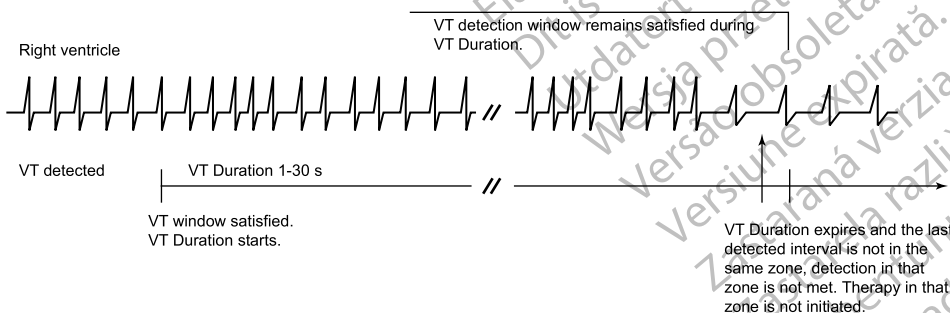
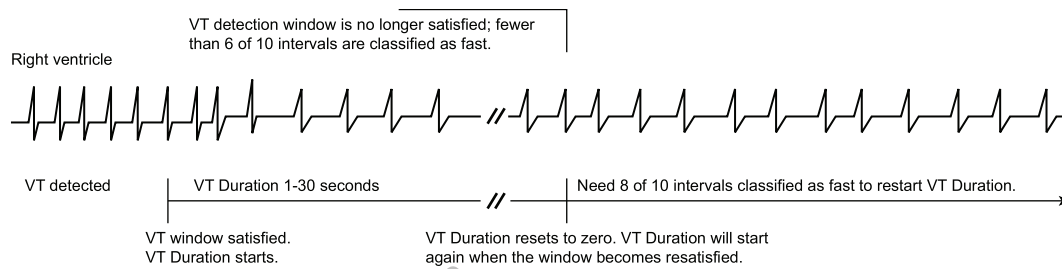

Figure 2-6. Last detected interval



Duration resets when during the Duration period the window is no longer satisfied.

Figure 2-7. Ventricular Duration reset

A Duration is programmed for each ventricular zone. Different values are available depending on the configuration programmed (Table 2-5 Duration programmable ranges by ventricular zone and configuration on page 2-15). The Duration programmed in lower ventricular rate zones must be greater than or equal to higher ventricular zones. Longer Durations may be used to prevent the device from initiating treatment of non-sustained arrhythmias.

Table 2-5. Duration programmable ranges by ventricular zone and configuration

Configuration	VT-1 Zone ^a	VT Zone ^a	VF Zone ^b
1 Zone	--	--	1–15 seconds
2 Zones	--	1–30 seconds	1–15 seconds
3 Zones	1–60 seconds	1–30 seconds	1–15 seconds

a. The maximum redetect duration for the VT-1 and VT zones is 15 seconds.

b. In the VF zone, the redetect and post-shock duration is fixed at 1 second.

Duration in a Multi-zone Configuration

Duration timers run independently of each other within their respective ventricular zones.

- If the arrhythmia is detected in the highest zone, that zone's Duration timer takes precedence over the lower zones' timers; the lower zones' Duration timers continue to elapse but are ignored while the higher zone's Duration timer runs.
- If the higher zone's Duration expires and detection is met, therapy for that zone will be initiated regardless of whether the lower zones' Duration timers have expired.
- If the higher zone's detection window does not remain satisfied, then the Duration timers for the lower ventricular zones are no longer ignored.

Programmed therapy for lower ventricular zones will be initiated when a lower ventricular zone's duration is met and no higher ventricular zone's window is satisfied (Figure 2-8 Interaction of ventricular Duration, 2-zone configuration, charging on page 2-16, Figure 2-9 Interaction of ventricular Duration, 2-zone configuration, charging delayed on page 2-16).

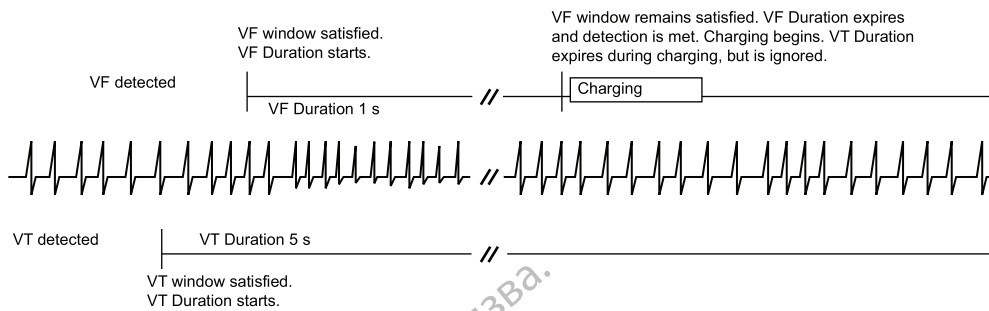

Figure 2-8. Interaction of ventricular Duration, 2-zone configuration, charging

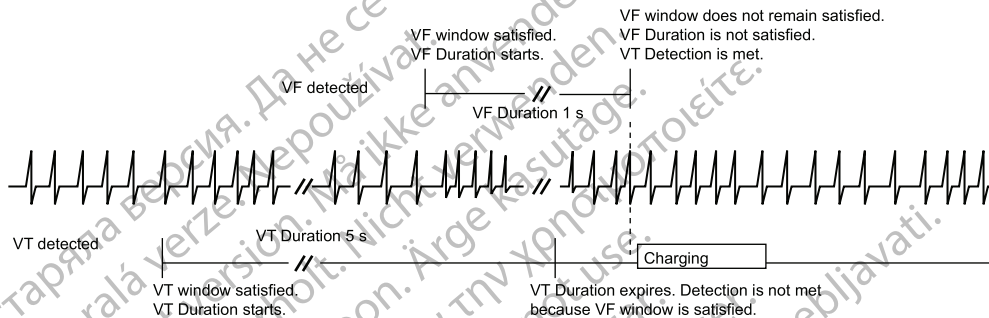

Figure 2-9. Interaction of ventricular Duration, 2-zone configuration, charging delayed

Ventricular Redetection Duration and Post-shock Duration

Duration parameters are used to identify tachyarrhythmias during the ventricular redetection process.

- Redetection Duration is applied following delivery of ATP therapy (except QUICK CONVERT ATP), a diverted-reconfirm, manually diverted therapy, or if therapy is unavailable at Detection Met (Figure 2-10 Redetection following ventricular ATP delivery on page 2-17).
- Post-shock Duration is applied following shock therapy delivery (Figure 2-11 Redetection following ventricular shock delivery on page 2-17).

Redetection Duration is programmable in the lower ventricular zones of a multi-zone configuration. It is nonprogrammable in the VF Zone. Post-shock Duration can be programmed in the same manner; the values programmed in the lower ventricular rate zones must be greater than or equal to the values programmed in the higher zones.

To help minimize time to potential therapy, it is recommended that Redetection Duration in the VT-1 and VT zones of multi-zone configurations be programmed at less than or equal to 5 seconds.

It is recommended that Post-shock Duration in the VT-1 and VT zones of multi-zone configurations also be programmed at less than or equal to 5 seconds. However, you may program for longer durations if shock-induced, non-sustained, high-rate rhythms, such as accelerated idioventricular rhythm (AIVR) or AF are evident. The longer durations may allow the rhythm to return to a lower rate before redetection is met.

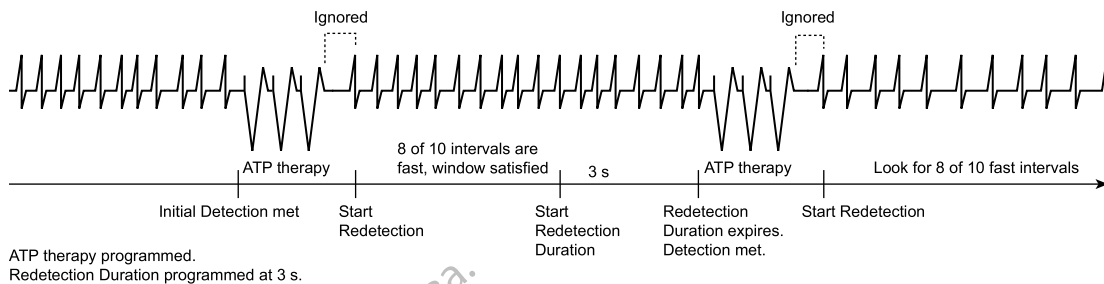

Figure 2-10. Redetection following ventricular ATP delivery

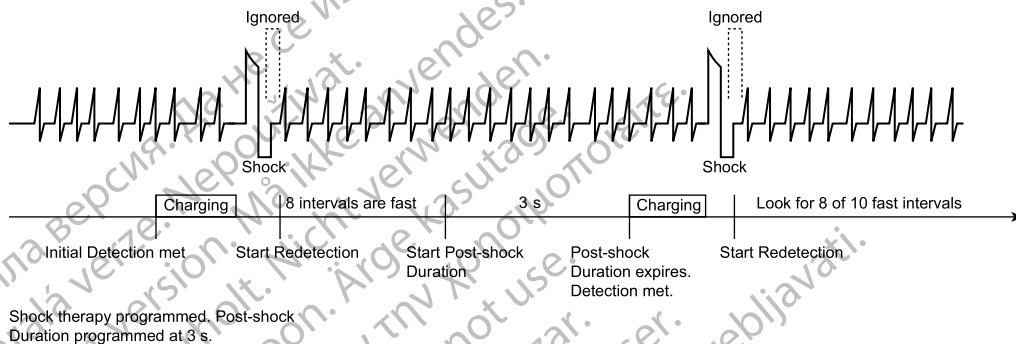

Figure 2-11. Redetection following ventricular shock delivery

Ventricular Episodes

For AUTOGEN, DYNAGEN, INOGEN, and ORIGEN devices, if three consecutive fast ventricular beats are detected, then the pulse generator starts monitoring for a detection window to be satisfied. When any zone's detection window becomes satisfied, the pulse generator performs the following:

- Declares the start of a ventricular episode
- Increments the episode number
- Allocates memory for history data and electrogram storage
- Begins duration timers in zones where detection windows are satisfied

The ventricular episode is declared complete when all detection windows are no longer satisfied and remain unsatisfied for a specified time.

For INCEPTA, ENERGEN, PUNCTUA, and COGNIS devices, if three consecutive fast ventricular beats are detected, then the pulse generator performs the following:

- Increments the episode number
- Allocates memory for history data and electrogram storage
- Starts monitoring for a detection window to be satisfied

When any zone's detection window becomes satisfied, the start of a ventricular episode is declared and duration timers begin in those zones where detection windows are satisfied. The ventricular episode is declared complete when all detection windows are no longer satisfied and remain unsatisfied for a specified time.

For all devices, each ventricular tachy episode is classified as Treated or Non-Treated (Figure 2-12 Treated episode, ventricular mode is Monitor + Therapy and ATP is delivered on page 2-18 through Figure 2-16 Treated episode, ventricular mode is Monitor + Therapy and End-of-Episode timer is reset to 0 on page 2-19).

- A Treated episode is one in which therapy is delivered
- A Non-Treated episode is one in which no therapy is delivered

For a Treated episode, an End-of-Episode timer starts after therapy is delivered. For a Non-Treated episode, an End-of-Episode timer starts at the point that the pulse generator recognizes that all detection windows are no longer satisfied. The End-of-Episode time interval is intended to allow the patient to stabilize before Initial Detection and initial therapy are used again. The episode is declared complete if no detection window becomes satisfied for a specified time following the last therapy attempt (Table 2–6 End-of-Episode Timer on page 2-18). If any window becomes satisfied while the End-of-Episode timer is elapsing, the End-of-Episode timer is reset to zero. It will start again when either therapy is attempted or all windows are not satisfied (Figure 2–16 Treated episode, ventricular mode is Monitor + Therapy and End-of-Episode timer is reset to 0 on page 2-19).

Once an episode has been declared complete, the pulse generator will apply Initial Detection and therapy to subsequent tachyarrhythmias.

Table 2–6. End-of-Episode Timer

Episode Classification	Ventricular End-of-Episode Timer (elapsed time required to declare episode over)
Non-Treated (no therapy delivered)	10 seconds
Treated (only ATP therapy delivered)	10 seconds
Treated (any shock therapy delivered)	30 seconds

NOTE: The episode is terminated immediately if the Tachy Mode is reprogrammed, an induction method or lead test is attempted before the End-of-Episode time out, or any ventricular detection or ventricular therapy parameters are reprogrammed.

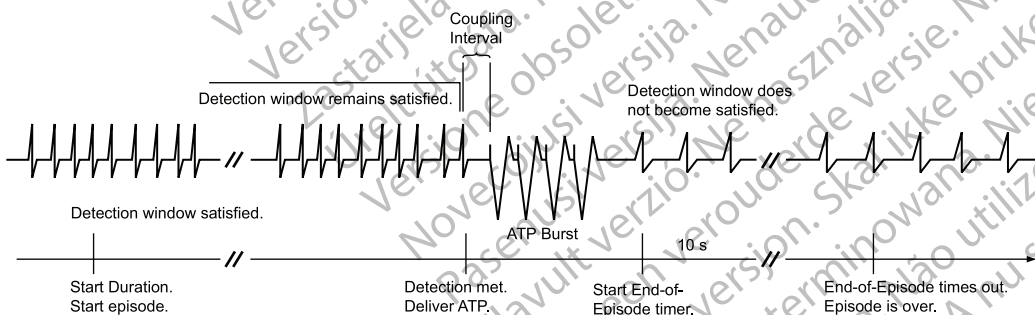

Figure 2–12. Treated episode, ventricular mode is Monitor + Therapy and ATP is delivered

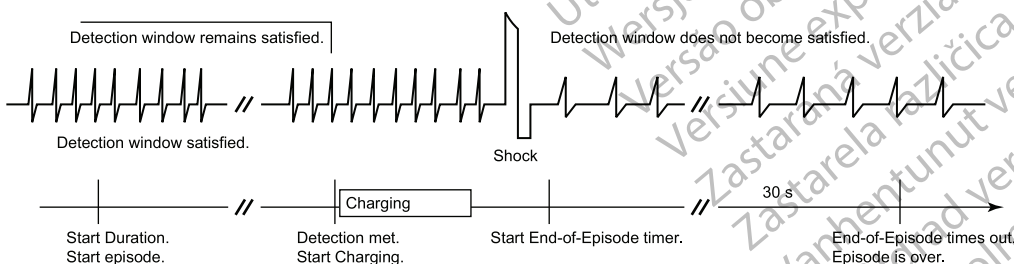

Figure 2–13. Treated episode, ventricular mode is Monitor + Therapy and shock is delivered

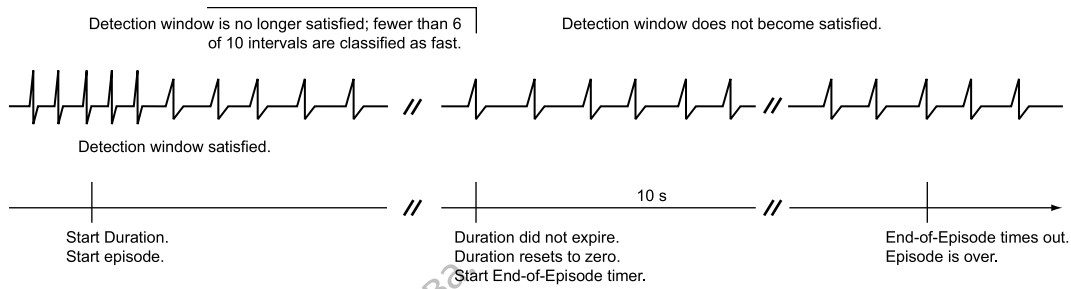
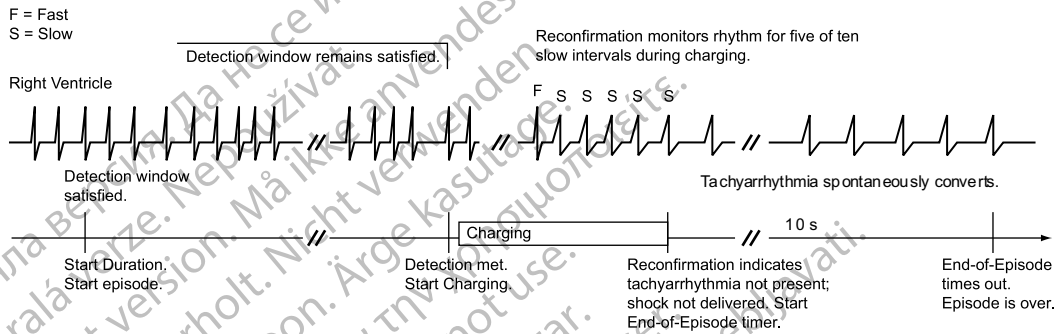
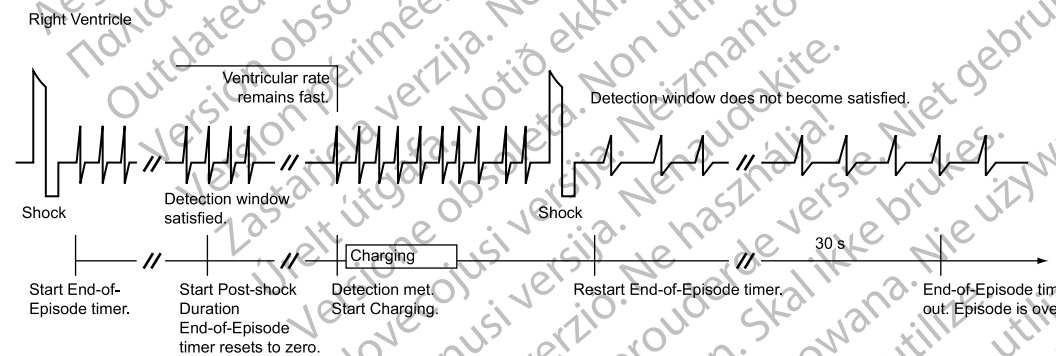

Figure 2-14. Non-Treated episode, ventricular mode is Monitor + Therapy or Monitor Only, duration is not expired



This example assumes Committed Shock is programmed to Off.

Figure 2-15. Non-Treated episode, ventricular mode is Monitor + Therapy and charging is stopped prior to shock delivery



This example illustrates a Treated Episode when Ventricular Mode is Monitor + Therapy. The End-of-Episode timer is reset to 0 when a ventricular detection window becomes satisfied after ventricular therapy delivery, but prior to the episode time-out being reached. In this example, 2 shocks were delivered in the episode.

Figure 2-16. Treated episode, ventricular mode is Monitor + Therapy and End-of-Episode timer is reset to 0

Ventricular Detection Enhancements

Ventricular detection enhancements add specificity to the Rate and Duration detection criteria. You may program ventricular detection enhancements to perform the following:

- Delay or inhibit therapy delivery
- Override therapy inhibition
- Bypass a sequence of ATP therapy in favor of shock therapy

Ventricular detection enhancements may be programmed to one of the following:

- Rhythm ID

- Onset/Stability
- Off (i.e., Rate Only)

If Off is selected, only the ventricular rate and duration are used for therapy decisions.

If either Rhythm ID or Onset/Stability is selected, enhancement parameters are used in addition to ventricular Rate and Duration for therapy decisions (Table 2–7 Enhancement parameters available with detection enhancements on page 2-20) as follows:

- Vector Timing and Correlation inhibits therapy when the conduction vector (EGM morphology and timing) during tachyarrhythmia matches a reference conduction vector of the patient's normal sinus rhythm.
- V Rate > A Rate can be used to override the inhibit decision of Onset, Stability, Vector Timing and Correlation, and/or AFib Rate Threshold. V Rate > A Rate can be used to deliver ventricular therapy anytime the ventricular rate is greater than the atrial rate.
- AFib Rate Threshold can be programmed (together with stability) to inhibit ventricular therapy if the atrial rhythm is fast.
- Stability can be programmed to inhibit ventricular therapy delivery if the ventricular rhythm is unstable.
- Shock if Unstable can be programmed to bypass the ventricular ATP therapy and deliver shock therapy if the ventricular rhythm is declared Unstable.
- Onset can be programmed to inhibit ventricular therapy if the patient's heart rate increases gradually.
- SRD enables the pulse generator to override the Stability, Onset, Vector Timing and Correlation, and/or AFib Rate Threshold parameters' decision to inhibit ventricular therapy if the high rate continues throughout the programmed time period.

Table 2–7. Enhancement parameters available with detection enhancements

Enhancement Parameter	Rhythm ID		Onset/Stability	
	Initial	Post-Shock	Initial	Post-Shock
Vector Timing and Correlation ^a	X	--	--	--
V Rate > A Rate (dual-chamber devices only)	X ^{b c}	X ^{b c}	X	X
AFib Rate Threshold (dual-chamber devices only)	X ^{b d}	X ^{b d}	X ^e	X ^e
Stability (to inhibit)	X ^f	X ^f	X	X
Shock if Unstable	--	--	X	--
Onset	--	--	X	--
SRD ^g	X	X	X	X

- This enhancement is not individually programmable.
- When Rhythm ID is selected, this enhancement is automatically enabled when Atrial Tachyarrhythmia Discrimination is programmed to On. However, it is not available in single chamber devices or when the Atrial Tachyarrhythmia Discrimination is programmed to Off in dual chamber devices.
- This enhancement is not individually programmable when Rhythm ID is enabled.
- When Rhythm ID is selected, this parameter uses the same value for both Initial and Post-Shock Detection. It cannot be independently enabled or disabled for Post-Shock Detection.
- When Onset/Stability is selected, this parameter can be enabled and disabled independently for Post-Shock Detection. If enabled, it uses the same value as the Initial Detection.
- When Rhythm ID is enabled and Atrial Tachyarrhythmia Discrimination is programmed to On in dual chamber devices, this enhancement uses the same value for both Initial and Post-Shock Detection. In single chamber devices, or when Atrial Tachyarrhythmia Discrimination is programmed to Off, this enhancement is automatically disabled for Initial Detection, but is still enabled for Post-Shock Detection.
- SRD is available when detection enhancements, which inhibit therapy, are programmed.

Some of these detection enhancement parameters are also independently programmable as Post-Shock parameters (Table 2–7 Enhancement parameters available with detection enhancements on page 2-20).

The individual detection enhancement parameters that are available depend on the number of tachy zones that are programmed: 3, 2, or 1 (Table 2–8 Individual Ventricular Detection Enhancements available in multizone configurations on page 2-21).

Table 2–8. Individual Ventricular Detection Enhancements available in multizone configurations

	VT-1 Zone	VT Zone	VF Zone
3-zone configuration	Vector Timing and Correlation V Rate > A Rate AFib Rate Threshold Stability (to Inhibit) Onset SRD	Vector Timing and Correlation ^a V Rate > A Rate ^a AFib Rate Threshold ^a Stability (to Inhibit) ^a Shock if Unstable SRD ^a	--
3-zone configuration (with Monitor Only zone) ^{b, c}	--	Vector Timing and Correlation V Rate > A Rate AFib Rate Threshold Stability (to Inhibit) Shock if Unstable ^d Onset SRD	--
2-zone configuration		Vector Timing and Correlation V Rate > A Rate AFib Rate Threshold Stability (to Inhibit) Shock if Unstable ^d Onset SRD	--
2-zone configuration (with Monitor Only zone) ^b		--	--
1-zone configuration			--

- a. Enhancement is available in the middle zone of a 3-zone configuration only when Rhythm ID is enabled.
- b. Detection enhancements are not available in the lowest zone of a multi-zone configuration when it is used as a Monitor Only zone (no therapy programmed for that zone).
- c. For devices programmed to a 3 zone configuration with VT-1 programmed to Monitor Only and detection enhancements On in the VT zone, rhythm discrimination will be applied when a tachycardia meets Initial Detection in the Monitor Only zone and the rate subsequently accelerates to the VT zone. In this case, Initial Detection is restarted and detection enhancements are available in the VT zone.
- d. Shock if Unstable cannot be programmed on in the same zone as other detection enhancements that are programmed to inhibit therapy (Onset, Stability, and AFib Rate Threshold).

When a specific rhythm discrimination is selected, you can modify the values for the detection enhancements that are suitable for discriminating that rhythm. Nominal values are shown in the following table; however, you can use those values at your discretion.

Table 2–9. Nominal values for initial detection and redetection enhancements

Parameter	Onset/Stability			Rhythm ID	
	Atrial Tachyarrhythmia Discrimination	Sinus Tachycardia Discrimination	Polymorphic VT Discrimination	Atrial Tachyarrhythmia Discrimination On	Atrial Tachyarrhythmia Discrimination Off
Vector Timing and Correlation	--	—	—	On ^a	On ^a
V Rate > A Rate (dual-chamber models only)	On	On	--	On ^b	--
AFib Rate Threshold (dual-chamber models only)	170 min ⁻¹	--	--	170 min ⁻¹	--
Stability (Inhibit)	20 ms	--	--	20 ms	30 ms
Onset (Initial Detection only)	--	9%	--	--	--

Table 2-9. Nominal values for initial detection and redetection enhancements (continued)

Parameter	Onset/Stability			Rhythm ID	
	Atrial Tachyarrhythmia Discrimination	Sinus Tachycardia Discrimination	Polymorphic VT Discrimination	Atrial Tachyarrhythmia Discrimination On	Atrial Tachyarrhythmia Discrimination Off
SRD Initial	3:00 minutes: seconds	3:00 minutes: seconds	--	3:00 minutes: seconds	3:00 minutes: seconds
SRD Redetection	0:15 minutes: seconds	--	--	0:15 minutes: seconds	0:15 minutes: seconds
Shock if Unstable	--	--	30 ms	--	--

- a. Parameter is not individually programmable.
- b. Parameter is not individually programmable when Rhythm ID is enabled.

Vector Timing and Correlation

This feature is available in AUTOGEN, DYNAGEN, INOGEN, INCEPTA, ENERGEN, and COGNIS devices.

Vector Timing and Correlation compares EGM signals for an unknown rhythm with a stored reference template of the EGM signals of a normal sinus rhythm (NSR). Rhythms that are not similar (i.e. not correlated) to the stored reference template are classified as VT. Rhythms that are correlated with the stored reference template are classified as SVT. Rhythm ID uses this classification during Initial Detection to make a decision to treat or to inhibit therapy.

When a fast rhythm is sensed, each beat of the rhythm is compared to the stored reference template. The pulse generator measures the correlation of the detected waveform to the stored reference template, and classifies each beat as correlated or uncorrelated. A beat in the VF zone is always counted as uncorrelated, even if it has a high measured correlation value.

The pulse generator then classifies the detected rhythm as SVT or VT based on the calculations:

- If at least 3 out of 10 beats are correlated, the rhythm is classified as SVT, shown as RID+ in the annotated electrograms
- If fewer than 3 out of 10 beats are correlated, the rhythm is classified as VT, shown as RID- in the annotated electrograms

RhythmMatch Threshold

This feature is available in AUTOGEN, DYNAGEN, and INCEPTA devices.

Programming the RhythmMatch Threshold parameter will adjust the threshold used by Vector Timing and Correlation to determine whether a patient's rhythm correlates to their normal sinus rhythm template. By adjusting the RhythmMatch Threshold, you can adjust how the pulse generator discriminates between VT and SVT.

The RhythmMatch Threshold is programmable between 70% and 96%, with a nominal value of 94%. During Vector Timing and Correlation analysis, the pulse generator uses the programmed RhythmMatch Threshold as the criteria for classifying the patient's rhythm as either VT or SVT ("Vector Timing and Correlation" on page 2-22).

The pulse generator records a RhythmMatch score for the detected rhythm based on the calculated correlation values used to classify the rhythm as VT or SVT. Up to two measured RhythmMatch values may be recorded: one if and when therapy is first inhibited (by Rhythm ID), and one if and when therapy is attempted. The measured RhythmMatch values are recorded even if Rhythm ID is not enabled, as long as a reference template has been acquired.

If Rhythm ID is enabled, each beat's measured correlation value, as well as an indication of whether the beat was classified as correlated or uncorrelated, is recorded in the stored electrograms during Initial Detection. These measured correlation values may be helpful in determining the best RhythmMatch Threshold value to program for the patient. In addition, measured correlation values for VF beats may be helpful in programming the VF zone rate threshold.

NOTE: Under certain circumstances, the recorded correlation data for some individual beats may not be displayed on the programmer screen.

NOTE: When the memory allocated to EGM storage is full, the device overwrites older EGM data segments in order to store new EGM data. Events must be saved in order to preserve the calculated RhythmMatch values and the measured beat-to-beat correlation values for future reference.

When reprogramming the RhythmMatch Threshold value, consider the following:

- Review the measured RhythmMatch values for previous episodes of VT and SVT (induced or spontaneous)
- To increase the likelihood of appropriate treatment of VT, the RhythmMatch Threshold should be programmed above the measured RhythmMatch values of any VTs
- To increase the likelihood of appropriate inhibition of therapy for SVT, the RhythmMatch Threshold should be programmed below the measured RhythmMatch values of any SVTs
- In general, the sensitivity of VT detection declines with lower programmed RhythmMatch Threshold values, therefore for maximum sensitivity to VT, the highest appropriate RhythmMatch Threshold value should be programmed.
- Measured RhythmMatch values may also be useful for programming other Rhythm ID parameters including Atrial Tachyarrhythmia Discrimination, AFib Rate Threshold, and Stability
- By decreasing the RhythmMatch Threshold, the following will occur (Figure 2–17 Programming the RhythmMatch threshold on page 2-24):
 - The patient's rhythm is more likely to correlate to the stored reference template
 - The pulse generator will be less sensitive to VT
 - The pulse generator will be more likely to classify the rhythm as SVT and inhibit therapy
 - If the RhythmMatch Threshold is programmed too low, VT could go untreated
- By increasing the RhythmMatch Threshold, the following will occur (Figure 2–17 Programming the RhythmMatch threshold on page 2-24):
 - The patient's rhythm is less likely to correlate to the stored reference template
 - The pulse generator will be more sensitive to VT
 - The pulse generator will be less likely to classify the rhythm as SVT and inhibit therapy
 - If the RhythmMatch Threshold is programmed too high, therapy may not be inhibited for SVT episodes

Therefore, it is important to review past episodes of VT and SVT and determine what RhythmMatch Threshold is sufficiently above the patient's correlation values for VT, but still

below the correlation values for SVT. This may allow the pulse generator to more accurately distinguish between VT and SVT, and potentially reduce delivery of inappropriate therapy.



[1] Nominal RhythmMatch Threshold value [2] Less sensitive to VT, more specific for SVT [3] More sensitive to VT, less specific for SVT

Figure 2-17. Programming the RhythmMatch threshold

See Figure 2-18 Relationship between sensitivity and specificity using RhythmMatch Threshold on page 2-24 for an illustration of the relationship between sensitivity and specificity to VT at the population level as the RhythmMatch Threshold value is increased or decreased (RhythmMatch Threshold is programmable between 70% and 96%, with a nominal value of 94%). In general, as the RhythmMatch Threshold is increased, sensitivity to VT increases, and specificity for SVT decreases. As the RhythmMatch Threshold is decreased, sensitivity to VT decreases, and specificity for SVT increases. This relationship can also be stated as follows: at higher programmed RhythmMatch Threshold values, an arrhythmia is more likely to be classified as VT and less likely to be classified as SVT, while at lower programmed RhythmMatch Threshold values, an arrhythmia is more likely to be classified as SVT and less likely to be classified as VT.

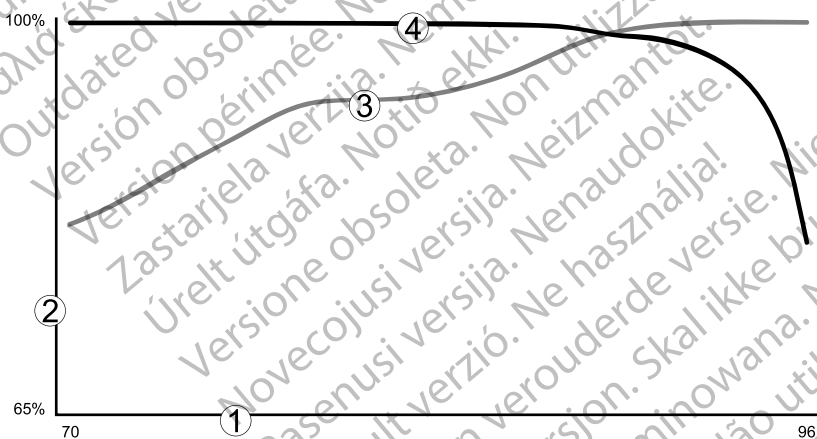

[1] Programmed RhythmMatch Threshold (%) [2] Sensitivity or specificity percentage [3] Sensitivity to VT [4] Specificity for SVT

Figure 2-18. Relationship between sensitivity and specificity using RhythmMatch Threshold

V Rate > A Rate

This feature is available in AUTOGEN, DYNAGEN, INOGEN, ORIGEN, INCEPTA, ENERGEN, PUNCTUA, and COGNIS devices.

The V Rate > A Rate (ventricular rate greater than atrial rate) enhancement compares the atrial and ventricular rates to classify the type of fast ventricular rhythm. When the ventricular rate is greater than the atrial rate, therapy will be initiated regardless of the analysis of the other programmed detection enhancements.

Analysis is made by comparing the average rate of the last 10 ventricular intervals prior to the end of Duration to the average rate of the last 10 atrial intervals prior to the end of Duration (Figure 2-19 V Rate > A Rate analysis on page 2-25). If fewer than 10 atrial intervals are

available, those intervals will be used to calculate the average atrial rate. This analysis is performed using the following criteria:

- If the average ventricular rate is greater than the average atrial rate by at least 10 min^{-1} , the ventricular rate is declared to be faster than the atrial rate (indicated as True on the Episode Detail Report), and therapy will be initiated.
- If the average ventricular rate is not greater than the average atrial rate by at least 10 min^{-1} (indicated as False on the Episode Detail Report), therapy may continue to be inhibited. The Episode Detail Report will indicate the measured value even though the parameter may be programmed to Off.

If therapy is inhibited, the $V \text{ Rate} > A \text{ Rate}$ analysis continues until either the ventricular rate is greater than the atrial rate or other enhancements indicate therapy treatment, at which time therapy will be initiated.

NOTE: $V \text{ Rate} > A \text{ Rate}$ is not evaluated during redetection following ATP therapy.

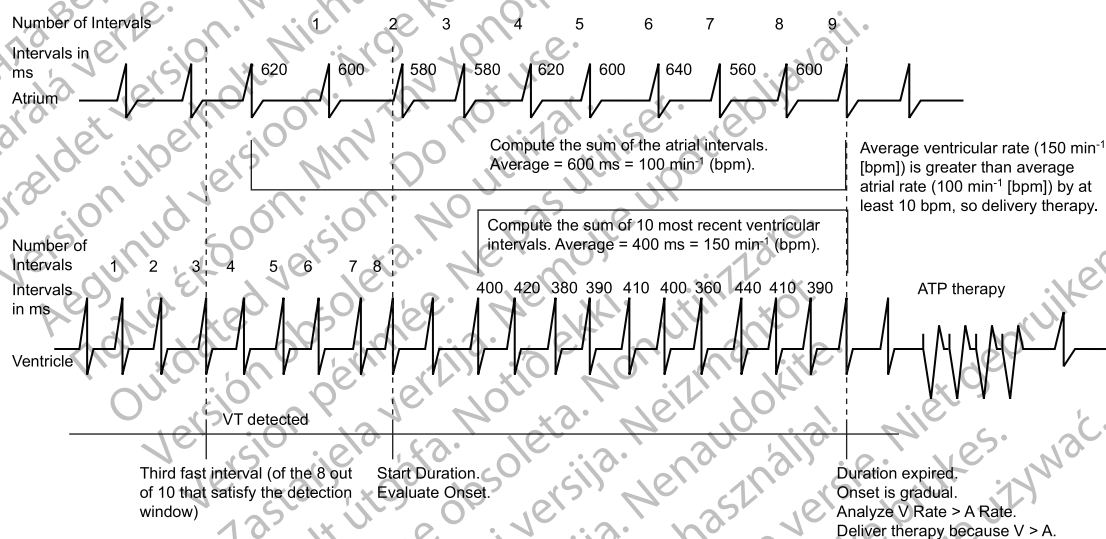

Figure 2-19. V Rate > A Rate analysis

$V \text{ Rate} > A \text{ Rate}$ can be programmed to bypass inhibitors (Vector Timing and Correlation, AFib Rate Threshold, Stability, and/or Onset) and initiate therapy in the event that the ventricular rate is faster than the atrial rate.

NOTE: Refer to "Use of Atrial Information" on page 2-6 for additional information about device performance when the atrial lead is programmed to Off.

NOTE: In a Rhythm ID configuration, the evaluation of $V \text{ Rate} > A \text{ Rate}$ is linked to the AFib Rate Threshold. If Atrial Tachyarrhythmia Discrimination is programmed to Off, the AFib Rate Threshold and $V \text{ Rate} > A \text{ Rate}$ detection enhancements are not evaluated.

AFib Rate Threshold

This feature is available in AUTOGEN, DYNAGEN, INOGEN, ORIGEN, INCEPTA, ENERGEN, PUNCTUA, and COGNIS devices.

AFib Rate Threshold analysis identifies AF by comparing the atrial rate to the programmed AFib Rate Threshold.

AFib Rate Threshold cannot be enabled without also enabling the Stability detection enhancement. The device analyzes both parameters to determine whether to withhold or deliver therapy.

If the intrinsic atrial rate is greater than the AFib Rate Threshold and the ventricular rhythm is classified as Unstable, the ventricular rhythm is declared to be due to AF.

The intrinsic atrial rate is declared to be above the AFib Rate Threshold in the following manner (Figure 2–20 Interaction of AFib Rate Threshold and Stability on page 2-26):

- Atrial analysis begins at initiation of ventricular tachyarrhythmia detection. Each atrial interval is classified as faster or slower than the AFib Rate Threshold Interval.
- When 6 of the last 10 intervals are classified as faster than the AFib Rate Threshold, the device declares AF to be present.
- Ventricular stability is then checked. If unstable, therapy is inhibited.

In the event that ventricular therapy is not delivered, the atrial rate continues to be examined. As long as 4 of 10 intervals remain classified as fast, AF is considered present. Therapy is inhibited by AFib Rate Threshold/Stability until any of the following occur:

- The atrial rate drops below the AFib Rate Threshold
- The ventricular rhythm becomes stable
- If programmed to On, $V \text{ Rate} > A \text{ Rate}$ is true
- SRD times out

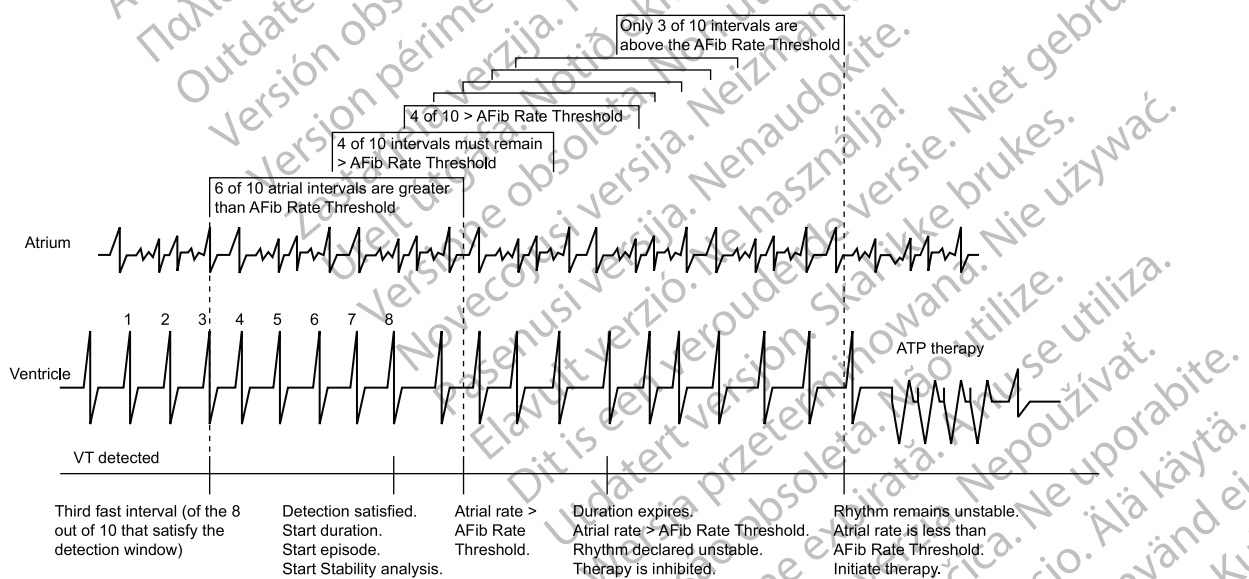

Figure 2–20. Interaction of AFib Rate Threshold and Stability

When AFib Rate Threshold and Stability are used alone, ventricular therapy is initiated when a stable rhythm is declared. Ventricular therapy is initiated for an unstable rhythm when it is determined that the atrial rate is less than the AFib Rate Threshold (Table 2–10 AFib Rate Threshold and Stability combinations and resulting therapy on page 2-27). When AFib Rate Threshold and Stability are used with other inhibitor enhancements, ventricular therapy is not always initiated when no longer inhibited by AFib Rate Threshold/Stability. Therapy may continue to be inhibited by other programmed detection enhancements, such as Onset (when the Onset/Stability detection enhancement suite is enabled) or Vector Timing and Correlation (when the Rhythm ID detection enhancement suite is enabled).

Consider the following information during these interactions:

- The AFib Rate Threshold and V Rate > A Rate detection enhancements are not evaluated if Atrial Tachyarrhythmia Discrimination is programmed to Off in a Rhythm ID configuration.
- Because the AFib Rate Threshold is not evaluated during redetection (following ventricular ATP therapy delivery, any aborted ventricular therapy, or therapy not available), the Episode Detail Report will not display data for the enhancement during redetection, even though the parameter is programmed On.
- The AFib Rate Threshold enhancement is not evaluated for arrhythmia detection in the following cases; however, the Episode Detail Report will still display the data for the AFib Rate Threshold enhancement based on a threshold of 170 min⁻¹:
 - The AFib Rate Threshold is programmed to Off
 - Ventricular Zones is programmed to 1
 - No detection enhancement suite is enabled
- An atrial sense event will only be classified as AF while the AFib Rate Threshold is being evaluated for arrhythmia detection.

Table 2-10. AFib Rate Threshold and Stability combinations and resulting therapy

Detected Ventricular Rhythm ^a	Therapy Decision ^b
Unstable, A > AFib Rate Threshold	Inhibit
Stable, A > AFib Rate Threshold	Treat
Unstable, A < AFib Rate Threshold	Treat
Stable, A < AFib Rate Threshold	Treat

a. If the detected ventricular rhythm changes, then the appropriate, corresponding row in the table is evaluated.

b. Decisions to inhibit can be overridden by V > A or expiration of SRD.

NOTE: Refer to "Use of Atrial Information" on page 2-6 for additional information about device performance when the atrial lead is programmed to Off.

Stability Analysis

This feature is available in AUTOGEN, DYNAGEN, INOGEN, ORIGEN, INCEPTA, ENERGEN, PUNCTUA, and COGNIS devices.

Stability analysis distinguishes Unstable (irregular) ventricular rhythms from Stable (regular) ventricular rhythms. This is accomplished by measuring the degree of variability of the tachycardia R–R intervals.

This degree of variability, when used alone, may allow the device to distinguish conducted AF (which may produce greater R–R variability) from monomorphic VT (which is typically stable). It also may be used to differentiate MVTs (which are pace terminable) from polymorphic VTs and VF (which are typically not pace terminable).

Based on the patient's needs, you may choose to program Stability as an inhibitor to prevent therapy for AF, or use stability analysis to direct the type of therapy to be delivered (Shock if Unstable).

The stability algorithm calculates RV R–R interval differences. These differences are calculated throughout Duration; an average difference is also calculated. When Duration expires, rhythm stability is evaluated by comparing the current average difference to the programmed Stability threshold and/or Shock if Unstable thresholds. If the average difference is greater than the

programmed thresholds, the rhythm is declared Unstable. Independent thresholds are available for the Stability (to inhibit) or Shock if Unstable functions; you cannot program both in the same ventricular zone.

The pulse generator performs stability calculations for all episodes (even when Stability is programmed to Off) and stores the results in Therapy History. This stored data may be used to select an appropriate stability threshold.

Stability to Inhibit

The Stability parameter may help you identify rapid rhythms originating in the atrium, such as AF. These rhythms may result in unstable ventricular rhythms whose rate exceeds the lowest rate threshold and should not be treated. If a rhythm is declared stable when Duration expires, programmed therapy will be delivered. If the rhythm is declared Unstable, ventricular therapy will be inhibited.

At the end of initial Duration, if a tachycardia is declared Unstable and ventricular therapy is inhibited, the pulse generator continues to evaluate for stability on each new detected interval (Figure 2–21 Stability evaluation when Duration expires on page 2-28). Therapy will not be inhibited by Stability if:

- V Rate > A Rate declares the ventricular rate greater than the atrial rate
- The SRD has expired (if programmed to On)

Ventricular therapy is not always initiated when no longer inhibited by Stability. Therapy may continue to be inhibited by other programmed detection enhancements, such as Onset (when the Onset/Stability detection enhancement suite is enabled) or Vector Timing and Correlation (when the Rhythm ID detection enhancement suite is enabled).

NOTE: Ventricular Therapy can also be inhibited through analysis of the Stability algorithm as it is used with the AFib Rate Threshold enhancement.

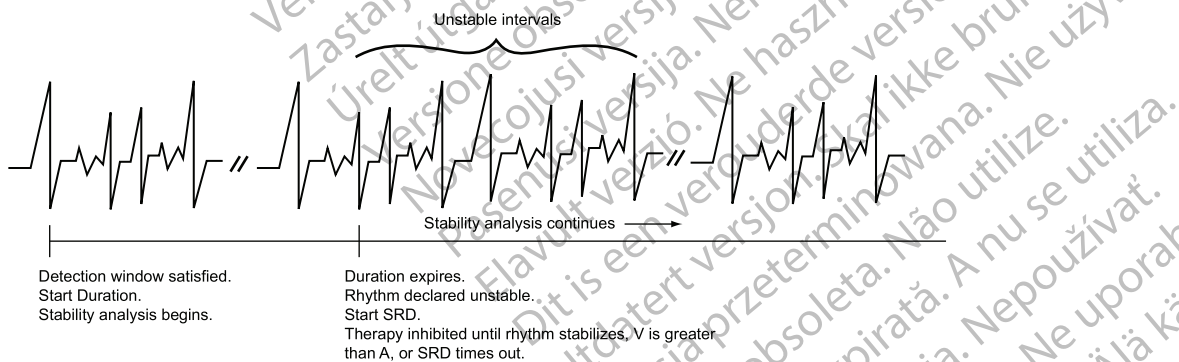

Figure 2–21. Stability evaluation when Duration expires

Shock if Unstable

When programmed to Shock if Unstable, the stability analysis helps determine if ventricular ATP therapy should be bypassed in preference for the first programmed ventricular shock therapy (which may be low- or high-energy) for the ventricular zone (Figure 2–22 Shock if Unstable on page 2-29).

Dynamic ventricular arrhythmias such as polymorphic VT or VF may be sensed at a rate lower than the highest ventricular rate threshold and can be classified as Unstable. Since the sensed rhythm may be detected in a lower ventricular zone in which ATP may be programmed, the stability analysis may be used to skip over the programmed ventricular ATP therapies and

instead provide shocks to the patient. Stability is evaluated on each detection/redetection cycle, including evaluation between bursts of an ATP scheme. Once a ventricular shock has been delivered in an episode, the Shock if Unstable function no longer affects therapy selection.

Shock if Unstable may be used only in the VT zone of a 2- or 3-zone configuration. You cannot program it in a 2-zone configuration if Stability or Onset is already programmed to On, or if Post V Shock Stability or AFib Rate Threshold is programmed to On.

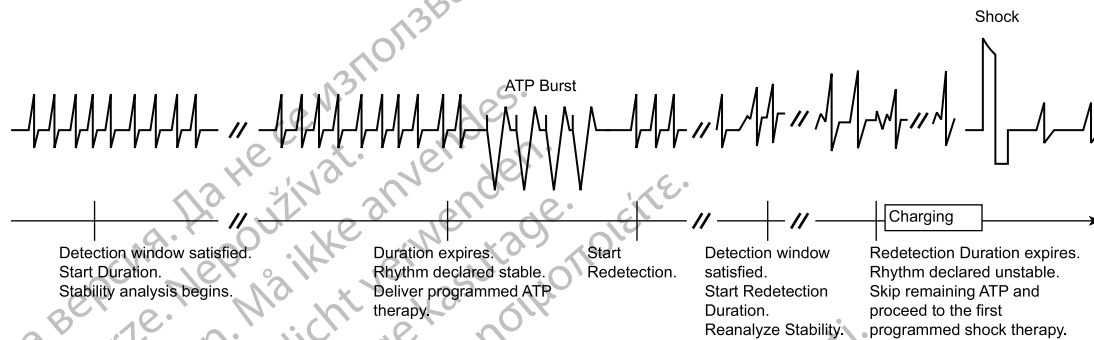

Figure 2-22. Shock if Unstable

Onset

This feature is available in AUTOGEN, DYNAGEN, INOGEN, ORIGEN, INCEPTA, ENERGEN, PUNCTUA, and COGNIS devices.

Onset differentiates physiologic sinus tachycardias, which typically begin slowly, from pathologic tachycardias, which typically begin abruptly. It measures the rate of transition in the ventricular rhythm from slow rates to tachycardia. If the rate increase is gradual, it enables the device to inhibit ventricular therapy in the lowest tachycardia rate zone.

When a detection window becomes satisfied, the pulse generator begins calculating for sudden Onset in a two-stage sequence.

- Stage 1 measures the ventricular intervals prior to the start of the episode and locates the pair of adjacent intervals (pivot point) where the cycle length decreased the most. If the decrease in cycle length is equal to or greater than the programmed Onset value, stage 1 declares sudden Onset.
- Stage 2 then compares additional intervals. If the difference between the average interval before the pivot point and 3 out of the first 4 intervals following the pivot point is equal to or greater than the programmed Onset Threshold, stage 2 declares sudden Onset.

If both stages declare the rhythm sudden, therapy will be initiated. If either stage indicates a gradual onset, initial ventricular therapy will be inhibited in the lowest zone. Therapy will not be inhibited by Onset if:

- The rate accelerates to a higher ventricular zone
- Information from the atrial lead determines that the RV rate is faster than the atrial rate (V Rate > A Rate programmed to On)
- The SRD timer expires

Onset is measured using RV intervals only. It can be programmed as a percentage of cycle length or as an interval length (in ms). It is limited to the lowest therapy zone of a multi-zone configuration. The selected Onset value represents the minimum difference that must exist between intervals that are above and below the lowest programmed rate threshold. The pulse

generator performs Onset calculations (even when the feature is programmed to Off) for all episodes except induced or commanded episodes. The measured Onset results from a two-stage calculation are stored in Therapy History. This stored data may be used to program an appropriate Onset value.

Sustained Rate Duration (SRD)

This feature is available in AUTOGEN, DYNAGEN, INOGEN, ORIGEN, INCEPTA, ENERGEN, PUNCTUA, and COGNIS devices.

Sustained Rate Duration allows delivery of the programmed ventricular therapy when a tachycardia is sustained for a programmed period beyond Duration, but the programmed therapy inhibitors (Vector Timing and Correlation, AFib Rate Threshold, Onset, and/or Stability) indicate to withhold therapy (Figure 2–23 Combination of Onset OR Stability, SRD programmed on on page 2-30).

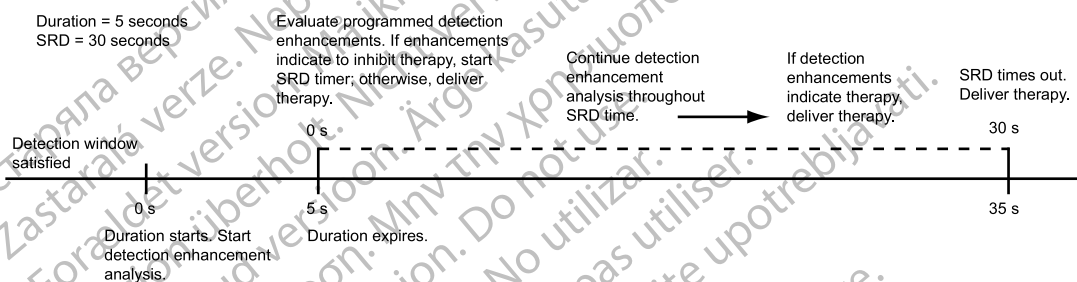

Figure 2–23. Combination of Onset OR Stability, SRD programmed on

SRD is available in a zone only when an inhibitor enhancement is programmed on in that zone. When the Rhythm ID detection enhancement suite is enabled, SRD may be programmed separately for the VT and VT-1 zones.

- A programmed SRD timer begins if ventricular therapy is withheld when the Duration expires in a zone where detection enhancements are programmed On.
- If the detection window in the lowest zone is maintained for the programmed SRD period, the programmed ventricular therapy will be delivered at the end of the VT-1 SRD period if VT-1 SRD is programmed and the rhythm is in the VT-1 zone. Therapy will be delivered at the end of the VT SRD period if VT SRD is programmed and the rhythm is in the VT zone.
- If the rate accelerates to a higher ventricular zone, detection enhancements are not programmed to On in the higher zone, and the Duration for the higher zone expires, therapy is initiated in that zone without waiting for SRD time-out in a lower ventricular zone. If SRD is programmed to Off, an SRD timer will not start when Duration expires, thus allowing detection enhancements to potentially inhibit therapy indefinitely.

An independent Post-shock SRD value may be programmed.

Combinations of AFib Rate Threshold, Stability, and Vector Timing and Correlation

This feature is available in AUTOGEN, DYNAGEN, INOGEN, INCEPTA, ENERGEN, and COGNIS devices.

The combination of AFib Rate Threshold, Stability, and Vector Timing and Correlation add specificity to ventricular detection beyond rate and duration. In addition to using AFib Rate Threshold and Stability to identify AF, this combination of enhancements uses Vector Timing and Correlation analysis to differentiate SVT rhythms from VT rhythms based on conduction patterns within the heart.

The AFib Rate Threshold, Stability, and Vector Timing and Correlation detection enhancement combination also includes V Rate > A Rate; both AFib Rate Threshold and V Rate > A Rate are enabled when Atrial Tachyarrhythmia Discrimination is programmed to On. This combination is only available when the Rhythm ID detection enhancement suite is enabled, and only for Initial Detection (Table 2–11 AFib Rate Threshold, Stability, and Vector Timing and Correlation combinations and resulting therapy decision if Atrial Tachyarrhythmia Discrimination is programmed to On on page 2-31).

If V Rate > A Rate is programmed to On (by programming Atrial Tachyarrhythmia Discrimination to On) and is True, it will take precedence over all inhibitor enhancements.

Table 2–11. AFib Rate Threshold, Stability, and Vector Timing and Correlation combinations and resulting therapy decision if Atrial Tachyarrhythmia Discrimination is programmed to On

Detected Ventricular Rhythm ^{a b c}	Therapy Decision ^d
Correlated, Unstable, A > AFib Rate Threshold	Inhibit
Correlated, Unstable, A < AFib Rate Threshold	Inhibit
Uncorrelated, Unstable, A > AFib Rate Threshold	Inhibit
Uncorrelated, Unstable, A < AFib Rate Threshold	Treat
Correlated, Stable, A > AFib Rate Threshold	Inhibit
Correlated, Stable, A < AFib Rate Threshold	Inhibit
Uncorrelated, Stable, A > AFib Rate Threshold	Treat
Uncorrelated, Stable, A < AFib Rate Threshold	Treat

- a. If the detected ventricular rhythm changes, then the appropriate, corresponding row in the table is evaluated.
 b. If a Rhythm ID reference template is not available, the detected ventricular rhythm is considered to be Uncorrelated.
 c. For Post-Shock Detection (if enabled), Vector Timing and Correlation is considered to be Uncorrelated.
 d. Decisions to inhibit can be overridden by V > A or expiration of SRD.

When Atrial Tachyarrhythmia Discrimination is programmed to Off, then Vector Timing and Correlation is used for Initial Detection and Stability is used for Post-Shock Detection. V Rate > A Rate and AFib Rate Threshold are no longer used (Table 2–12 Vector Timing and Correlation and Stability combinations with resulting therapy decision if Atrial Tachyarrhythmia Discrimination is programmed to Off on page 2-31).

Table 2–12. Vector Timing and Correlation and Stability combinations with resulting therapy decision if Atrial Tachyarrhythmia Discrimination is programmed to Off

Detection ^{a b}	Detected Ventricular Rhythm ^{a c}	Therapy Decision
Initial	Correlated	Inhibit ^d
Initial	Uncorrelated	Treat
Post-Shock	Unstable	Inhibit ^d
Post-Shock	Stable	Treat

- a. If the detected ventricular rhythm changes, then the appropriate, corresponding row in the table is evaluated.
 b. If Atrial Tachyarrhythmia Discrimination is programmed to Off, then Vector Timing and Correlation is used for Initial Detection, and Stability is used for Post-Shock Detection.
 c. If a Rhythm ID reference template is not available, the detected ventricular rhythm is considered to be Uncorrelated.
 d. Decision to inhibit can be overridden by expiration of SRD.

Combinations of AFib Rate Threshold, Stability, and Onset

The combination of AFib Rate Threshold, Stability, and Onset add specificity to ventricular detection beyond rate and duration. This combination of detection enhancements is available only when the Onset/Stability detection enhancement suite is enabled and is available only for Initial Detection. When detection enhancements are enabled, they will act to recommend or inhibit therapy for a specific zone.

If AFib Rate Threshold, Stability, and Onset parameters are all programmed to On, ventricular therapy will be initiated if the rhythm has a sudden onset provided that either the ventricular rate is stable or the atrial rate is less than the AFib Rate Threshold (Table 2–13 AFib Rate Threshold, Stability, and Onset combinations and resulting ventricular therapy on page 2-32).

Table 2–13. AFib Rate Threshold, Stability, and Onset combinations and resulting ventricular therapy

Detected Ventricular Rhythm ^a	Therapy Decision ^b
Gradual, Unstable, A > AFib Rate Threshold	Inhibit
Gradual, Unstable, A < AFib Rate Threshold	Inhibit
Sudden, Unstable, A > AFib Rate Threshold	Inhibit
Sudden, Unstable, A < AFib Rate Threshold	Treat ^c
Gradual, Stable, A > AFib Rate Threshold	Treat
Gradual, Stable, A < AFib Rate Threshold	Inhibit
Sudden, Stable, A > AFib Rate Threshold	Treat
Sudden, Stable, A < AFib Rate Threshold	Treat

- a. If the detected ventricular rhythm changes, then the appropriate, corresponding row in the table is evaluated.
- b. Decisions to inhibit can be overridden by V > A or expiration of SRD.
- c. If V Rate > A Rate is programmed to On and is False, ventricular therapy will be inhibited because the rhythm is unstable.

If V Rate > A Rate is programmed to On and is True, it will take precedence over all inhibitor enhancements.

Combinations of Onset and Stability

When Stability is programmed to inhibit, it may be combined with Onset to provide even greater specificity in classifying arrhythmias.

This combination of detection enhancements is available only when the Onset/Stability detection enhancement suite is enabled and is available only for Initial Detection. The enhancements can be programmed to initiate ventricular therapy if the following options are selected (Table 2–14 Combinations of Onset And Stability and resulting therapy on page 2-33):

- Both Onset And Stability indicate to treat
- Either Onset Or Stability indicates to treat

Based on these programming decisions, ventricular therapy is inhibited when any of the following criteria is met:

- If the combination programmed is Onset And Stability, ventricular therapy is inhibited if either parameter indicates that therapy should be withheld; that is, the rhythm is gradual Or unstable (the And condition to treat is not satisfied).
- If the combination programmed is Onset Or Stability, ventricular therapy is inhibited immediately at the end of Duration only if both parameters indicate that therapy should be withheld; that is, the rhythm is gradual and unstable (the Or condition to treat is not satisfied).

In either case, ventricular therapy will be initiated only if the And/Or conditions to treat are satisfied. When these two combinations (And/Or) are used in conjunction with SRD, and the And/Or conditions are not satisfied, ventricular therapy will be inhibited until V Rate > A Rate is True or SRD times out (Table 2–14 Combinations of Onset And Stability and resulting therapy on page 2-33).

Остаряла версия. Да не се използва.
Zastaralá verze. Nepoužívat.
Forældet version. Må ikke anvendes.
Version überholt. Nicht verwenden.
Aegunud versioón. Myn þyn χρησιμοποιείτε.
Παλιά έκδοση. Μην την χρησιμοποιείτε.
Outdated version. Do not use.
Versión obsoleta. No utilizar.
Zastarjela verzija. Nemojte upotrebljavati.
Úreilt útgáfa. Notið ekki.
Versione obsoleta. Ne pas utiliser.
Novecojsi versija. Non utilizzare.
Pasenusi versija. Neizmantot.
Elavult verzió. Ne használja!
Dit is een verouderde versie. Niet gebruiken.
Utdatert versjon. Skal ikke brukes.
Wersja przeterminowana. Nie używać.
Versão obsoleta. Não utilize.
Versiune expirată. A nu se utiliza.
Zastaraná verzia. Nepoužívať.
Vanhentunut versio. Älä käytä.
Föråldrad version. Använd ej.
Güncel olmayan sürüm. Kullanmayın.

TACHYARRHYTHMIA THERAPY

CHAPTER 3

This chapter contains the following topics:

- “Ventricular Therapy” on page 3-2
- “Antitachycardia Pacing Therapies and Parameters” on page 3-7
- “Ventricular Shock Therapy and Parameters” on page 3-15

Остаряла версия. Да не се използва.
Zastaralá verze. Nepoužívat.
Forældet version. Må ikke anvendes.
Version überholt. Nicht verwenden.
Version obsolete. Ärge kasutage.
Παλιά έκδοση. Μην την χρησιμοποιείτε.
Outdated version. Do not use.
Version obsolete. Ne utilizar.
Zastarjela verzija. Nemojte upotrebljavati.
Úreлт útgáfa. Notið ekki.
Versione obsoleta. Non utilizzare.
Pasenusi verzija. Neizmantoť.
Elavult verzió. Ne használja!
Dit is een verouderde versie. Niet gebruiken.
Wersja przeterminowana. Nie używać.
Versão obsoleta. Não utilize.
Versione expirată. A nu se utiliza.
Zastaraná verzia. Nepoužívať.
Vanhentunut versio. Älä käytä.
Föråldrad version. Använd ej.
Güncel olmayan sürüm. Kullanmayın.

VENTRICULAR THERAPY

The pulse generator can deliver the following types of therapy to terminate VT or VF:

- Antitachycardia pacing (ATP)
- Cardioversion/defibrillation shocks

ATP pacing schemes are bursts of pacing pulses delivered between the ventricular pace/sense electrodes. Shocks are high-voltage biphasic pulses delivered through the shocking electrodes synchronously with detected heart activity.

NOTE: Tachycardia therapy decisions are based on cardiac cycle length by using RV sensed events only.

WARNING: During MRI Protection Mode, Tachycardia therapy is suspended. The system will not detect ventricular arrhythmias and the patient will not receive ATP or shock defibrillation therapy until the pulse generator is programmed back to normal operation. Only scan the patient if judged to be clinically capable of tolerating no Tachycardia protection for the entire duration in which the pulse generator is in MRI Protection Mode.

Ventricular Therapy Prescription

This feature is available in AUTOGEN, DYNAGEN, INOGEN, ORIGEN, INCEPTA, ENERGEN, PUNCTUA, and COGNIS devices.

A ventricular therapy prescription determines the type of therapy to be delivered in a particular ventricular rate zone. It consists of ventricular ATP and/or shocks. Each ventricular zone may be programmed with independent ventricular therapy prescriptions (Figure 3–1 Ventricular therapy prescription, 3-zone configuration on page 3-2).

Within each zone, therapy strength must be in ascending order.

Lowest strength → Highest strength

Zone	ATP1 ²	ATP2 ²	QUICK CONVERT ATP	Shock 1 ¹	Shock 2 ¹	Remaining (Maximum) Shocks ¹
VF	Not available		On/Off	0.1-max J	0.1-max J	max J
VT	All ATP types available	All ATP types available	N/A	0.1-max J	0.1-max J	max J
VT-1	All ATP types available	All ATP types available	N/A	0.1-max J	0.1-max J	max J

Between zones, therapy strengths are not restricted.

¹ In the lowest zone of a multi-zone configuration, some or all of the shocks may be programmed to Off, starting with the maximum shocks first. If the maximum shocks are programmed to Off, then Shock 2 can be programmed to Off. If Shock 2 is programmed to Off, then Shock 1 can be programmed to Off. If the arrhythmia persists in the lowest zone when some or all of the shocks are programmed to Off, no further therapy will be delivered unless the arrhythmia accelerates to a higher zone. A Disable Therapy button is available in the VT or VT-1 zones' therapy window to quickly disable all ATP and Shock therapy in that zone.

² Ventricular ATP therapy can be programmed as Off, Burst, Ramp, Scan, or Ramp/Scan in VT-1 and VT zones.

³ Quick Convert ATP can be programmed to a rate of 250 or 300. This footnote applies to this and all subsequent tables in this section.

Figure 3–1. Ventricular therapy prescription, 3-zone configuration

The therapies within a ventricular zone must be ordered in ascending therapy strengths. All ventricular ATP therapies are considered to be of equal strength, but are of lower strength than any shock therapy. The strength of the shock therapies is determined by the programmed energy. In a multi-zone configuration, therapies in a higher ventricular zone may be of lesser, greater, or equal strength to those in a lower ventricular zone; however, within each zone the therapies must be programmed in equal or increasing energy output.

Ventricular Therapy Selection

The pulse generator determines which ventricular therapy to deliver based on the following rules:

- Each successive therapy delivery must be greater than or equal to the strength of the previous therapy in a ventricular episode. Whenever a ventricular shock therapy has been delivered, no further ventricular ATP therapy is allowed in that episode since ATP therapy is of lower strength than shock therapy. Each subsequent ventricular shock delivery must be of equal or greater strength regardless of ventricular zone changes during a ventricular episode.
- Each ventricular ATP scheme (which may consist of multiple bursts) can only be delivered once during a ventricular episode.
- Up to 8 shocks may be delivered in a ventricular episode. The first 2 shocks are programmable. The following maximum-energy, non-programmable shocks are available in each zone:
 - VT-1 zone: 3 maximum-energy shocks
 - VT zone: 4 maximum-energy shocks
 - VF zone: 6 maximum-energy shocks

NOTE: In the event a shock is diverted with the *DIVERT THERAPY* programmer command, by magnet application or due to a *Diverted-Reconfirm*, the diverted shock is not counted as one of the available shocks for that tachyarrhythmia episode. Also, commanded therapies and *STAT SHOCK* are not counted as one of the available shocks for an episode and do not affect subsequent therapy selection.

Based on initial ventricular detection criteria, the pulse generator selects the first prescribed therapy in the ventricular zone in which the tachyarrhythmia is detected (i.e., detection is met; refer to "Ventricular Detection" on page 2-7). After delivering the selected therapy, the pulse generator begins redetection to determine whether the arrhythmia has been converted.

- If the arrhythmia is converted to a rate below the lowest programmed threshold, the pulse generator continues monitoring until the end of the episode is declared. When the episode ends, the pulse generator will again use initial ventricular detection criteria for a new episode. When a new episode is declared, the first prescribed therapy will be delivered again.
- If the arrhythmia is not converted and an arrhythmia is redetected in the same ventricular zone, the next programmed therapy in that zone is selected and delivered (Figure 3–2 Therapy delivery progression, arrhythmia remains in same zone as initially detected on page 3-4), followed again by redetection. If the arrhythmia persists in the same zone, the therapy will progress in that zone.
- If an arrhythmia crosses ventricular zones (accelerates or decelerates) following therapy delivery and is redetected in a higher or lower ventricular zone, a therapy of equal or greater strength than the previously delivered therapy is selected from the detected zone and delivered. For shock therapy, the pulse generator determines which shock to deliver prior to capacitor charging based on the detected rate threshold. If during capacitor charging, the tachyarrhythmia accelerates or decelerates from the initial detected rate, the predetermined energy will still be delivered.

Refer to Figure 3–3 Therapy delivery progression, ATP1 in the VT zone and shock 2 in the VF zone on page 3-4 through Figure 3–10 Therapy delivery progression, ATP1 in VT zone accelerates the rhythm, QUICK CONVERT ATP is skipped in VF zone on page 3-6.

Redetection is performed after each therapy deliver to determine if further therapy is required. Use the following information when interpreting the therapy progression figures:

- After each redetection cycle, therapy delivery progresses in the direction indicated by the circled numbers.
- Upward sloping lines indicate acceleration of the arrhythmia to a higher ventricular zone.
- Downward sloping lines indicate deceleration into a lower ventricular zone.
- The lowest strength therapy is in the ATP columns; the therapy strengths increase as you move to the right in the table.

NOTE: In the VT-1 zone of a 3-zone configuration or the VT zone of a 2-zone configuration, one or two ATP schemes may be programmed as the only therapy, with all shocks in the lowest zone programmed to Off. If those pacing schemes do not terminate an arrhythmia detected in the lowest zone, no further therapy will be delivered in the episode unless the rate is redetected in a higher zone.

Zone	ATP1	ATP2	QUICK CONVERT ATP	Shock 1	Shock 2	Remaining Shocks
VF			On/Off	5 J	11 J	max max max max max max
VT	Burst	Scan	N/A	3 J	9 J	max max max max
VT-1	① Burst	② Ramp	N/A	③ 0.1 J	④ 2 J	⑤ max ⑥ max ⑦ max

Figure 3-2. Therapy delivery progression, arrhythmia remains in same zone as initially detected

Zone	ATP1	ATP2	QUICK CONVERT ATP	Shock 1	Shock 2	Remaining Shocks
VF			On/Off	2 J	⑤ 11 J	max max max max max max
VT	③ Burst	Off	N/A	④ 3 J	9 J	⑥ max ⑦ max ⑧ max ⑨ max
VT-1	① Burst	② Ramp	N/A	0.1 J	2 J	max max max

Figure 3-3. Therapy delivery progression, ATP1 in the VT zone and shock 2 in the VF zone

Zone	ATP1	ATP2	QUICK CONVERT ATP	Shock 1	Shock 2	Remaining Shocks
VF			On/Off	11 J	17 J	max ⑦ max max max max max
VT	① Burst	③ Scan	N/A	④ 5 J	9 J	⑥ max max ⑧ max ⑨ max
VT-1	② Burst	Ramp	N/A	3 J	⑤ 5 J	max max max

Figure 3-4. Therapy delivery progression, ATP2 therapy

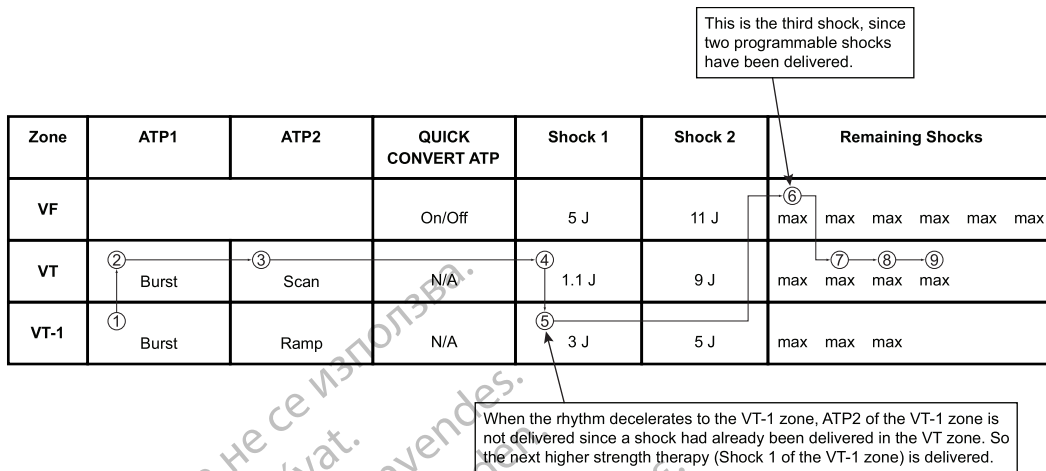

Figure 3-5. Therapy delivery progression, shock 1 in the VT-1 zone

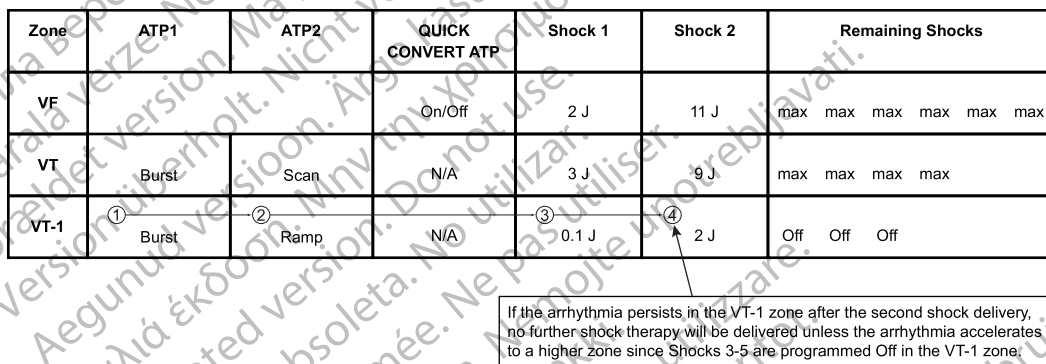

Figure 3-6. Therapy delivery progression, shocks 3 to 5 programmed to Off in the VT-1 zone

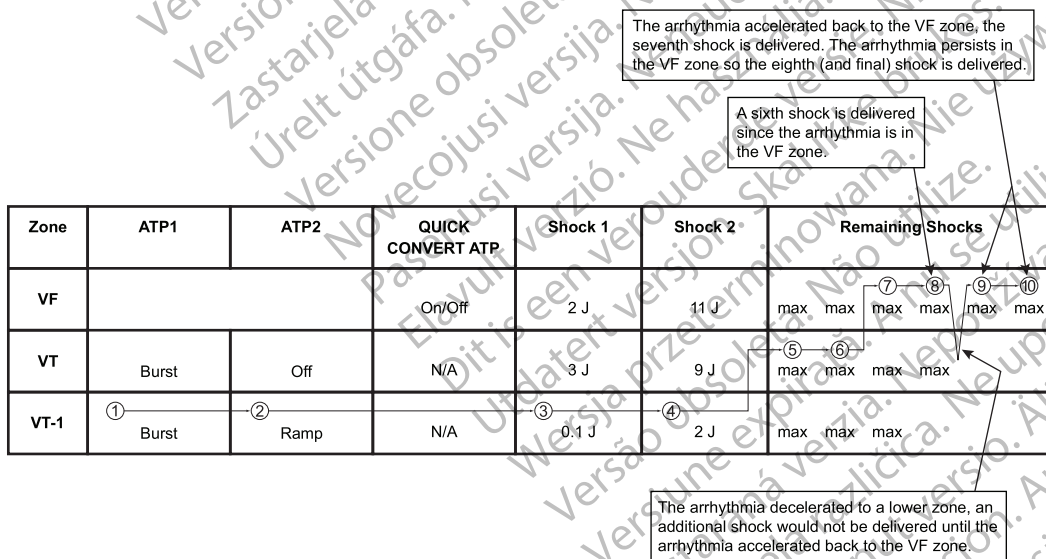

Figure 3-7. Therapy delivery progression, sixth shock delivered

If reconfirmation indicates the arrhythmia persists after delivery of QUICK CONVERT ATP, the device immediately begins charging for Shock 1.

Zone	ATP1	ATP2	QUICK CONVERT ATP	Shock 1	Shock 2	Remaining Shocks
VF			① On	② 11 J	③ 21 J	max max max max max max
VT	Burst	Scan	N/A	3 J	9 J	max max max max
VT-1	Burst	Ramp	N/A	0.1 J	2 J	max max max

Figure 3–8. Therapy delivery progression, QUICK CONVERT ATP and shock in the VF zone

Zone	ATP1	ATP2	QUICK CONVERT ATP	Shock 1	Shock 2	Remaining Shocks
VF			① On	2 J	11 J	max max max max max max
VT	② Burst	③ Scan	N/A	④ 3 J	⑤ 9 J	max max max max
VT-1	Burst	Ramp	N/A	0.1 J	2 J	max max max

ATP1 in the VT zone is delivered because it is considered of equal strength to QUICK CONVERT ATP therapy.

Figure 3–9. Therapy delivery progression, QUICK CONVERT ATP decelerates the rhythm, ATP1 and shock delivered in the VT zone

When the rhythm accelerates to the VF zone, Shock 1 is delivered because QUICK CONVERT ATP is only available as the first therapy in an episode.

Zone	ATP1	ATP2	QUICK CONVERT ATP	Shock 1	Shock 2	Remaining Shocks
VF			On	② 11 J	③ 21 J	max max max max max max
VT	① Burst	Scan	N/A	3 J	9 J	max max max max
VT-1	Burst	Ramp	N/A	0.1 J	2 J	max max max

Figure 3–10. Therapy delivery progression, ATP1 in VT zone accelerates the rhythm, QUICK CONVERT ATP is skipped in VF zone

Ventricular Redetection after Ventricular Therapy Delivery

After ventricular therapy delivery, the pulse generator uses redetection criteria to evaluate the rhythm and determine whether more therapy is appropriate. When redetection criteria are satisfied, the rules for therapy selection then determine the type of therapy to deliver.

Ventricular Redetection after Ventricular ATP Therapy

Ventricular Redetection after ventricular ATP therapy determines if an arrhythmia has been terminated.

As a ventricular ATP scheme is delivered, the pulse generator monitors the cardiac rate after each burst and uses ventricular detection windows (looking for 8 of 10 fast intervals) and the Ventricular Redetection Duration to determine if the arrhythmia has terminated.

The ATP scheme will continue with the next bursts in the sequence until any one of the following conditions is satisfied:

- Redetection declares that the therapy has been successful (end-of-episode)
- The specified number of ATP bursts in the scheme has been delivered
- The ATP Time-out for the ventricular zone has expired
- The detected ventricular arrhythmia rate changes to a different ventricular rate zone, whereby a different therapy is selected
- Shock If Unstable forces the device to skip the remaining ATP therapy and initiate shock therapy
- A DIVERT THERAPY command is received from the PRM during delivery of a burst of a scheme
- A magnet abort occurs during delivery of a scheme
- The temporary Tachy Mode has changed
- A commanded therapy is requested
- The episode ends due to reprogrammed Tachy Mode, reprogrammed ventricular tachy parameters, or attempted induction method or lead test

NOTE: *Aborting an ATP burst terminates the affected ATP scheme. If further therapy is required, the next programmed therapy (either ATP or shocks) in the prescription is initiated.*

Ventricular Redetection after Ventricular Shock Therapy

Ventricular Redetection after ventricular shock therapy determines if an arrhythmia has been terminated.

As shock therapy is delivered, the pulse generator monitors the cardiac rate after each shock and uses ventricular detection windows (looking for 8 of 10 fast intervals) and post-shock detection enhancements, if applicable, to determine if the arrhythmia has been terminated. Shock therapy will continue until one of the following conditions is satisfied:

- Redetection declares the therapy has been successful (end-of-episode)
- All available ventricular shocks have been delivered for an episode
- The rhythm is redetected in either the VT or VT-1 zone, the available number of programmed shock(s) in those zones has been delivered and the arrhythmia stays in one of these lower zones

If all available shocks have been delivered for an episode, no further therapy is available until the pulse generator monitors a rate below the lowest rate threshold for 30 seconds and end-of-episode is declared.

ANTITACHYCARDIA PACING THERAPIES AND PARAMETERS

This feature is available in AUTOGEN, DYNAGEN, INOGEN, ORIGEN, INCEPTA, ENERGEN, PUNCTUA, and COGNIS devices.

Antitachycardia Pacing (ATP) therapy and parameters enable the pulse generator to interrupt the following fast rhythms by delivering a series of critically timed pacing pulses:

- Monomorphic ventricular tachycardia
- Supraventricular tachycardias

ATP Therapy is delivered when the last sensed event fulfills the programmed detection criteria (Figure 3–11 ATP therapy basic parameters are Coupling Interval, Burst Cycle Length, Number of Bursts, and Number of Pulses within each burst. on page 3-8).

An ATP scheme may be customized with the following parameters:

- Number of Bursts delivered
- Number of pulses within each burst
- Coupling Interval
- Burst Cycle Length
- Minimum pacing interval

These parameters can be programmed to produce the following ATP therapy schemes:

- Burst
- Ramp
- Scan
- Ramp/Scan

The ATP Amplitude and Pulse Width are common to all schemes. They are independently programmable from the normal pacing settings. The ATP Amplitude and Pulse Width share the same programmable value as the post-therapy pacing settings.

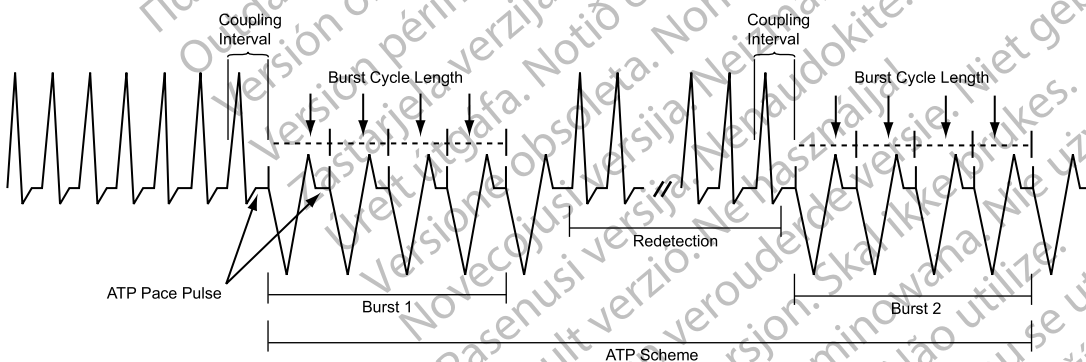

Figure 3–11. ATP therapy basic parameters are Coupling Interval, Burst Cycle Length, Number of Bursts, and Number of Pulses within each burst.

Burst Parameters

A burst is a series of critically timed pacing pulses delivered by the pulse generator during ATP therapy. By programming Burst parameters, you can optimize ATP therapy for the patient.

All ATP schemes have several parameters in common. In addition to programming the type of scheme (Off, Burst, Ramp, Scan, Ramp/Scan), the following Burst parameters are programmable (Figure 3–12 Interaction of Maximum Number of Pulses and Number of Bursts on page 3-9):

- The Number of Bursts parameter determines the number of bursts used in an ATP scheme and may be programmed independently for each ATP scheme. Programming the parameter to Off will deactivate the ATP scheme.

- The Initial Pulse Count parameter determines the number of pulses delivered in the first burst of a scheme.
- The Pulse Increment parameter determines the number of pulses per burst to be increased for each successive burst in the scheme.
- The Maximum Number of Pulses parameter determines the greatest number of pulses used in an ATP burst and may be programmed independently for each ATP scheme. After the maximum number of pulses is reached in a burst, each additional burst remaining in the scheme contains the programmed Maximum Number of Pulses. The parameter is available only if the Pulse Increment is greater than zero.

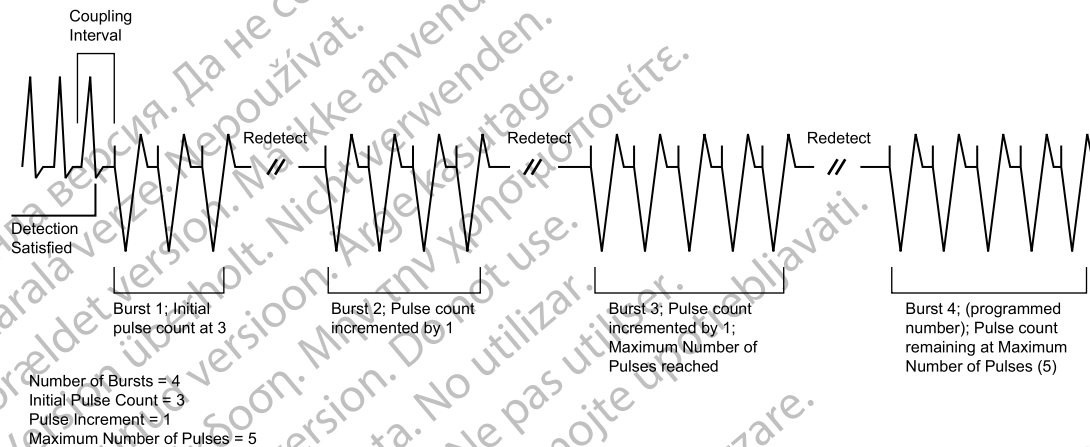

Figure 3-12. Interaction of Maximum Number of Pulses and Number of Bursts.

Coupling Interval and Coupling Interval Decrement

The Coupling Interval controls the timing of the first pulse in a burst. It defines the time between the last sensed event that fulfills the detection criteria and delivery of the first pulse in a burst.

The Coupling Interval is programmed independent from the Burst Cycle Length. This allows aggressive ramps and scans to be used without compromising capture of the first pacing pulse in a burst. The Coupling Interval can be programmed as any of the following:

- Adaptive, with timing specified as percentages of the computed average heart rate
- A fixed interval, with timing specified in absolute time (ms) independent of the measured average rate

When programmed as adaptive, the Coupling Interval adjusts to the patient's rhythm based on a four-cycle average (Figure 3-13 Adaptive Coupling Interval, Coupling Interval Decrement and Scan Decrement programmed to 0 on page 3-10). The Coupling Interval Decrement may be programmed such that the Coupling Interval decreases from one burst to the next within a multiple-burst scheme (Figure 3-14 Coupling Interval Decrement on page 3-10).

NOTE: You cannot program an ATP burst that lasts longer than 15 seconds. The length of an adaptive burst is calculated based on the interval of the ventricular zone in which the ATP is programmed, which means it is based on worst-case timing.

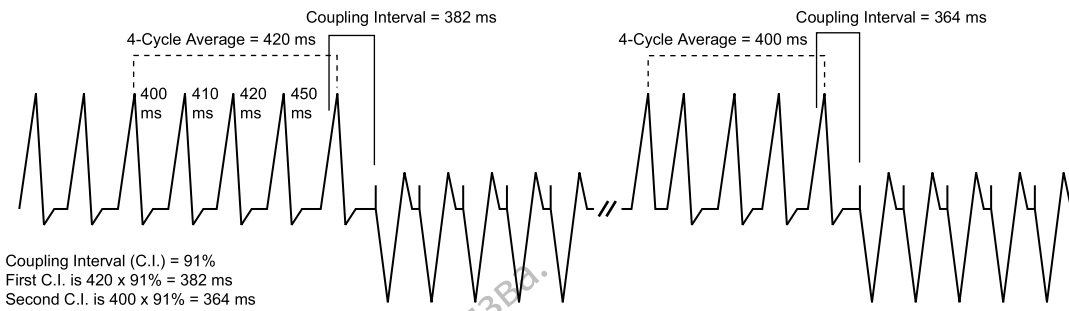

The 4-cycle average is calculated on the four cycles prior to each tachycardia therapy delivery only when no Decrement (Coupling Interval or Scan) is programmed.

Figure 3-13. Adaptive Coupling Interval, Coupling Interval Decrement and Scan Decrement programmed to 0

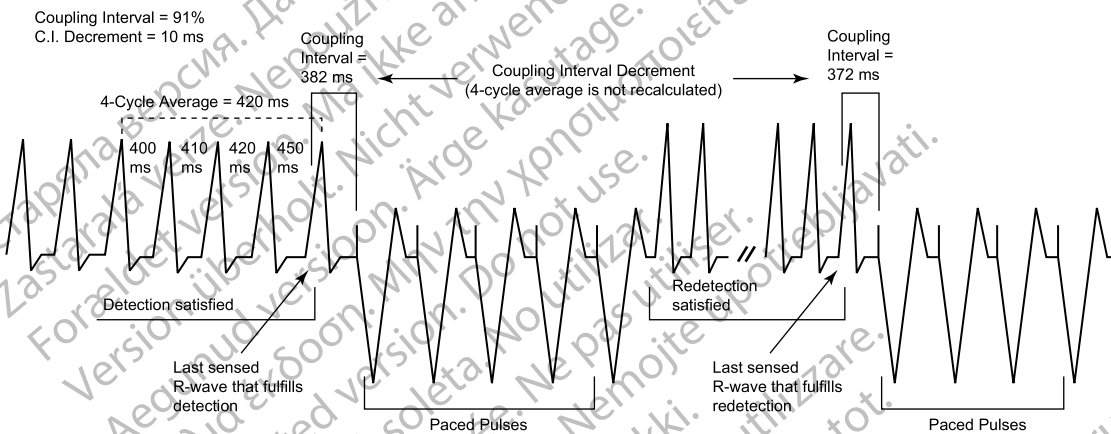

Figure 3-14. Coupling Interval Decrement

The following information should be taken into consideration when programming the Coupling Interval and Coupling Interval Decrement:

- When the Coupling Interval Decrement is programmed to On, the programmed ATP scheme is called a Scan
- When the Coupling Interval is programmed as adaptive, the Coupling Interval will not adapt following redetection when the following are programmed to On (greater than zero):
 - Coupling Interval Decrement—the decrement value determines the timing of the first pulse in subsequent bursts
 - Scan Decrement—the decrement value determines the timing of the second pulse in subsequent bursts

Burst Cycle Length (BCL)

The Burst Cycle Length controls the interval between pacing pulses after the Coupling Interval.

This timing is controlled in the same fashion as the Coupling Interval: rate adaptive to the sensed tachycardia or fixed time specified in ms.

NOTE: An adaptive BCL is affected in the same manner as an adaptive Coupling Interval; the average cycle length is not continually recalculated for subsequent bursts if the Scan Decrement or Coupling Interval Decrement are programmed to On.

The following parameters may be programmed to decrement the burst cycle length during an ATP scheme:

- Ramp Decrement controls the pulse timing within a given burst
- Scan Decrement controls the pulse timing between bursts

Minimum Interval

The Minimum Interval limits the Coupling Interval and the BCL in Burst, Ramp, and Scan.

If the Coupling Interval reaches the limit, subsequent Coupling Intervals will remain at the minimum value. Likewise, if the BCL reaches the limit, subsequent BCLs will remain at the minimum value. The Coupling Interval and BCL may reach the limit independently.

Burst Scheme

A Burst scheme is a sequence of critically timed pacing pulses intended to interrupt a reentrant loop, usually delivered at a rate faster than the patient's tachycardia.

An ATP scheme is defined as a Burst (as indicated on the PRM screen) when the timing of all pacing intervals within a burst is the same. The first BCL of each Burst is determined by the programmed BCL. When the number of pulses programmed in a Burst is greater than one, you can use the BCL to control the timing between these paced pulses (Figure 3–15 Adaptive-rate Burst scheme on page 3-11).

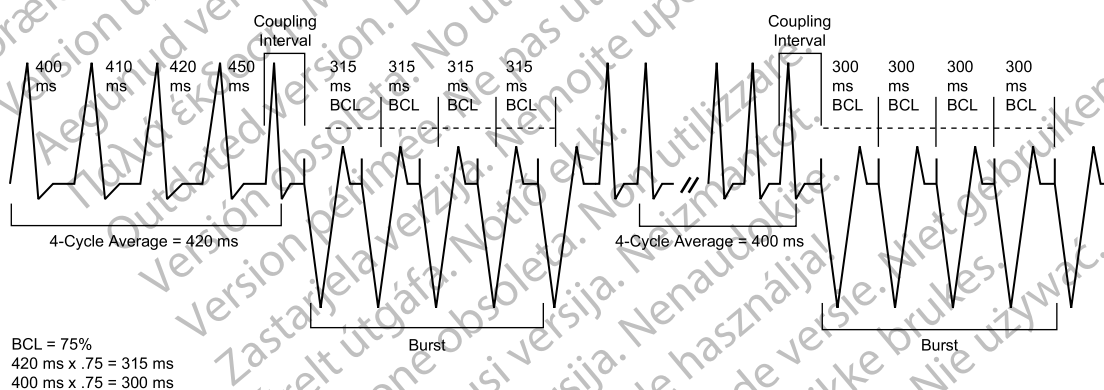

The first BCL of each burst is calculated by multiplying the 4-cycle average prior to delivery of the first pacing pulse of the burst by the BCL percentage.

Figure 3–15. Adaptive-rate Burst scheme

Ramp Scheme

A Ramp scheme is a burst in which each paced-to-paced interval within the burst is shortened (decremented).

To program a Ramp scheme, program (in ms) the Ramp Decrement to specify how much the paced-to-paced interval should be shortened, and the Scan Decrement and Coupling Interval Decrement each to 0 ms. As each additional paced pulse in a burst is delivered, its interval is shortened by the programmed Ramp Decrement until either of the following occur:

- The last paced pulse of the burst is delivered
- The Minimum Interval is reached

If subsequent bursts are required, the programmed Ramp Decrement will be applied based on the calculated BCL of that subsequent burst (Figure 3–16 Adaptive Ramp Scheme, Coupling Interval Decrement and Scan Decrement programmed to 0 on page 3-12).

3-12 Tachyarrhythmia Therapy
Antitachycardia Pacing Therapies and Parameters

Burst Cycle Length = 75%
 Ramp Decrement (R-R Within Burst) = 10 ms
 Scan Decrement (R-R Between Bursts) = 0 ms
 C.I. Decrement = 0 ms
 Minimum Interval = 265 ms

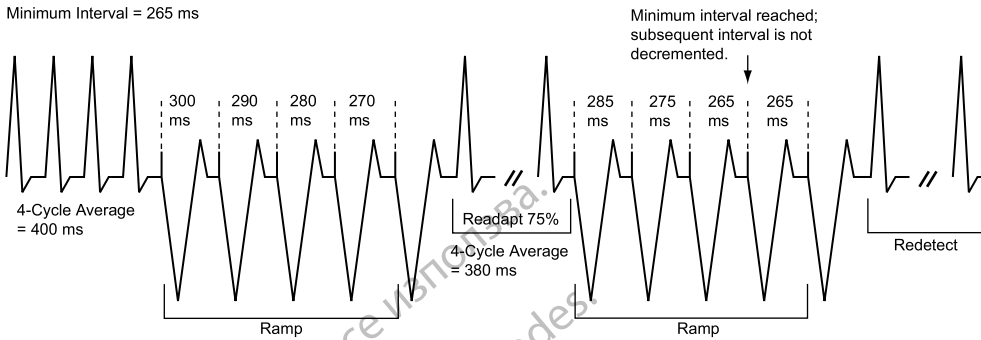

Figure 3-16. Adaptive Ramp Scheme, Coupling Interval Decrement and Scan Decrement programmed to 0

Scan Scheme

A Scan scheme is a burst in which the BCL of each burst in a scheme is systematically shortened (decremented) between successive bursts.

You can program a Scan scheme by programming the Scan Decrement to specify the BCL decrement to a value greater than 0 ms, while the Ramp Decrement is programmed to 0 ms. The BCL of subsequent bursts is determined by subtracting the Scan Decrement from the BCL of the previous burst (Figure 3-17 Scan scheme, nonadaptive BCL and Scan Decrement programmed on on page 3-12).

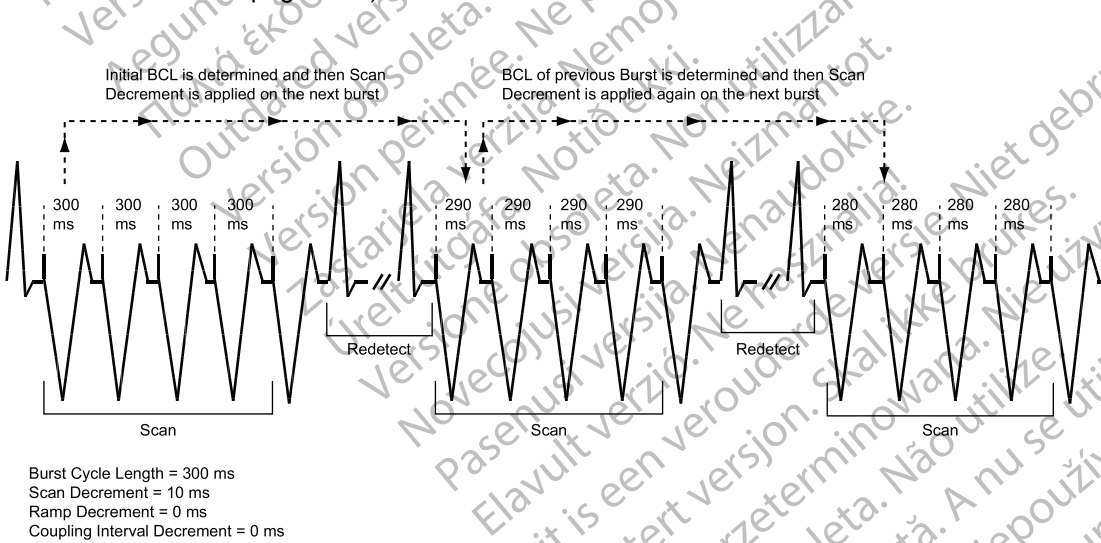

Figure 3-17. Scan scheme, nonadaptive BCL and Scan Decrement programmed on

Ramp/Scan Scheme

A Ramp/Scan scheme is a sequence of bursts. Each scheme contains a Ramp Decrement and a Scan Decrement (Figure 3-18 Ramp/Scan scheme, interaction of ATP parameters on page 3-13).

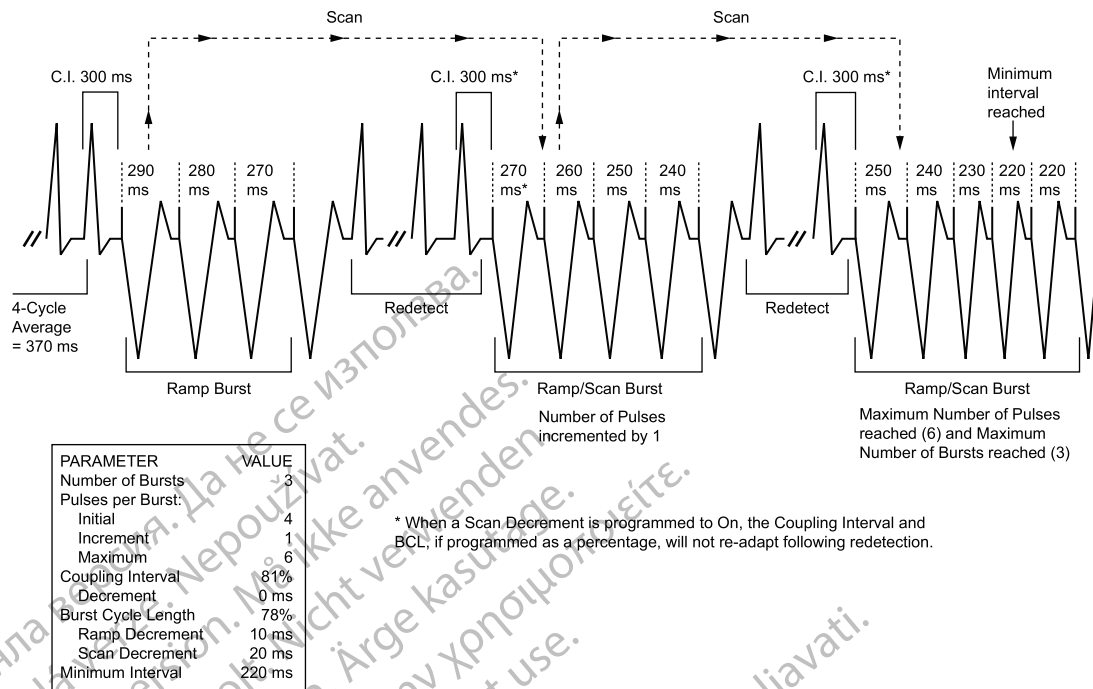

Figure 3-18. Ramp/Scan scheme, interaction of ATP parameters

To program a Ramp/Scan scheme, both the Scan Decrement and Ramp Decrement are programmed to values greater than 0 ms.

ATP Pulse Width and ATP Amplitude

The ATP Pulse Width is the duration of a pacing pulse. The ATP Amplitude is the leading edge voltage of a pacing pulse.

The ATP Pulse Width and ATP Amplitude parameters share the same value as the post therapy pacing Pulse Width and Amplitude. If the programmable value is changed for one parameter, that value will be reflected in the other parameters.

The programmed ATP Pulse Width and ATP Amplitude are shared for all ATP schemes regardless of zone and position in a prescription. The ATP Amplitude and Pulse Width share the same programmable value as the post-therapy pacing settings.

Ventricular ATP Time-out

The Ventricular ATP Time-out forces the pulse generator to skip over any remaining ATP therapy in a ventricular zone to begin delivering ventricular shock therapy programmed in the same zone. This parameter is effective only for ventricular therapy delivery.

The ATP Time-out may be used in the VT or VT-1 zone as long as ATP therapy is programmed to On. Timer values are independent, although VT-1 ATP Time-out must be equal to or greater than the VT ATP Time-out.

The timer starts when the first burst is delivered and continues until any of the following occur:

- The timer expires (Figure 3-19 ATP Time-out expiration, on page 3-14)
- A ventricular shock is delivered
- The ventricular episode ends

The time-out is examined after each redetection sequence to determine if further ATP bursts can be delivered. If the time-out has been reached or exceeded, further ATP therapy will not be initiated during that ventricular episode. The time-out will not terminate a burst in process.

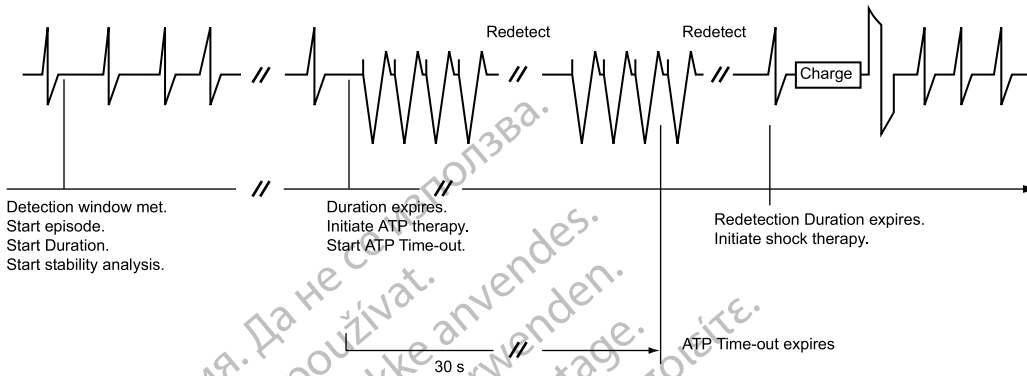

Figure 3-19. ATP Time-out expiration

NOTE: Once a ventricular shock has been delivered during a ventricular episode, ATP will no longer be invoked, irrespective of the time remaining on the ATP Time-out timer.

The timer alone does not invoke therapy; the rate and duration criteria and detection enhancements must still be satisfied in order for a shock therapy to be delivered.

If three zones are programmed, you may program ATP Time-out settings in each of the lower two ventricular zones (Figure 3-20 ATP Time-outs, 3-zone configuration on page 3-14).

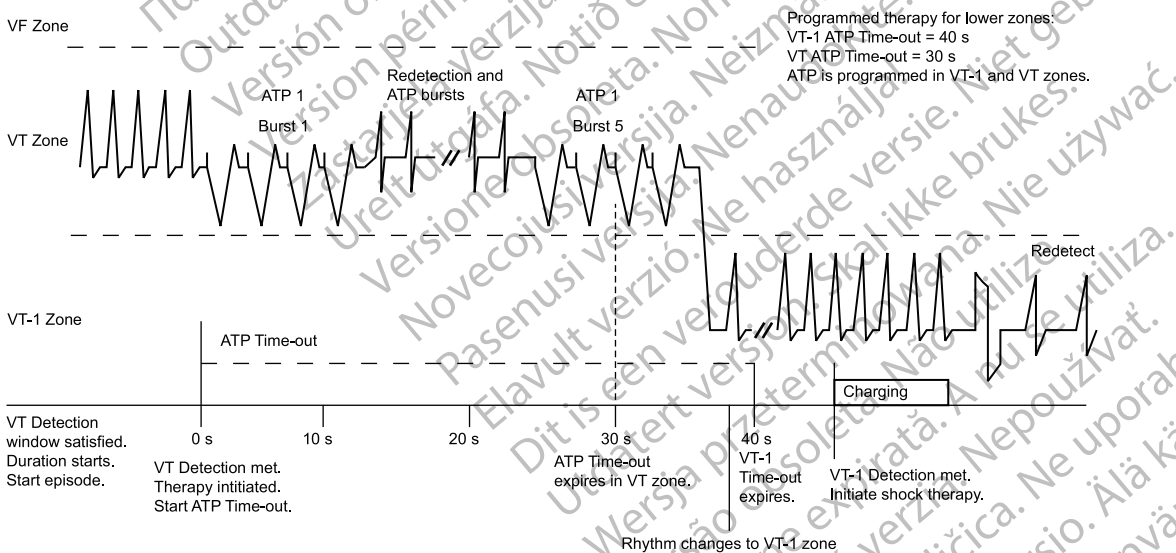

Figure 3-20. ATP Time-outs, 3-zone configuration

QUICK CONVERT ATP

The programmable rate QUICK CONVERT ATP feature is available in AUTOGEN and DYNAGEN devices. The non-programmable rate QUICK CONVERT ATP feature is available in INOGEN, INCEPTA, ENERGEN, and COGNIS devices.

QUICK CONVERT ATP provides an additional option to treat a fast, monomorphic VT that is detected in the VF zone, before advancing to shock therapy.

When QUICK CONVERT ATP is programmed to On, the pulse generator delivers one burst of ATP consisting of 8 pacing pulses with an 88% Coupling Interval and 88% BCL.

QUICK CONVERT ATP is used only as the first therapy attempted in an episode. In the event that QUICK CONVERT ATP is unsuccessful in converting the rhythm and shock therapy is required, the feature's algorithm minimizes the delay to begin charging by using reconfirmation to evaluate whether ATP therapy successfully treated the arrhythmia:

- If 2 out of 3 intervals following delivery of QUICK CONVERT ATP are faster than the lowest rate threshold, the attempt is considered unsuccessful and charging begins for a non-committed shock.
- If 2 out of 3 intervals are slow, shock therapy is diverted and the pulse generator enters redefection. If redetection is satisfied following a diverted shock, the next shock will be committed.

NOTE: QUICK CONVERT ATP is not applied to any rhythm above the programmed maximum rate (250 or 300 min⁻¹). For models with non-programmable rate QUICK CONVERT ATP, the programmable option of On is equivalent to a rate of 250 min⁻¹.

NOTE: QUICK CONVERT ATP is delivered BiV. The LV Pace will be delivered synchronous to the RV Pace regardless of the LV Offset.

VENTRICULAR SHOCK THERAPY AND PARAMETERS

The pulse generator delivers shocks synchronous to a sensed event. The shock vector, energy level, and polarity of the shocks are programmable.

Ventricular Shock Vector

This feature is available in AUTOGEN, DYNAGEN, INOGEN, ORIGEN, INCEPTA, ENERGEN, PUNCTUA, and COGNIS devices.

The programmed Ventricular Shock Vector indicates the vector of energy delivery for ventricular shock therapy.

The following programmable configurations are available:

- RV Coil to RA Coil and Can—this vector is also known as the V-TRIAD vector. It uses the metallic housing of the pulse generator as an active electrode (“hot can”) combined with a two-electrode defibrillation lead. Energy is sent via a dual-current pathway from the distal shocking electrode to the proximal electrode and to the pulse generator case.
- RV Coil to Can—this vector uses the metallic housing of the pulse generator as an active electrode (“hot can”). Energy is sent from the distal shocking electrode to the pulse generator case. This configuration should be selected when using a single-coil lead.
- RV Coil to RA Coil—this vector removes the pulse generator case as an active electrode and is also known as a “cold can” vector. Energy is sent from the distal shocking electrode to the proximal electrode. This vector should never be used with a single-coil lead, as a shock will not be delivered.

Ventricular Shock Energy

This feature is available in AUTOGEN, DYNAGEN, INOGEN, ORIGEN, INCEPTA, ENERGEN, PUNCTUA, and COGNIS devices.

Ventricular shock energy determines the strength of shock therapy delivered by the pulse generator.

Shock output remains constant over the lifetime of the pulse generator, regardless of changes in lead impedance or battery voltage. The constant output is accomplished by varying pulse width to adjust to changes in lead impedance.

The first two shocks in each ventricular zone can be programmed to optimize charge time, longevity, and safety margins. The remaining shock energies in each zone are nonprogrammable at the maximum-energy value.

Charge Time

Charge Time is the time the pulse generator requires to charge for delivery of the programmed shock energy.

Charge Time is dependent on the following:

- Programmed output energy level
- Battery condition
- Condition of the energy storage capacitors

Charge times increase as the pulse generator is programmed to higher energy output levels and as the battery depletes (Table 3–1 Typical charge time required at 37 degrees C at the beginning of life on page 3-16). If a charge time is greater than 15 seconds, the pulse generator schedules an automatic capacitor re-formation for one hour later. If the charge time during re-formation also exceeds 15 seconds, battery status is changed to Explant.

Capacitor deformation can occur during inactive periods and may result in a slightly longer charge time. To reduce the impact of capacitor deformation on charge time, the capacitors are automatically reformed.

Table 3–1. Typical charge time required at 37 degrees C at the beginning of life

Energy Stored (J) ^a	Energy Delivered (J) ^b	Charge Time (seconds) ^c
11.0	10.0	1.9
17.0	15.0	3.0 (AUTOGEN, DYNAGEN, INOGEN, ORIGEN) 3.0 (INCEPTA, ENERGEN, PUNCTUA) 2.9 (COGNIS)
26.0	22.0	4.8 (AUTOGEN, DYNAGEN, INOGEN, ORIGEN) 4.8 (INCEPTA, ENERGEN, PUNCTUA) 4.7 (COGNIS)
41.0 ^d	35.0	8.1 (AUTOGEN, DYNAGEN, INOGEN, ORIGEN) 8.8 (INCEPTA, ENERGEN, PUNCTUA) 8.4 (COGNIS)

a. Values indicate the energy level stored on the capacitors and correspond to the value programmed for shock energy parameters.

b. The energy delivered indicates the shock energy level delivered through the shocking electrodes.

c. Charge times shown are at beginning of life after capacitor re-formation.

d. HE.

Table 3–2. Typical maximum-energy charge time over the life of AUTOGEN, DYNAGEN, INOGEN, and ORIGEN pulse generators

Charge Remaining (Ah) ^a	Maximum-energy Charge Time Range (seconds)
2.1 to 1.0	8 to 10
1.0 to 0.4	9 to 12
0.4 to 0.2	10 to 14

a. At explant, Charge Remaining is typically 0.18 Ah, and residual capacity is 0.15 Ah. These may vary depending on the amount of therapy delivered over the life of the pulse generator. Residual capacity is used to support device function between Explant and Battery Capacity Depleted indicators.

Table 3–3. Typical maximum-energy charge time over the life of INCEPTA, ENERGEN, and PUNCTUA pulse generators

Charge Remaining (Ah) ^a	Maximum-energy Charge Time Range (seconds)
2.1 to 1.0	8 to 10
1.0 to 0.4	10 to 12
0.4 to 0.3	11 to 13

a. At explant, Charge Remaining is typically 0.22 Ah, and residual capacity is 0.17 Ah. These may vary depending on the amount of therapy delivered over the life of the pulse generator. Residual capacity is used to support device function between Explant and Battery Capacity Depleted indicators.

Table 3–4. Typical maximum-energy charge time over the life of COGNIS pulse generators

Charge Remaining (Ah) ^a	Maximum-energy Charge Time Range (seconds)
2.1 to 1.0	7 to 10
1.0 to 0.4	8 to 12
0.4 to 0.3	10 to 14

a. At explant, Charge Remaining is typically 0.22 Ah, and residual capacity is 0.16 Ah. These may vary depending on the amount of therapy delivered over the life of the pulse generator. Residual capacity is used to support device function between Explant and Battery Capacity Depleted indicators.

NOTE: The maximum-energy charge time ranges above are based upon theoretical electrical principles and verified bench testing only.

Waveform Polarity

This feature is available in AUTOGEN, DYNAGEN, INOGEN, ORIGEN, INCEPTA, ENERGEN, PUNCTUA, and COGNIS devices.

Waveform polarity reflects the relationship between the leading edge voltages on the defibrillating output electrodes. All shocks will be delivered using a biphasic waveform (Figure 3–21 Biphasic waveform on page 3-18).

- For AUTOGEN, DYNAGEN, INOGEN, and ORIGEN devices, the peak shock voltage (V1) is 728 V at 41 J, 531 V at 21 J, and 51 V at 0.1 J.
- For INCEPTA, ENERGEN, PUNCTUA, and COGNIS devices, the peak shock voltage (V1) is 750 V at 41 J, 535 V at 21 J, and 37 V at 0.1 J.

The selection of the shock polarity applies to all shocks delivered by the device. If the preceding shocks in a zone are unsuccessful, the last shock of that zone will be automatically delivered at an inverted polarity to the previous shock (initial or reversed) (Figure 3–22 Polarity of shock delivery on page 3-18).

CAUTION: For IS-1/DF-1 leads, never change the shock waveform polarity by physically switching the lead anodes and cathodes in the pulse generator header—use the programmable Polarity feature. Device damage or nonconversion of the arrhythmia post-operatively may result if the polarity is switched physically.

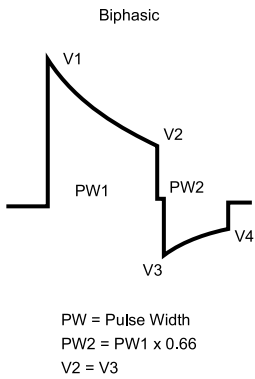

Figure 3-21. Biphasic waveform

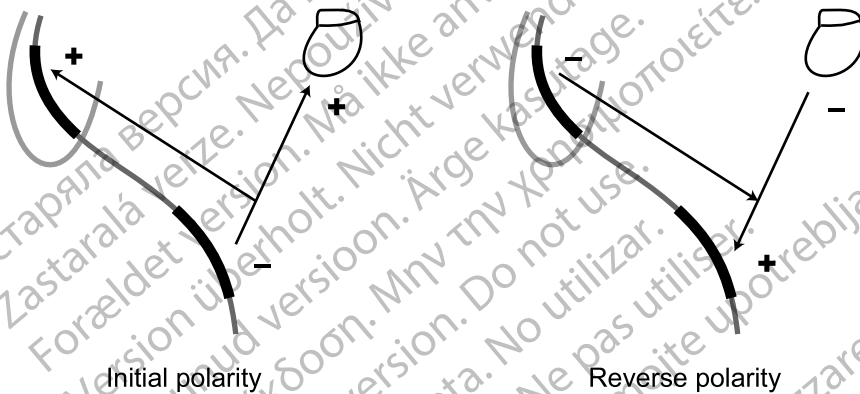

Figure 3-22. Polarity of shock delivery

Committed Shock/Reconfirmation of the Ventricular Arrhythmia

This feature is available in AUTOGEN, DYNAGEN, INOGEN, ORIGEN, INCEPTA, ENERGEN, PUNCTUA, and COGNIS devices.

Committed Shock/Reconfirmation refers to the monitoring performed by the pulse generator before delivery of a ventricular shock.

If the patient is subject to non-sustained arrhythmias, reconfirmation may be desirable in order to prevent delivery of unnecessary shocks to the patient.

The device monitors tachyarrhythmias during and immediately following capacitor charging. During this time, it checks for the spontaneous conversion of the tachyarrhythmia and determines whether ventricular shock therapy should be delivered; it does not affect therapy selection.

Ventricular shock therapy can be programmed as committed or non-committed. If the Committed Shock feature is programmed to On, the shock is delivered synchronously with the first sensed R-wave following a 500-ms delay after the capacitors are charged, whether the arrhythmia is sustained or not (Figure 3-23 Committed Shock is programmed to On, Reconfirmation is Off on page 3-19). The 500-ms delay allows a minimum time for a divert command to be issued from the PRM, if desired. If there is no sensed R-wave detected within 2 seconds following the end of charging, the ventricular shock is delivered asynchronously at the end of the 2-second interval.

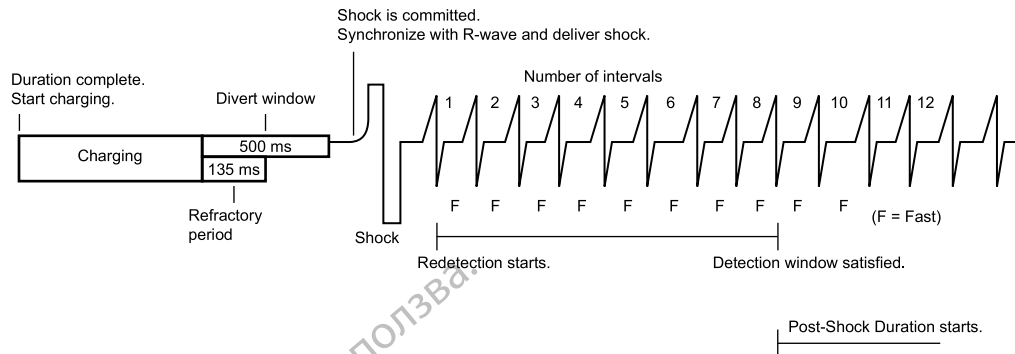

Figure 3-23. Committed Shock is programmed to On, Reconfirmation is Off

NOTE: There is a forced 135-ms refractory period following the end of charging; events that occur during the first 135 ms of the 500-ms delay are ignored.

If the Committed Shock feature is programmed to Off, Reconfirmation consists of the following steps:

1. During capacitor charging, the pulse generator continues to sense the arrhythmia. Sensed and paced beats are evaluated. If 5 slow beats (sensed or paced) are counted in a 10-beat detection window (or 4 consecutive slow beats after an unsuccessful QUICK CONVERT ATP attempt), the pulse generator stops charging and considers this a Diverted-Reconfirm.
2. If 5 of 10 beats are not detected as slow (or less than 4 consecutive slow beats after an unsuccessful QUICK CONVERT ATP attempt) and charging completes, post-charge reconfirmation is performed after charging ends. After the post-charge refractory and the first sensed event, the pulse generator measures up to 3 intervals following charging and compares them to the lowest rate threshold.
 - If 2 of the 3 intervals following charging are faster than the lowest rate threshold, the shock will be delivered synchronously with the second fast event.
 - If 2 of the 3 intervals following charging are slower than the lowest rate threshold, the shock will not be delivered. If no beats are sensed, pacing will begin at the programmed LRL following the 2-second no-sense period. If a shock is not delivered, or if pacing pulses are delivered, this is also considered a Diverted-Reconfirm.

If a shock is required after redetection, the charge time for the shock may be short.

The reconfirmation algorithm will not allow two consecutive Diverted-Reconfirm cycles. If the arrhythmia is detected after a Diverted-Reconfirm, the next shock in the episode is delivered as if Committed Shock were programmed to On. Once a shock has been delivered, the reconfirmation algorithm can be applied again (Figure 3-24 Committed Shock is programmed to Off, reconfirmation is On on page 3-19).

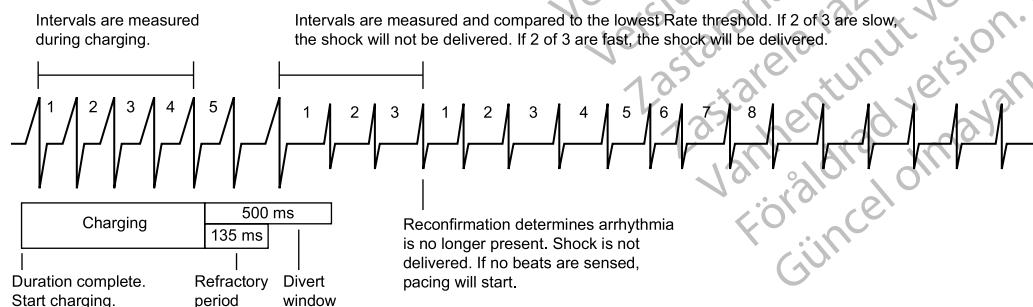

Figure 3-24. Committed Shock is programmed to Off, reconfirmation is On

Остаряла версия. Да не се използва.
Zastaralá verze. Nepoužívat.
Forældet version. Må ikke anvendes.
Version überholt. Nicht verwenden.
Aegunud versioón. Äрге kasutage.
Παλιά έκδοση. Μην την χρησιμοποιείτε.
Outdated version. Do not use.
Versión obsoleta. No utilizar.
Zastarjela verzija. Nemojte upotrebljavati.
Úreilt útgáfa. Notið ekki.
Versione obsoleta. Ne pas utiliser.
Zastarjela verzija. Nemojte upotrebljavati.
Novecojsi versija. Non utilizzare.
Pasenusi versija. Neizmantot.
Elavult verzió. Ne használja!
Dit is een verouderde versie. Niet gebruiken.
Utdatert versjon. Skal ikke brukes.
Wersja przeterminowana. Nie używać.
Versão obsoleta. Não utilize.
Versione expirată. A nu se utiliza.
Zastaraná verzia. Nepoužívať.
Vanhentunut versio. Älä käytä.
Föråldrad version. Använd ej.
Güncel olmayan sürüm. Kullanmayın.

PACING THERAPIES

CHAPTER 4

This chapter contains the following topics:

- “Pacing Therapies” on page 4-2
- “Device Programming Recommendations” on page 4-3
- “Maintaining CRT” on page 4-4
- “Basic Parameters” on page 4-5
- “Post-Therapy Pacing” on page 4-28
- “Temporary Brady Pacing” on page 4-29
- “Rate Adaptive Pacing and Sensor Trending” on page 4-30
- “Atrial Tachy Response” on page 4-46
- “Rate Enhancements” on page 4-52
- “Lead Configuration” on page 4-57
- “AV Delay” on page 4-61
- “Refractory” on page 4-66
- “Noise Response” on page 4-75
- “Ventricular Tachy Sensing Interactions” on page 4-77

PACING THERAPIES

CRT-Ds provide both atrial and biventricular normal and post-therapy bradycardia pacing, including adaptive-rate modes.

WARNING: During MRI Protection Mode, if Brady Mode is programmed to Off, Bradycardia therapy and Cardiac Resynchronization Therapy (CRT) are suspended. The patient will not receive pacing until the pulse generator is programmed back to normal operation. Only program Brady Mode to Off during MRI Protection Mode and scan the patient if judged to be clinically capable of tolerating no Bradycardia therapy (including pacing-dependence or need for overdrive pacing) and no CRT for the entire duration in which the pulse generator is in MRI Protection Mode.

The bradycardia pacing function is independent of the tachycardia detection and therapy functions of the device, with the exception of interval-to-interval sensing.

The pulse generator provides the following types of therapies:

CRT

- When the patient's intrinsic atrial rate is below the MTR and the programmed AV Delay is less than the intrinsic intracardiac AV interval, the device delivers pacing pulses to the ventricles at the programmed settings in order to synchronize ventricular contractions.
- Independent programmability of the RV and LV leads allows therapeutic flexibility for restoring mechanical coordination.

NOTE: For CRT and bradycardia therapy decisions, the cardiac cycle is determined by RV sensed and paced events or LV paced events when the pacing chamber is programmed to LV Only. It is necessary that an RV lead be implanted even when programmed to LV-only pacing because all of the device timing cycles rely on the RV. LV sensed events inhibit inappropriate LV pacing and do not modify the timing cycle.

CAUTION: To ensure a high percentage of biventricular pacing, the programmed AV Delay setting must be less than the patient's intrinsic PR interval.

Normal Bradycardia Pacing

- If the intrinsic heart rate falls below the programmed pacing rate (i.e., LRL), the device delivers pacing pulses at the programmed settings.
- Adaptive-rate pacing allows the pulse generator to adapt the pacing rate to the patient's changing activity levels and/or physiologic needs.

Post-Therapy Pacing—alternative bradycardia pacing therapy may be delivered for a programmed period to ensure capture after delivery of a shock.

Additional Options

- Temporary Bradycardia Pacing—allows the clinician to examine alternate therapies while maintaining the previously programmed normal pacing settings in the pulse generator memory ("Temporary Brady Pacing" on page 4-29).
- STAT PACE—initiates emergency ventricular pacing at high output settings when commanded via the PRM using telemetry communication ("STAT PACE" on page 1-17).

DEVICE PROGRAMMING RECOMMENDATIONS

It is important to program device parameters to the appropriate settings to ensure optimal CRT delivery. Please consider the following guidelines in conjunction with the patient's specific condition and therapy needs.

NOTE: Also consider using *Indications-Based Programming (IBP)*, a tool that provides specific programming recommendations based on the patient's clinical needs and primary indications ("Indications-Based Programming" on page 1-14).

CAUTION: Programming the device to provide RV-only pacing is not intended for the treatment of heart failure. The clinical effects of RV-only pacing for the treatment of heart failure have not been established.

Pacing mode—Program a dual-chamber tracking mode [VDD(R) or DDD(R)]. Adaptive-rate pacing modes are intended for patients who exhibit chronotropic incompetence and who would benefit by increased pacing rates concurrent with physical activity ("Brady Mode" on page 4-6).

Pacing chamber—Program to BiV (nominal) unless medical discretion dictates the selection of a different pacing chamber ("Ventricular Pacing Chamber" on page 4-12).

BiV Trigger—Program to On to provide biventricular pacing up to the applicable upper rate limit.

LRL—Program below a sinus rate normally reached while still providing an appropriate rate for bradycardia support ("Lower Rate Limit" on page 4-8). If the pulse generator is programmed to VVI(R) mode and the patient has AV conduction during atrial tachyarrhythmias, resulting in inhibition of biventricular pacing (loss of CRT), consider programming an elevated LRL to increase the delivery of biventricular pacing.

MTR—Program high enough to ensure 1:1 AV synchrony. A MTR at 130 min^{-1} is recommended unless medical discretion dictates otherwise ("Maximum Tracking Rate" on page 4-9).

Pacing Output—The programmed Amplitude is recommended to be a minimum of 2X the capture threshold to provide adequate safety margin. Lower pace amplitudes will preserve/extend longevity. The programmed Amplitude should be a balance of adequate safety margin and effect upon battery longevity. If PaceSafe is programmed On, it will automatically provide an adequate safety margin and may help extend battery longevity ("PaceSafe" on page 4-14).

Paced AV Delay—The Paced AV Delay setting should be individualized for each patient to ensure consistent CRT delivery. Several methods are available to determine the Paced AV Delay setting, including:

- Intrinsic QRS duration assessment
- Echocardiogram
- Pulse pressure monitoring
- SmartDelay optimization, which will recommend AV Delay settings ("SmartDelay Optimization" on page 4-64)

Since optimizing the Paced AV Delay can significantly influence CRT effectiveness, consider using methods that demonstrate the hemodynamic impact of different Paced AV Delay settings, such as echocardiography or pulse pressure monitoring.

Atrial pacing may prolong the interatrial delay; therefore, it may be necessary to program different Paced AV Delay settings to optimize CRT during normal sinus rhythm and atrial pacing.

Sensed AV Delay—Sensed AV Delay is used to achieve a shorter AV Delay following sensed atrial events while the longer, programmed Paced AV Delay is used following paced atrial events.

When programmed to the DDD(R) mode, it is recommended that the patient be tested to determine the optimal Sensing AV Delay during atrial sensing and pacing.

Dynamic AV Delay—Dynamic AV Delay is set automatically based on the following ("Paced AV Delay" on page 4-61):

- If the minimum and maximum Paced AV Delays are equal, then AV Delay is fixed.
- If the minimum Paced AV Delay is less than the maximum, then AV Delay is set to Dynamic.

PVARP—Program PVARP to 280 ms. For heart failure patients with intact AV conduction, a long intrinsic intracardiac AV interval and a long programmed PVARP can cause a loss of atrial tracking below the MTR, resulting in a loss of BiV stimulation (CRT). If loss of atrial tracking below the MTR is occurring, program Tracking Preference to On (nominal) ("A-Refractory - PVARP" on page 4-66).

PVARP after PVC—Program PVARP after PVC to 400 ms (nominal) to potentially reduce the number of PMTs at high rates. The occurrence of PMTs may also be due to other factors ("PVARP after PVC" on page 4-68).

ATR—If ATR is used, Entry and Exit Counts should be programmed to ensure appropriate and timely mode switching ("ATR Mode Switch" on page 4-46).

Note that VRR and BiV Trigger have the potential to increase CRT delivery during atrial tachyarrhythmias. BiV Trigger should be programmed to On, and VRR should be programmed to On at the maximum setting to increase the percent of ventricular pacing and maximize consistent CRT delivery during conducted atrial tachyarrhythmias.

PMT Termination—Program to On (nominal) to terminate PMTs at high rates ("PMT Termination" on page 4-51).

LVPP—Program to 400 ms (nominal) to prevent the device from pacing in the LV vulnerable period ("Left Ventricular Protection Period" on page 4-70).

Tracking Preference—Program to On (nominal) to support CRT delivery for atrial rates below, but near, the MTR. Use this feature when PVARP and the patient's intrinsic intracardiac AV interval are longer than the programmed MTR interval ("Tracking Preference" on page 4-52).

LV Lead Configuration—For devices with an IS-1 or LV-1 left ventricular lead port, program in accordance with the number of electrodes on the LV lead ("Left Ventricular Electrode Configuration" on page 4-57).

MAINTAINING CRT

Certain conditions may cause the temporary loss of CRT or AV synchrony due to Wenckebach-like behavior, and heart failure patients may become symptomatic if CRT is compromised. Please consider the following when you are programming the device.

MTR

Rapid atrial rates with a fast ventricular response above MTR can cause:

- Temporary inhibition of CRT if AV conduction is intact
- Wenckebach-like behavior if second- or third-degree AV block is present

CRT delivery and programmed AV synchrony return when normal sinus rates are restored.

MTR should be programmed sufficiently high to maintain CRT at fast atrial rates. In addition, please consider the following for maintaining CRT:

- Rate Smoothing may be used to prevent sudden changes in rate
- VRR may help promote CRT by increasing the percent of ventricular pacing during conducted atrial arrhythmias
- SVTs may require medical management to preserve CRT as well as protect the patient from the potential hemodynamic compromise associated with fast rates
- Medical management of fast atrial rates can maximize the amount of time that the patient remains below MTR and help ensure consistent CRT delivery

NOTE: *If a patient has slow VT, the ability to program higher MTR values is limited by the lower rate threshold of the lowest tachyarrhythmia zone.*

For CRT delivery at heart rates that correspond to the slow VT rate, consider managing the slow VT by alternate means such as antiarrhythmic drugs or catheter ablation to ensure consistent CRT.

AFR

AFR may delay or inhibit an atrial paced event and prevent pacing into the atrial vulnerable period and provide immediate cessation of tracking of atrial rates higher than the AFR programmable rate. This changes the AV Delay and may impact CRT effectiveness if the AFR rate is programmed slower than the patient's sinus rate.

Rate Smoothing

When Rate Smoothing Up is programmed to On, CRT is compromised during episodes of atrial rate increases exceeding the programmed Rate Smoothing Up percentage. For patients with AV block, this occurs because Rate Smoothing Up prolongs AV Delay from the optimal setting (controls the biventricular pacing rate while the atrial rate increases).

Features that Switch to VVI or VVI-like Behavior

VTR/ATR may result in Wenckebach-like behavior or the temporary loss of CRT. CRT delivery with programmed AV synchrony will return when the SVT/VT/VE event is resolved and a normal sinus rhythm is restored.

For patients programmed to VDD(R) with sinus rates below LRL, CRT will not be synchronized with atrial events and loss of AV synchrony will result. Consider programming a lower LRL or enabling a pacing mode that provides atrial pacing with synchronous ventricular pacing [e.g., DDD(R)], as medically appropriate.

STAT PACE delivers CRT in VVI mode with a loss of AV synchrony. The permanent, programmed settings resume when the pulse generator is programmed out of STAT PACE.

BASIC PARAMETERS

By programming device parameters, the pulse generator provides CRT for the intent of providing mechanical synchronization. The programming options used for CRT include those used for bradycardia pacing therapy.

LV stimulation is delivered using a unipolar or bipolar LV lead. The device uses atrial pacing and sensing to coordinate AV contractions with CRT.

Normal Settings include the following:

- Pacing parameters, which are independently programmable from post-therapy and temporary pacing parameters

- Pacing and Sensing
- Leads
- Sensors and Trending

Post-Therapy Settings include the following:

- Pacing parameters, which are independently programmable from normal and temporary pacing parameters
- Post-ventricular shock

Interactive Limits

Because many features with programmable parameters interact, programmed values must be compatible across such features. When values requested by the user are incompatible with existing parameters, the programmer screen displays an alert describing the incompatibility and either prohibits the selection or instructs the user to proceed with caution ("Use of Color" on page 1-7).

Brady Mode

This feature is available in AUTOGEN, DYNAGEN, INOGEN, ORIGEN, INCEPTA, ENERGEN, PUNCTUA, and COGNIS devices.

Brady modes provide programmable options to help individualize patient therapy.

This pulse generator includes the pacing modes identified in the Programmable Options appendix.

CRT Modes

The objective of CRT is to deliver continuous pacing to the ventricles. CRT can only be delivered in modes that provide ventricular pacing.

The maximal CRT benefit can be achieved when biventricular stimulation is delivered. Atrial pacing and adaptive-rate modes may be appropriate for patients who also experience bradycardia.

WARNING: Do not use atrial-only modes in patients with heart failure because such modes do not provide CRT.

NOTE: *The safety and effectiveness of CRT was evaluated in clinical studies using the VDD mode. Use medical discretion when programming the pulse generator to pacing modes other than VDD.*

NOTE: *Atrial pacing may prolong interatrial conduction, desynchronizing right and left atrial contractions. The effect of atrial pacing on CRT has not been studied.*

DDD and DDDR

In the absence of sensed P- and R-waves, pacing pulses will be delivered to the atrium and the ventricle at the LRL (DDD) or the sensor-indicated rate (DDDR), separated by the AV Delay. A sensed P-wave will inhibit an atrial pace and start the AV Delay. At the end of the AV Delay, a ventricular pace will be delivered unless inhibited by a sensed R-wave.

- Could be appropriate for heart failure patients with sinus bradycardia since DDD(R) can provide atrial-synchronous biventricular pacing at rates above the LRL and AV-sequential biventricular pacing at the LRL or sensor-indicated rate—DDDR

- DDD mode may be preferred over VDD mode for patients with sinus bradycardia or atrial rates below the LRL to preserve AV synchrony with CRT delivery

DDI and DDIR

In the absence of sensed P- and R-waves, pacing pulses will be delivered to the atrium and the ventricle at the LRL (DDI) or the sensor-indicated rate (DDIR), separated by the AV Delay. A sensed P-wave will inhibit an atrial pace but will not start the AV Delay.

- May not be appropriate for heart failure patients with normal sinus activity
- Could be appropriate for heart failure patients who have no underlying intrinsic sinus rhythm but might experience episodes of atrial tachyarrhythmias such as brady-tachy syndrome
- Provide AV-sequential biventricular pacing only at the LRL (DDI) or sensor-indicated rate (DDIR) in the absence of sinus activity
- During periods of intrinsic atrial activity above the LRL and in the absence of sensed R-waves, non-atrial-synchronous biventricular pacing is delivered at the LRL or sensor-indicated rate

VDD and VDDR

In the absence of sensed P- and R-waves, pacing pulses will be delivered to the ventricle at the LRL (VDD) or the sensor-indicated rate (VDDR). A sensed P-wave will start the AV Delay. At the end of the AV Delay, a ventricular pace will be delivered unless inhibited by a sensed R-wave. A sensed R-wave or a paced ventricular event will determine the timing of the next ventricular pace.

- VDD is appropriate for heart failure patients with normal sinus activity, since VDD delivers atrial-synchronous biventricular pacing but no atrial pacing
- VDDR may not be appropriate for heart failure patients with normal sinus activity due to the increased potential for loss of AV synchrony
- While VDDR can provide atrial-synchronous biventricular pacing during normal sinus activity, sensor-driven ventricular pacing will result in the loss of AV synchrony if the sensor-indicated rate exceeds the sinus rate
- Consider programming a low LRL for bradycardia support since loss of AV synchrony is likely to occur during LRL ventricular pacing
- If frequent pacing at the LRL is anticipated or observed, consider programming a DDD(R) mode to maintain AV synchrony during LRL pacing

VVI and VVIR

In VVI(R) mode, sensing and pacing occur only in the ventricle. In the absence of sensed events, pacing pulses will be delivered to the ventricle at the LRL (VVI) or the sensor-indicated rate (VVIR). A sensed R-wave or a paced ventricular event will determine the timing of the next ventricular pace.

- May be detrimental for heart failure patients with normal sinus activity
- Could be appropriate for heart failure patients with chronic atrial tachyarrhythmias or during episodes of atrial tachyarrhythmia since they provide biventricular pacing at the LRL or sensor-indicated rate—VVI(R)

- If patients have AV conduction during atrial tachyarrhythmias that results in inhibition of biventricular pacing (loss of CRT), consider programming an elevated LRL in an attempt to increase the delivery of biventricular pacing and/or to VVI(R), if not already programmed

AAI and AAIR

In AAI(R) mode, sensing and pacing occur only in the atrium. In the absence of sensed events, pacing pulses will be delivered to the atrium at the LRL (AAI) or the sensor-indicated rate (AAIR). A sensed P-wave or a paced atrial event will determine the timing of the next atrial pace.

Dual-Chamber Modes

Do not use DDD(R) and VDD(R) modes in the following situations:

- In patients with chronic refractory atrial tachyarrhythmias (atrial fibrillation or flutter), which may trigger ventricular pacing
- In the presence of slow retrograde conduction that induces PMT, which cannot be controlled by reprogramming selective parameter values

Atrial Pacing Modes

In DDD(R), DDI(R), and AAI(R) modes, atrial pacing may be ineffective in the presence of chronic atrial fibrillation or flutter or in an atrium that does not respond to electrical stimulation. In addition, the presence of clinically significant conduction disturbances may contraindicate the use of atrial pacing.

WARNING: Do not use atrial tracking modes in patients with chronic refractory atrial tachyarrhythmias. Tracking of atrial arrhythmias could result in ventricular tachyarrhythmias.

NOTE: Refer to "Use of Atrial Information" on page 2-6 for additional information about device performance when the atrial lead is programmed to Off.

If you have any questions regarding the individualization of patient therapy, contact Boston Scientific using the information on the back cover.

Lower Rate Limit (LRL)

This feature is available in AUTOGEN, DYNAGEN, INOGEN, ORIGEN, INCEPTA, ENERGEN, PUNCTUA, and COGNIS devices.

LRL is the number of pulses per minute at which the pulse generator paces in the absence of sensed intrinsic activity.

As long as the ventricle is being paced (or if a PVC occurs), the interval is timed from one ventricular event to the next. Whenever an event is sensed in the ventricle (e.g., intrinsic AV conduction occurs before the AV Delay elapses), the timing base switches from ventricular-based timing to modified atrial-based timing (Figure 4-1 LRL timing transitions on page 4-9). This switching of timing base ensures accurate pacing rates since the difference between the intrinsic AV conduction and programmed AV Delay is applied to the next V-A interval.

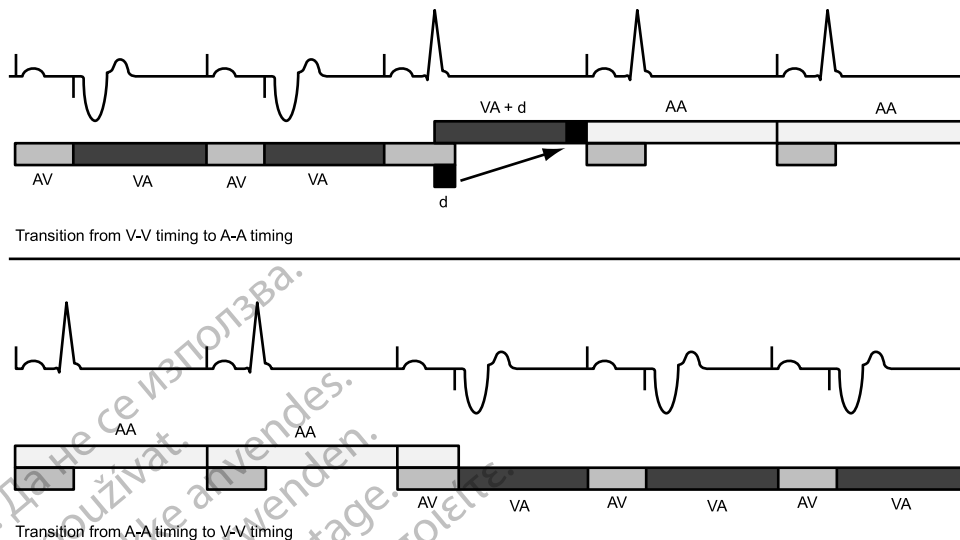

Illustration of timing transitions (d = the difference between AV Delay and the AV interval in the first cycle during which intrinsic conduction occurs. The value of d is applied to the next V–A interval to provide a smooth transition without affecting A–A intervals).

Figure 4-1. LRL timing transitions

Maximum Tracking Rate (MTR)

This feature is available in AUTOGEN, DYNAGEN, INOGEN, ORIGEN, INCEPTA, ENERGEN, PUNCTUA, and COGNIS devices.

The MTR is the maximum rate at which the paced ventricular rate tracks 1:1 with nonrefractory sensed atrial events in the absence of a sensed ventricular event within the programmed AV Delay. MTR applies to atrial synchronous pacing modes, namely DDD(R) and VDD(R).

Consider the following when programming MTR:

- The patient's condition, age, and general health
- The patient's sinus node function
- A high MTR may be inappropriate for patients who experience angina or other symptoms of myocardial ischemia at higher rates

NOTE: If the pulse generator is operating in DDDR or VDDR mode, the MSR and MTR may be programmed independently to different values.

Upper Rate Behavior

For heart failure patients with normal AV conduction, biventricular stimulation (CRT) may not be delivered when the atrial rate exceeds the MTR. This can occur if the AV Delay lengthens beyond the patient's intrinsic intracardiac AV interval and AV conduction occurs, which inhibits ventricular pacing. In both situations (AV block and AV conduction) CRT is compromised when the atrial rate exceeds the MTR, either because of the suboptimal, prolonged AV Delay or a loss of biventricular pacing, or both.

If the patient's normal atrial rate exceeds the MTR, consider programming a higher MTR to ensure 1:1 atrial synchronous, biventricular pacing at the programmed AV Delay. If reprogramming a higher MTR is limited by the current TARP (AV Delay + PVARP = TARP), attempt to shorten the PVARP before shortening the AV Delay in order to avoid a suboptimal AV Delay for CRT.

When the sensed atrial rate is between the programmed LRL and MTR, 1:1 ventricular pacing will occur in the absence of a sensed ventricular event within the programmed AV Delay. If the sensed atrial rate exceeds the MTR, the pulse generator begins a Wenckebach-like behavior to prevent the paced ventricular rate from exceeding the MTR. This Wenckebach-like behavior is characterized by a progressive lengthening of the AV Delay until an occasional P-wave is not tracked because it falls into the PVARP. This results in an occasional loss of 1:1 tracking as the pulse generator synchronizes its paced ventricular rate to the next sensed P-wave. Should the sensed atrial rate continue to increase further above the MTR, the ratio of sensed atrial events to sequentially paced ventricular events becomes lower until, eventually, 2:1 block results (e.g., 5:4, 4:3, 3:2, and finally 2:1).

The sensing window should be maximized by programming the appropriate AV Delay and PVARP. At rates close to the MTR, the sensing window can be maximized by programming Dynamic AV Delay and Dynamic PVARP, and Wenckebach behavior will be minimized.

High rate atrial tracking is limited by the programmed MTR and the total atrial refractory period (TARP) ($AV\ Delay + PVARP = TARP$). In order to avoid complete closure of the sensing window at MTR, the PRM will not allow a TARP interval that is longer (lower pacing rate) than the programmed MTR interval.

If the TARP interval is shorter (higher pacing rate) than the interval of the programmed MTR, then the pulse generator's Wenckebach-like behavior limits the ventricular pacing rate to the MTR. If the TARP interval is equal to the interval of the programmed MTR, 2:1 block may occur with atrial rates above the MTR.

Rapid changes in the paced ventricular rate (e.g., Wenckebach-like, 2:1 block) caused by sensed atrial rates above the MTR may be dampened or eliminated by the implementation of any of the following:

- AFR
- ATR
- Rate Smoothing parameters and sensor input

NOTE: For the purpose of atrial tachycardia detection and histogram updates, atrial events are detected throughout the cardiac cycle (except during atrial blanking), including AV Delay and PVARP.

Examples

If the atrial rate exceeds the MTR, the AV Delay will be progressively lengthened (AV') until an occasional P-wave is not tracked because it falls into the atrial refractory period (Figure 4–2 Wenckebach behavior at MTR on page 4-10). This results in occasional loss of 1:1 tracking as the pulse generator synchronizes its paced ventricular rate to the next tracked P-wave (pacemaker Wenckebach).

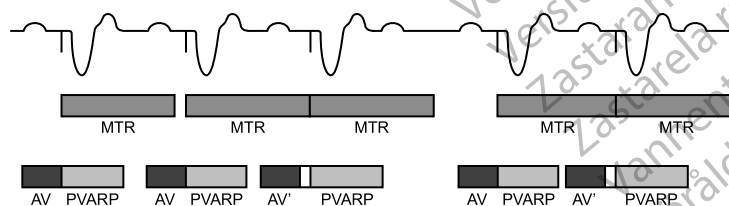

Figure 4–2. Wenckebach behavior at MTR

Another type of pulse generator upper rate behavior (2:1 block) can occur when tracking high atrial rates. In this type of behavior, every other intrinsic atrial event occurs during PVARP and,

thus, is not tracked (Figure 4–3 Pacemaker 2:1 block on page 4-11). This results in a 2:1 ratio of atrial-to-ventricular events or a sudden drop in the ventricular paced rate to half of the atrial rate. At faster atrial rates, several atrial events can fall in the TARP period, resulting in the pulse generator tracking only every third or fourth P-wave. The block then occurs at rates such as 3:1 or 4:1.

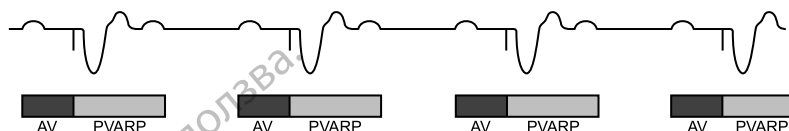

Illustration of pacemaker 2:1 block, in which every other P-wave falls inside the PVARP interval.

Figure 4–3. Pacemaker 2:1 block

Maximum Sensor Rate (MSR)

This feature is available in AUTOGEN, DYNAGEN, INOGEN, ORIGEN, INCEPTA, ENERGEN, PUNCTUA, and COGNIS devices.

MSR is the maximum pacing rate allowed as a result of rate-adaptive sensor control.

Consider the following when programming MSR:

- Patient's condition, age, and general health:
 - Adaptive-rate pacing at higher rates may be inappropriate for patients who experience angina or other symptoms of myocardial ischemia at these higher rates
 - An appropriate MSR should be selected based on an assessment of the highest pacing rate that the patient can tolerate well

NOTE: If the pulse generator is operating in DDDR or VDDR mode, the MSR and MTR may be programmed independently to different values.

MSR is independently programmable at, above, or below the MTR. If the MSR setting is higher than the MTR, pacing above the MTR may occur if the sensor rate exceeds the MTR.

Pacing above the MSR (when programmed lower than the MTR) can only occur in response to sensed intrinsic atrial activity.

CAUTION: Adaptive-rate pacing is not limited by refractory periods. A long refractory period programmed in combination with a high MSR can result in asynchronous pacing during refractory periods since the combination can cause a very small sensing window or none at all. Use Dynamic AV Delay or Dynamic PVARP to optimize sensing windows. If you are programming a fixed AV Delay, consider the sensing outcomes.

With intrinsic conduction, the pulse generator maintains the A–A pacing rate by extending the V–A interval. This extension is determined by the degree of difference between the AV Delay and the intrinsic ventricular conduction—often referred to as modified atrial-based timing (Figure 4–4 VA interval extension and MSR on page 4-12).

Pacing without modified atrial-based timing

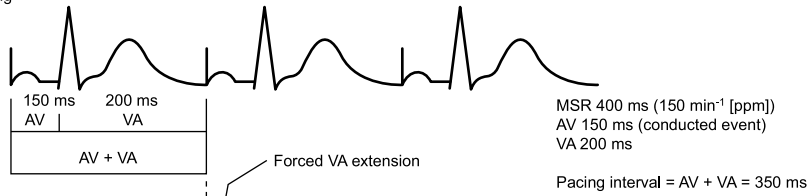

Pacing with modified atrial-based timing



The pulse generator's timing algorithm provides effective pacing at the MSR with intrinsic ventricular conduction. Extending the VA interval prevents the A pace from exceeding the MSR at high rates.

Figure 4-4. VA interval extension and MSR

Runaway Protection

Runaway protection is designed to prevent pacing rate accelerations above the MTR/MSR for most single-component failures. This feature is not programmable and operates independently from the pulse generator's main pacing circuitry.

Runaway protection prevents the pacing rate from increasing above 205 min⁻¹.

NOTE: Magnet application does not affect the pacing rate (pulse interval).

NOTE: Runaway protection is not an absolute assurance that runaways will not occur.

During PES, Manual Burst Pacing, and ATP, runaway protection is temporarily suspended to allow for high-rate pacing.

Ventricular Pacing Chamber

This feature is available in AUTOGEN, DYNAGEN, INOGEN, ORIGEN, INCEPTA, ENERGEN, PUNCTUA, and COGNIS devices.

With the Ventricular Pacing Chamber option, you can choose which chamber(s) will receive pacing pulses.

The following options are available:

- RV Only
- LV Only
- BiV (both RV and LV)—when selected, LV Offset becomes available

NOTE: It is necessary that an RV lead be implanted even when programmed to LV-only pacing because all of the device timing cycles rely on the RV.

For devices with an IS-1 or LV-1 left ventricular lead port, the nominal LV Electrode Configuration is None. This results in a parameter interaction when combined with the nominal Ventricular Pacing Chamber setting of BiV. This is intended to ensure that an appropriate LV Electrode Configuration (dual or single) is chosen based on the implanted LV lead.

For devices with an IS4 left ventricular lead port, the LV Electrode Configuration is automatically set to Quadripolar.

CAUTION: Programming the device to provide RV-only pacing is not intended for the treatment of heart failure. The clinical effects of RV-only pacing for the treatment of heart failure have not been established.

LV Offset

When the Pacing Chamber is set to BiV, the LV Offset feature is available and allows you to adjust the delay between delivery of the left ventricular pacing pulse and the right ventricular pacing pulse. LV Offset is designed to enhance programming flexibility to coordinate the mechanical response of the ventricles.

The device automatically accommodates the LV Offset for high pacing rates (AUTOGEN, DYNAGEN, INOGEN, and ORIGEN devices) and for the lowest programmed tachy rate threshold when biventricular pacing occurs near the upper rate limit.

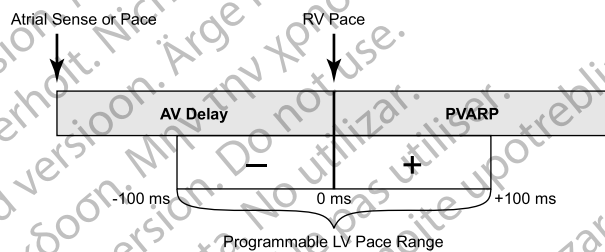

Figure 4-5. Programmable LV pace range

NOTE: The programmed AV Delay is based on RV timing; therefore, it is not affected by LV Offset.

Pulse Width

This feature is available in AUTOGEN, DYNAGEN, INOGEN, ORIGEN, INCEPTA, ENERGEN, PUNCTUA, and COGNIS devices.

Pulse Width, also referred to as pulse duration, determines how long the output pulse will be applied between the pacing electrodes.

Consider the following when programming Pulse Width:

- Pulse Widths are independently programmable for each chamber.
- If a Pulse Width Threshold Test is performed, a minimum 3X pulse width safety margin is recommended.
- The energy delivered to the heart is directly proportional to the Pulse Width; doubling the Pulse Width doubles the energy delivered. Therefore, programming a shorter Pulse Width while maintaining an adequate safety margin may increase battery longevity. To prevent loss of capture, exercise caution when you are programming permanent Pulse Width values of less than 0.3 ms (Figure 4-6 Pulse waveform on page 4-14).

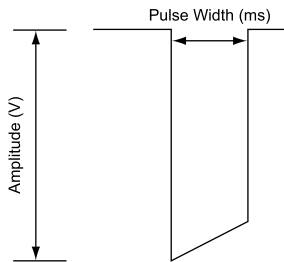

Figure 4-6. Pulse waveform

Amplitude

This feature is available in AUTOGEN, DYNAGEN, INOGEN, ORIGEN, INCEPTA, ENERGEN, PUNCTUA, and COGNIS devices.

The pulse amplitude, or voltage of the output pulse, is measured at the leading edge of the output pulse (Figure 4-6 Pulse waveform on page 4-14).

Consider the following when programming Amplitude:

- Amplitudes are independently programmable for each chamber.
- Brady Mode may be programmed to Off via permanent or temporary programming. In effect, this turns Amplitude Off to monitor the patient's underlying rhythm.
- The programmed Amplitude is recommended to be a minimum of 2X the capture threshold to provide adequate safety margin. Lower pace amplitudes will preserve/extend longevity. The programmed Amplitude should be a balance of adequate safety margin and effect upon battery longevity. If PaceSafe is programmed On, it will automatically provide an adequate safety margin and may help extend battery longevity.
- The energy delivered to the heart is directly proportional to the square of the amplitude: doubling the amplitude quadruples the energy delivered. Therefore, programming to a lower Amplitude while maintaining an adequate safety margin may increase battery longevity.

PaceSafe

PaceSafe Right Atrial Automatic Threshold (RAAT)

This feature is available in AUTOGEN devices.

PaceSafe RAAT is designed to dynamically adjust the atrial pacing output to ensure capture of the atrium by optimizing the output voltage to 2X the capture threshold to provide adequate safety margin (for thresholds less than or equal to 2.5 V). RAAT will measure pacing thresholds between 0.2 V and 4.0 V at 0.4 ms and the output will be a minimum of 2.0 V and a maximum of 5.0 V with a fixed pulse width of 0.4 ms.

NOTE: To function properly, RAAT requires a functional RV lead and a bipolar atrial lead.

NOTE: RAAT is only available in pulse generators programmed to DDD(R) and DDI(R) modes as well as DDI(R) Fallback Mode.

RAAT can be programmed on by selecting Auto from the Atrial Amplitude parameter options. Programming the atrial output to Auto will automatically adjust the Pulse Width to 0.4 ms and set the atrial voltage output to an initial value of 5.0 V unless there is a successful test result within the last 24 hours.

NOTE: Prior to programming RAAT on, consider performing a Commanded Atrial Automatic Threshold Measurement to verify that the feature functions as expected. RAAT testing is performed in a unipolar configuration and there may be a discrepancy between unipolar and bipolar thresholds. If the bipolar threshold is greater than the unipolar threshold by more than 0.5 V, consider programming a fixed Atrial Amplitude.

RAAT is designed to work with typical lead implant criteria and an atrial threshold between 0.2 V and 4.0 V at 0.4 ms.

The RAAT algorithm then measures the atrial pacing threshold each day and adjusts the voltage output. During testing, RAAT measures an evoked response signal to confirm that each atrial pacing output captures the atrium. If the device is unable to repeatedly measure an evoked response signal of sufficient amplitude, a “Low ER” or “Noise” message may be displayed and the algorithm will default to 5.0 V pacing amplitude. Consider programming a fixed atrial pacing amplitude in these situations and re-check with a Commanded RAAT test at a later follow-up; maturation of the lead-tissue interface may improve the performance of RAAT.

If testing is successful, the Atrial Amplitude is adjusted to 2X the highest measured threshold of the last 7 successful ambulatory tests (output Amplitude between 2.0 V and 5.0 V). Seven tests are used to account for circadian cycle effects on threshold and ensure an adequate safety margin. This also allows for a rapid increase in output due to a sudden rise in threshold while requiring consistently lower threshold measurements to decrease output (i.e., one low threshold measurement will not cause a decrease in output) (Figure 4–7 Effect of threshold change on RAAT pacing output on page 4-15).

NOTE: Since output is set to 2X the capture threshold to provide adequate safety margin and RV pacing occurs shortly after atrial pacing, there is no beat-to-beat capture verification or backup atrial pacing at any time.

When Daily Trend is selected along with a fixed Amplitude, automatic atrial threshold measurements will occur every 21 hours with no change to programmed output.

The RAAT feature is designed to operate with a large range of pacing leads (e.g., high impedance, low impedance, tined fixation, or positive fixation).

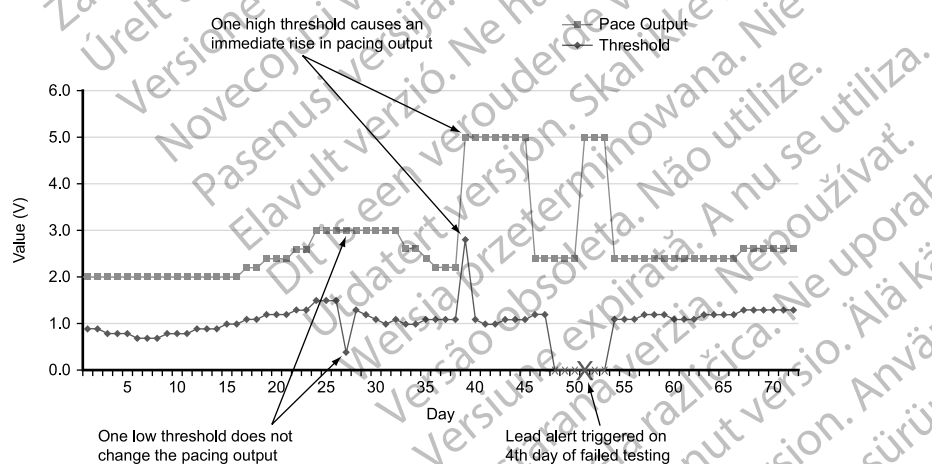

Figure 4–7. Effect of threshold change on RAAT pacing output

Ambulatory Atrial Automatic Threshold Measurement

Testing uses an RA tip >> can (unipolar) pacing vector and an RA ring >> can (unipolar) sensing vector even though the atrial lead is programmed to a normal brady Bipolar Pace/Sense configuration.

When RAAT is set to Auto or Daily Trend, ambulatory atrial automatic threshold measurements are conducted every 21 hours and the following parameters are adjusted to ensure a valid measurement is obtained:

- Starting atrial pacing amplitude is the output that RAAT is currently using. If that Amplitude value fails or if no previous results are available, the starting Amplitude is 4.0 V.
- The pacing amplitude will decrement in 0.5 V steps above 3.5 V and in 0.1 V steps at or below 3.5 V.
- Paced AV Delay is fixed at 85 ms.
- Sensed AV Delay is fixed at 55 ms.
- Initial pacing rate is set to the average atrial rate, the LRL or sensor-indicated rate, whichever is faster.
- If there are an insufficient number of atrial paces or if fusion occurs, the atrial pacing rate will be increased by 10 min⁻¹ (it may be increased a second time), but will not exceed the lowest of the MTR, MSR, MPR, 110 min⁻¹, or 5 min⁻¹ below the lowest VT Detection Rate.
- The Ventricular Pacing Chamber is not changed; however, if ventricular pacing is set to BiV and LV Offset is negative, the offset will be set to zero during testing.

Following initialization paces, the pulse generator will decrement the atrial output every 3 paces until a threshold is determined. If loss of capture occurs twice at a particular output level, threshold is declared as the previous output level that demonstrated consistent capture. If 3 captured beats occur at any particular output level, output decrements to the next level.

NOTE: *To ensure that loss of capture during RAAT does not encourage PMT (and also end the test prematurely due to too many atrial senses), the pulse generator uses a PMT algorithm. Following the loss of capture of any atrial beat, the PVARP following that ventricular event is extended to 500 ms to prevent tracking of a subsequent P-wave.*

If daily testing is unsuccessful, RAAT will return to the previously determined output and the pulse generator will perform up to 3 re-attempts at hourly intervals. If a successful test does not occur for 4 days, a Lead Alert will be triggered and RAAT will enter Suspension.

Right Atrial Automatic Threshold Suspension

If ambulatory testing fails in Auto mode for 4 consecutive days, RAAT will go into a Suspension mode and the pacing output will operate at 5.0 V and 0.4 ms. Testing will continue each day with up to 3 re-attempts to evaluate thresholds and the pulse generator will adjust to a lower output setting when indicated by a successful test.

Although RAAT is designed to work with a wide range of leads, in some patients the lead signals may hinder successful determination of the atrial threshold. In these instances, RAAT will continually operate in the Suspension mode at 5.0 V. In situations where Suspension mode persists for an extended period of time, it is recommended to turn RAAT off by programming a fixed atrial output.

Commanded Atrial Automatic Threshold Measurement

An automatic threshold measurement can be commanded via the Threshold Tests screen by selecting Auto Amplitude as the Test Type. If testing completes successfully and RAAT is programmed on, the output will automatically be set to 2X that test's measured threshold (between 2.0 V and 5.0 V). The last 7 successful daily measurements are cleared and the current commanded test result is used as the first successful test of a new 7 test cycle. This is to ensure that there will be an immediate output adjustment based on the current commanded test result

rather than on older ambulatory test data. This can be confirmed by observing the output voltage on the Brady Settings screen, which will show the actual operating voltage of the RAAT algorithm.

If testing is unsuccessful, the Threshold Tests screen will display a failure code indicating the reason the test was not successful, and the output will return to the previously set level (Table 4–1 Threshold Test Codes on page 4-17).

NOTE: For the initial Atrial Threshold test after the pulse generator is implanted, the Test Type field is seeded to Auto. Choose the desired test type from the Test Type field options, and adjust any other programmable values as appropriate.

NOTE: Commanded testing requires a functional bipolar atrial lead and may be performed in AAI mode.

Test Results and Lead Alerts

A stored EGM for the most recent successful ambulatory test will be stored in the Arrhythmia Logbook ("Arrhythmia Logbook" on page 6-2). Refer to the Daily Measurements screen for the resulting threshold value. If desired, the stored EGM can be reviewed to determine where loss of capture occurred.

Up to 12 months of Ambulatory Threshold Test results, as well as test failure codes and lead alerts, can be found within the Daily Measurement and Trends screens. To provide further information on the reason for test failure, a failure code is provided for each day in which testing fails. Additionally, failure codes are provided on the Threshold Test screen if a commanded automatic threshold test does not complete successfully. Threshold Test Failure Codes are listed below (Table 4–1 Threshold Test Codes on page 4-17).

The following scenarios will trigger the Check Atrial Lead alert:

- Threshold > Programmed Amplitude will be displayed if RAAT is in Daily Trend mode and the ambulatory test results of the last 4 consecutive days exceed the manually programmed fixed output.
- Automatic Threshold Suspension will be displayed if no successful tests are performed for 4 consecutive days in Auto or Daily Trend mode.

Table 4–1. Threshold Test Codes

Code	Reason
N/R: device telem.	Telemetry started during an ambulatory test
N/R: comm. lost	Telemetry was lost during a commanded test
N/R: no capture	Capture was not obtained at the starting amplitude for a commanded test or capture is > 4.0 V for an ambulatory test
N/R: mode switch	ATR mode switch either started or stopped
N/R: fusion events	Too many consecutive or too many total fusion events occurred
No data collected	Minimum pacing amplitude was reached without losing capture for an ambulatory test, or neither Auto nor Daily Trend is turned on to obtain an ambulatory result
N/R: battery low	Test was skipped due to Battery Capacity Depleted
N/R: noise	Too many consecutive sense channel noise or Evoked Response noise cycles occurred
N/R: incompat. mode	Incompatible Brady mode was present (e.g. VDI Fallback Mode)
N/R: rate too high	Rate was too high at the start of the test, a rate increase would raise the rate too high or more than 2 rate increases were required
N/R: user cancelled	Commanded test was stopped by the user

Table 4–1. Threshold Test Codes (continued)

Code	Reason
N/R: intrinsic beats	Too many cardiac cycles occurred during the test
N/R: test delayed	Test was delayed due to telemetry being active, VT episode already in progress, Electrocautery mode, MRI Protection Mode, or RAAT was turned on while the device remained in Storage mode
N/R: vent. episode	A Ventricular Episode started during testing
N/R: respiration	Respiratory artifact was too high
N/R: low ER	The Evoked Response signal could not be assessed adequately
Auto N/R	Minimum pacing amplitude was reached without losing capture for a commanded test, or telemetry is manually cancelled during a commanded test
N/R: recent shock	Ventricular shock therapy was delivered less than 60 minutes prior to the scheduled start of an ambulatory test

PaceSafe Right Ventricular Automatic Threshold (RVAT)

This feature is available in AUTOGEN devices.

PaceSafe RVAT is designed to dynamically adjust the right ventricular pacing output to ensure capture of the ventricle by optimizing the output voltage to 2X the capture threshold to provide adequate safety margin (for thresholds less than or equal to 2.5 V). RVAT will measure pacing thresholds between 0.2 V and 5.0 V at 0.4 ms, and the output will be a minimum of 2.0 V and a maximum of 5.0 V with a fixed Pulse Width of 0.4 ms.

NOTE: RVAT is available in DDD(R), DDI(R), VDD(R), and VVI(R) modes, as well as during VDI(R) and DDI(R) Fallback Modes.

RVAT can be programmed on by selecting Auto from the Ventricular Amplitude parameter options. If starting from a fixed amplitude greater than 5.0 V, program a fixed amplitude of 5.0 V prior to selecting Auto. Programming the ventricular output to Auto will automatically adjust the Pulse Width to 0.4 ms and set the ventricular voltage output to an initial value of 5.0 V unless there is a successful test result within the last 24 hours.

NOTE: Prior to programming RVAT on, consider performing a Commanded Ventricular Automatic Threshold Measurement to verify that the feature functions as expected.

RVAT is designed to work with typical lead implant criteria and measure a ventricular threshold between 0.2 V and 5.0 V at 0.4 ms.

The RVAT algorithm then measures the ventricular pacing threshold each day and adjusts the voltage output. During testing, RVAT uses an evoked response signal to confirm that each ventricular pacing output captures the ventricle.

The evoked response is sensed between the RV coil and can. This configuration provides a high electrode surface area which results in a small afterpotential, smaller pacing artifact, and improves sensing of the evoked response.

If testing is successful, the Ventricular Amplitude is adjusted to 2X the highest measured threshold of the last 7 successful ambulatory tests between 2.0 V and 5.0 V. Seven tests are used to account for circadian cycle effects on threshold and ensure an adequate safety margin. This also allows for a rapid increase in output due to a sudden rise in threshold while requiring consistently lower threshold measurements to decrease output (i.e. one low threshold measurement will not cause a decrease in output) (Figure 4–8 Effect of threshold changes on RVAT pacing output on page 4-19).

NOTE: Since output is set to 2X the capture threshold to provide adequate safety margin, there is no beat-to-beat capture verification.

When Daily Trend is selected along with a fixed Amplitude, automatic ventricular threshold measurements will occur every 21 hours with no change to programmed output.

The RVAT feature is designed to operate with a large range of pacing leads (e.g., high impedance, low impedance, integrated bipolar, dedicated bipolar).

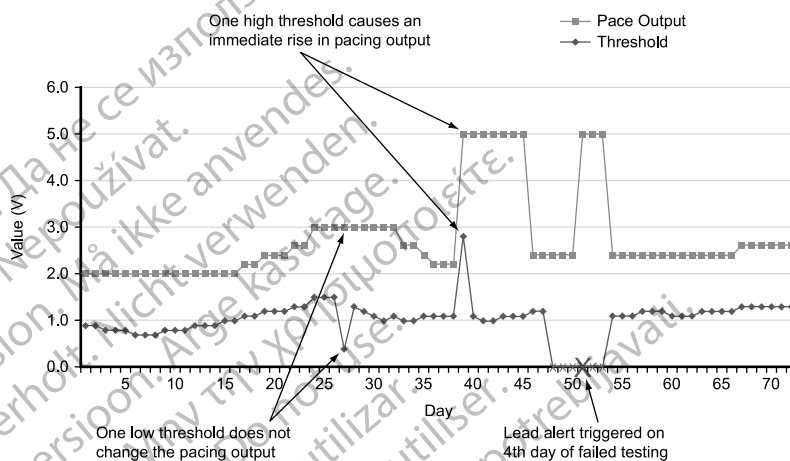

Figure 4-8. Effect of threshold changes on RVAT pacing output

Ambulatory Right Ventricular Automatic Threshold Measurement

When RVAT is set to Auto or Daily Trend, ambulatory ventricular automatic threshold measurements are conducted every 21 hours.

In atrial tracking modes, the automatic threshold measurement adjusts the following parameters to help ensure a valid measurement is obtained:

- Paced AV Delay is fixed at 60 ms.
- Sensed AV Delay is fixed at 30 ms.
- RV-Blank After A-Pace is fixed at 85 ms.
- LV pacing is temporarily suspended in order to evaluate an RV-only evoked response.
- Starting ventricular pacing output amplitude is the output which RVAT is currently using (or would be using when RVAT is set to Daily Trend only). If that amplitude fails or if no previous results are available, the starting amplitude is 5.0 V.
- The pacing amplitude will decrement in 0.5 V steps above 3.5 V and in 0.1 V steps at or below 3.5 V.
- A backup pulse is delivered approximately 90 ms after the primary pacing pulse when loss of capture is detected.

In nontracking modes, the automatic threshold measurement adjusts the following parameters to help ensure a valid measurement is obtained:

- Paced AV Delay is fixed at 60 ms.
- RV-Blank After A-Pace is fixed at 85 ms.

- LV pacing is temporarily suspended in order to evaluate an RV-only evoked response.
- Starting ventricular pacing output amplitude is the output which RVAT is currently using (or would be using when RVAT is set to Daily Trend only). If that amplitude fails or if no previous results are available, the starting amplitude is 5.0 V.
- The pacing amplitude will decrement in 0.5 V steps above 3.5 V and in 0.1 V steps at or below 3.5 V.
- A backup pulse is delivered approximately 90 ms after the primary pacing pulse when loss of capture is detected.
- The ventricular pacing rate will be increased by 10 min⁻¹ above the current rate (paced or intrinsic) and is capped at the lowest of the MPR, MSR, 110 min⁻¹, or 5 min⁻¹ below the lowest VT Detection Rate.

NOTE: If fusion (which could potentially be a noise beat) is detected, the amplitude of the next pace will be at 5.0 V if the testing voltage is above 1.0 V; otherwise, the amplitude of the next pace will be at 2.5 V.

Following initialization paces, the pulse generator will decrement the ventricular output every 3 paces until a threshold is determined. Additional pacing pulses will be issued if there is fusion or intermittent loss of capture. Threshold is declared as the previous output level that demonstrated consistent capture.

If daily testing is unsuccessful, RVAT will return to the previously determined output and the device will perform up to 3 re-attempts at hourly intervals. If a successful test does not occur for 4 days, a Lead Alert will be triggered and RVAT will enter Suspension.

Right Ventricular Automatic Threshold Suspension

If ambulatory testing fails in Auto mode for 4 consecutive days, RVAT will go into a Suspension mode and the pacing output will operate at 5.0 V and 0.4 ms. Testing will continue each day with up to 3 re-attempts to evaluate thresholds and the pulse generator will adjust to a lower output setting when indicated by a successful test.

Although RVAT is designed to work with a wide range of leads, in some patients the lead signals may hinder successful determination of the ventricular threshold. In these instances, RVAT will continually operate in the Suspension mode at 5.0 V. In situations where Suspension mode persists for an extended period of time, it is recommended to turn RVAT off by programming a fixed ventricular output.

Commanded Right Ventricular Automatic Threshold Measurement

An automatic threshold measurement can be commanded via the Threshold Tests screen by selecting Auto Amplitude as the Test Type. If testing completes successfully and RVAT is programmed on, the output will automatically be set to 2X that test's measured threshold (between 2.0 V and 5.0 V). The last 7 successful daily measurements are cleared and the current commanded test result is used as the first successful test of a new 7 test cycle. This is to ensure that there will be an immediate output adjustment based on the current commanded test result rather than on older ambulatory test data. This can be confirmed by observing the output voltage on the Brady Settings screen, which will show the actual operating voltage of the RVAT algorithm.

Backup pacing is delivered approximately 90 ms after the primary pace for every loss of capture beat during commanded testing.

If testing is unsuccessful, the Threshold Tests screen will display the reason the test was not successful, and the output will return to the previously set level (Table 4–2 Threshold Test Failure Codes on page 4-21).

NOTE: For the initial Ventricular Threshold Test after the pulse generator is implanted, the Test Type field is seeded to Auto. Choose the desired test type from the Test Type field options, and adjust any other programmable values as appropriate.

Test Results and Lead Alerts

A stored EGM for the most recent successful ambulatory test will be stored in the Arrhythmia Logbook ("Arrhythmia Logbook" on page 6-2). Refer to the Daily Measurements screen for the resulting threshold value. If desired, the stored EGM can be reviewed to determine where loss of capture occurred.

Up to 12 months of Ambulatory Threshold Test results, as well as test failure codes and lead alerts, can be found within the Daily Measurement and Trends screens. To provide further information on the reason for test failure, a failure code is provided for each day in which testing fails. Additionally, failure codes are provided on the Threshold Test screen if a commanded automatic threshold test does not complete successfully. Threshold Test Failure Codes are listed below (Table 4-2 Threshold Test Failure Codes on page 4-21).

The following scenarios will trigger the Check RV Lead alert:

- Threshold > Programmed Amplitude will be displayed if RVAT is in Daily Trend mode and the ambulatory test results of the last 4 consecutive days exceed the manually programmed fixed output.
- Automatic Threshold Suspension will be displayed if no successful tests are performed for 4 consecutive days in Auto or Daily Trend mode.

Table 4-2. Threshold Test Failure Codes

Code	Reason
N/R: device telem.	Telemetry started during an ambulatory test
N/R: comm. lost	Telemetry was lost during a commanded test
N/R: no capture	Capture was not obtained at the starting amplitude for a commanded test
N/R: mode switch	ATR either started or stopped (testing will not fail if ATR is already active and stays active during testing)
No data collected	Minimum pacing amplitude was reached without losing capture, neither Auto nor Daily Trend was turned on to obtain an ambulatory test result, loss of capture occurred at 5.0 V, or an inadequate number of initialization paces occurred
N/R: battery low	Test was skipped due to Battery Capacity Depleted
N/R: noise	Too many consecutive sense channel noise cycles occurred
N/R: rate too high	Rate was too high at the start of the test, or during testing
N/R: user cancelled	Commanded test was stopped by the user
N/R: intrinsic beats	Too many cardiac cycles occurred during the test or initialization restarted too many times
N/R: test delayed	Test was delayed due to telemetry being active, VT episode already in progress, Electrocautery mode, MRI Protection Mode, or RVAT was turned on while the device remained in Storage mode
N/R: vent. episode	A Ventricular Episode started during testing
Auto N/R	Minimum pacing amplitude was reached without losing capture for a commanded test or telemetry is manually cancelled during a commanded test
N/R: fusion events	Test failed due to too many consecutive fusion beats
N/R: recent shock	Ventricular shock therapy was delivered less than 60 minutes prior to the scheduled start of an ambulatory test

PaceSafe Left Ventricular Automatic Threshold (LVAT)

This feature is available in AUTOGEN devices.

PaceSafe LVAT is designed to dynamically adjust the left ventricular pacing output to ensure capture of the left ventricle using a programmable Safety Margin. LVAT will measure pacing thresholds from 0.2 V up to the programmable Maximum Amplitude (7.5 V maximum). The output will be at a minimum amplitude of 1.0 V up to the programmable Maximum Amplitude of 7.5 V (with a programmable pulse width).

NOTE: LVAT is available in DDD(R), DDI(R), VDD(R), and VVI(R) modes, as well as during VDI(R) and DDI(R) Fallback Modes.

LVAT is available in all LV pacing configurations and can be programmed on by selecting Auto from the Left Ventricular Amplitude parameter options. The Maximum Amplitude and Safety Margin can be programmed via the Pacing and Sensing Details button. The programmable Maximum Amplitude and Safety Margin are intended to allow the clinician to optimize the safety margin while also avoiding diaphragmatic stimulation. To determine an appropriate combination, it is recommended that testing be performed in multiple LV pacing configurations.

If starting from a fixed amplitude greater than the programmable maximum, program a lower amplitude prior to selecting Auto. Programming the left ventricular output to Auto will automatically set the left ventricular voltage output to the programmable Maximum Amplitude unless there is a successful test result within the last 24 hours.

NOTE: Prior to programming LVAT on, consider performing a Commanded Left Ventricular Automatic Threshold Measurement to verify that the feature functions as expected.

LVAT is designed to work with typical lead implant criteria and a left ventricular threshold between 0.2 V and the programmable Maximum Amplitude.

The LVAT algorithm then measures the left ventricular pacing threshold each day and adjusts the voltage output. During testing, LVAT uses an evoked response signal to confirm that each left ventricular pacing output captures the left ventricle. If the device is unable to repeatedly measure an evoked response signal of sufficient quality, an "Intrinsic Beats" or "Fusion Events" message may be displayed and the algorithm will default to the programmed Maximum Amplitude. Consider programming a fixed pacing amplitude in these situations and re-check with a Commanded LVAT test at a later follow-up; maturation of the lead-tissue interface may improve the performance of LVAT.

If testing is successful, the Left Ventricular Amplitude is adjusted by adding the programmable Safety Margin to the highest measured threshold of the last 7 successful ambulatory tests (between 1.0 V and the programmable Maximum Amplitude). Seven tests are used to account for circadian cycle effects on threshold and ensure an adequate safety margin. This also allows for a rapid increase in output due to a sudden rise in threshold while requiring consistently lower threshold measurements to decrease output (i.e. one low threshold measurement will not cause a decrease in output) (Figure 4–9 Effect of threshold changes on LVAT pacing output (with a programmable Maximum Amplitude of 5.0 V and Safety Margin of 1.0 V) on page 4-23).

NOTE: Since output is set with a programmable Safety Margin, there is no beat-to-beat capture verification.

When Daily Trend is selected along with a fixed Amplitude, automatic left ventricular threshold measurements will occur every 21 hours with no change to programmed output.

The LVAT feature is designed to operate with a large range of pacing leads (e.g., high impedance, low impedance).

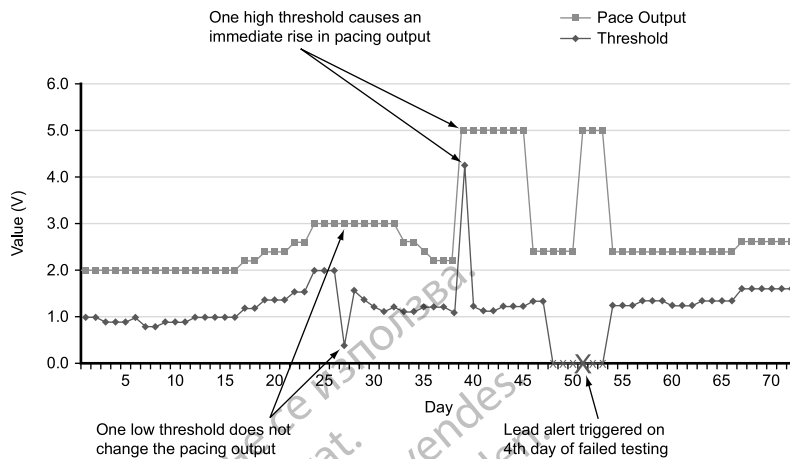

Figure 4-9. Effect of threshold changes on LVAT pacing output (with a programmable Maximum Amplitude of 5.0 V and Safety Margin of 1.0 V)

Ambulatory Left Ventricular Automatic Threshold Measurement

When LVAT is set to Auto or Daily Trend, ambulatory left ventricular automatic threshold measurements are conducted every 21 hours.

In atrial tracking modes, the automatic threshold measurement adjusts the following parameters to help ensure a valid measurement is obtained:

- Paced AV Delay is fixed at 140 ms.
- Sensed AV Delay is fixed at 110 ms.
- RV pacing is provided as backup throughout LV testing with an applied LV Offset of -80 ms.
- Starting left ventricular pacing output amplitude is the programmable Maximum Amplitude.
- The pacing amplitude will decrement in 0.5 V steps above 3.5 V and in 0.1 V steps at or below 3.5 V.

In nontracking modes, the automatic threshold measurement adjusts the following parameters to help ensure a valid measurement is obtained:

- Paced AV Delay is fixed at 140 ms.
- RV pacing is provided as backup throughout LV testing with an applied LV Offset of -80 ms.
- Starting left ventricular pacing output amplitude is the programmable Maximum Amplitude.
- The pacing amplitude will decrement in 0.5 V steps above 3.5 V and in 0.1 V steps at or below 3.5 V.
- The ventricular pacing rate will be increased by 10 min^{-1} above the current rate (paced or intrinsic) and is capped at the lowest of the MPR, MSR, 110 min^{-1} , or 5 min^{-1} below the lowest VT Detection Rate.

Following initialization paces, the pulse generator will decrement the left ventricular output every 3 paces until a threshold is determined. Additional pacing pulses will be issued if there is fusion or intermittent loss of capture. Threshold is declared as the previous output level that demonstrated consistent capture.

If daily testing is unsuccessful, LVAT will return to the previously determined output and the device will perform up to 3 re-attempts at hourly intervals. If a successful test does not occur for 4 days, a Lead Alert will be triggered and LVAT will enter Suspension.

Left Ventricular Automatic Threshold Suspension

If ambulatory testing fails in Auto mode for 4 consecutive days, LVAT will go into a Suspension mode and the pacing output will operate at the programmable pulse width and Maximum Amplitude. Testing will continue each day with up to 3 re-attempts to evaluate thresholds and the pulse generator will adjust to a lower output setting when indicated by a successful test.

Although LVAT is designed to work with a wide range of leads, in some patients the lead signals may hinder successful determination of the left ventricular threshold. In these instances, LVAT will continually operate in the Suspension mode at the programmable Maximum Amplitude. In situations where Suspension mode persists for an extended period of time, it is recommended to turn LVAT off by programming a fixed left ventricular output.

Commanded Left Ventricular Automatic Threshold Measurement

An automatic threshold measurement can be commanded via the Threshold Tests screen by selecting Auto Amplitude as the Test Type. If testing completes successfully in the currently programmed pacing lead configuration and LVAT is programmed on, the output will automatically be set by adding the programmable Safety Margin to that test's measured threshold (between 1.0 V and the programmable Maximum Amplitude). The last 7 successful daily measurements are cleared and the current commanded test result is used as the first successful test of a new 7 test cycle (if the test is performed in the currently programmed pacing lead configuration). This is to ensure that there will be an immediate output adjustment based on the current commanded test result rather than on older ambulatory test data. This can be confirmed by observing the output voltage on the Brady Settings screen, which will show the actual operating voltage of the LVAT algorithm.

RV pacing is provided as backup throughout LV testing with an applied LV Offset of -80 ms.

If testing is unsuccessful, the Threshold Tests screen will display the reason the test was not successful, and the output will return to the previously set level (Table 4–3 Threshold Test Failure Codes on page 4-25).

NOTE: When accessed from the Lead Tests screen, the initial Left Ventricular Threshold Test Type field is seeded to Auto after implant. Choose the desired test type from the Test Type field options, and adjust any other programmable values as appropriate.

Test Results and Lead Alerts

A stored EGM for the most recent successful ambulatory test will be stored in the Arrhythmia Logbook ("Arrhythmia Logbook" on page 6-2). Refer to the Daily Measurements screen for the resulting threshold value. If desired, the stored EGM can be reviewed to determine where loss of capture occurred.

Up to 12 months of Ambulatory Threshold Test results, as well as test failure codes and lead alerts, can be found within the Daily Measurement and Trends screens. To provide further information on the reason for test failure, a failure code is provided for each day in which testing fails. Additionally, failure codes are provided on the Threshold Test screen if a commanded automatic threshold test does not complete successfully. Threshold Test Failure Codes are listed below (Table 4–3 Threshold Test Failure Codes on page 4-25).

The following scenarios will trigger the Check LV Lead alert:

- Threshold > Programmed Amplitude will be displayed if LVAT is in Daily Trend mode and the ambulatory test results of the last 4 consecutive days exceed the manually programmed fixed output.
- Automatic Threshold Suspension will be displayed if no successful tests are performed for 4 consecutive days in Auto or Daily Trend mode.

Table 4–3. Threshold Test Failure Codes

Code	Reason
N/R: device telem.	Telemetry started during an ambulatory test
N/R: comm. lost	Telemetry was lost during a commanded test
N/R: no capture	Capture was not obtained at the starting amplitude
N/R: mode switch	ATR either started or stopped (testing will not fail if ATR is already active and stays active during testing)
No data collected	Minimum pacing amplitude was reached without losing capture, neither Auto nor Daily Trend is turned on to obtain an ambulatory test result, or an inadequate number of initialization paces occurred
N/R: battery low	Test was skipped due to Battery Capacity Depleted
N/R: noise	Too many consecutive sense channel noise cycles occurred
N/R: rate too high	Rate was too high at the start of the test, or during testing
N/R: user cancelled	Commanded test was stopped by the user
N/R: intrinsic beats	Too many cardiac cycles occurred during the test or initialization restarted too many times
N/R: test delayed	Test was delayed due to telemetry being active, VT episode already in progress, Electrocautery mode, MRI Protection Mode, or LVAT was turned on while the device remained in Storage mode
N/R: vent. episode	A Ventricular Episode started during testing
Auto N/R	Minimum pacing amplitude was reached without losing capture for a commanded test or telemetry is manually cancelled during a commanded test
N/R: fusion events	Test failed due to too many consecutive fusion beats
N/R: recent shock	Ventricular shock therapy was delivered less than 60 minutes prior to the scheduled start of an ambulatory test

Sensitivity

This feature is available in AUTOGEN, DYNAGEN, INOGEN, ORIGEN, INCEPTA, ENERGEN, PUNCTUA, and COGNIS devices.

The Sensitivity feature allows the pulse generator to detect intrinsic cardiac signals that exceed the programmed sensitivity value. Adjusting the Sensitivity value allows you to shift the atrial and/or ventricular sensing range to higher or lower sensitivity. All detection and timing decisions are based on the sensed cardiac signals. Atrial and ventricular Sensitivity values are independently programmable.

- High Sensitivity (low programmed value)—when Sensitivity is programmed to a very sensitive setting, the pulse generator may detect signals unrelated to cardiac depolarization (oversensing, such as sensing of myopotentials)
- Low Sensitivity (high programmed value)—when Sensitivity is programmed to a less sensitive setting, the pulse generator may not detect the cardiac depolarization signal (undersensing)

It is recommended that the Sensitivity parameter settings be left at the nominal values unless troubleshooting determines that another value may be more appropriate. While the nominal value is primarily indicated for both atrial and ventricular sensing, an adjustment can be made if, in a rare situation, atrial or ventricular oversensing/undersensing has been observed (e.g., inhibition of bradycardia pacing or inappropriate therapy)

WARNING: Left ventricular lead dislodgement to a position near the atria can result in atrial oversensing and left ventricular pacing inhibition.

Should it become necessary to adjust the Sensitivity parameter in a chamber, always choose the setting that provides appropriate sensing of intrinsic activity and best resolves oversensing/undersensing.

If proper sensing cannot be restored with an adjustment or if any undersensing or oversensing is observed after making a change, consider any of the following (taking into account individual patient characteristics):

- Reprogram the AGC sensitivity value
- Reprogram the Refractory or cross-chamber blanking period appropriately to address the observed undersensing or oversensing
- Reposition the lead
- Implant a new sensing lead

After any change to Sensitivity, evaluate the pulse generator for appropriate sensing and pacing.

CAUTION: Following any sensing range adjustment or any modification of the sensing lead, always verify appropriate sensing. Programming Sensitivity to the highest value (lowest sensitivity) may result in delayed detection or undersensing of cardiac activity. Likewise, programming to the lowest value (highest sensitivity) may result in oversensing of non-cardiac signals.

Automatic Gain Control

The pulse generator uses digital Automatic Gain Control (AGC) to dynamically adjust the sensitivity in both the atrium and the ventricle. The pulse generator has independent AGC circuits for each chamber.

Cardiac signals can vary widely in size and rate; therefore the pulse generator needs the ability to:

- Sense an intrinsic beat, regardless of rate or size
- Adjust to sense varying amplitude signals, but not overreact to aberrant beats
- Sense any intrinsic activity after a paced beat
- Ignore T-waves
- Ignore noise

The programmable AGC value is the minimum sensitivity value (floor) that could be reached between one beat and the next beat. This programmable value is not a fixed value present throughout the cardiac cycle; rather, the sensitivity level begins at a higher value (based on the peak of a sensed event or a fixed value for a paced event) and decrements towards the programmed floor (Figure 4–10 AGC sensing on page 4-28).

AGC will typically reach the programmable floor during pacing (or with low amplitude signals). But when moderate or high amplitude signals are sensed, AGC will typically be less sensitive and not reach the programmable floor.

The AGC circuit in each respective chamber processes an electrogram signal via a two step process to optimize sensing of potentially rapidly changing cardiac signals. The process is illustrated in the figure below (Figure 4–10 AGC sensing on page 4-28):

- First step

1. AGC uses a rolling average of previous signal peaks to calculate a search area where the next peak will likely occur.

- If the previous beat is sensed, it is incorporated into the rolling peak average.
- If the previous beat is paced, the peak average is calculated using the rolling average and a paced peak value. The paced peak value depends on the settings:
 - For nominal or more sensitive settings, it is a fixed value (initial value 4.8 mV in the RV, 8 mV in the LV, 2.4 mV in the RA).
 - For less sensitive settings, it is a higher value calculated using the programmed AGC floor value (for example, if RV sensitivity is programmed to the least sensitive setting or the highest value of 1.5 mV, the paced peak value = 12 mV).

The peak average is then used to bound an area with MAX (maximum) and MIN (minimum) limits.

- Second step

2. AGC senses the peak of the intrinsic beat (or uses the calculated peak for a paced beat as described above)
3. It holds the sensitivity level at the peak (or MAX) through the absolute refractory period + 15 ms.
4. It drops to 75% of the sensed peak or calculated peak average for paced events (ventricular paced events only).
5. AGC becomes more sensitive by 7/8 of the previous step.
6. Sensed beat steps are 35 ms for the RV and LV and 25 ms for the atrium. Paced beat steps are adjusted based on the pacing interval to ensure an approximately 50 ms sensing window at the MIN level.
7. It reaches the MIN (or programmed AGC Floor).
 - The programmed AGC Floor will not be reached if the MIN value is higher.
8. The AGC remains at the MIN (or programmed AGC floor) until a new beat is sensed, or the pacing interval times out and a pace is delivered.

NOTE: If a new beat is sensed as the sensitivity level steps down, AGC starts over at Step 1.

NOTE: If the amplitude of a signal is below the sensitivity threshold in effect at the time the signal occurs, it will not be sensed.

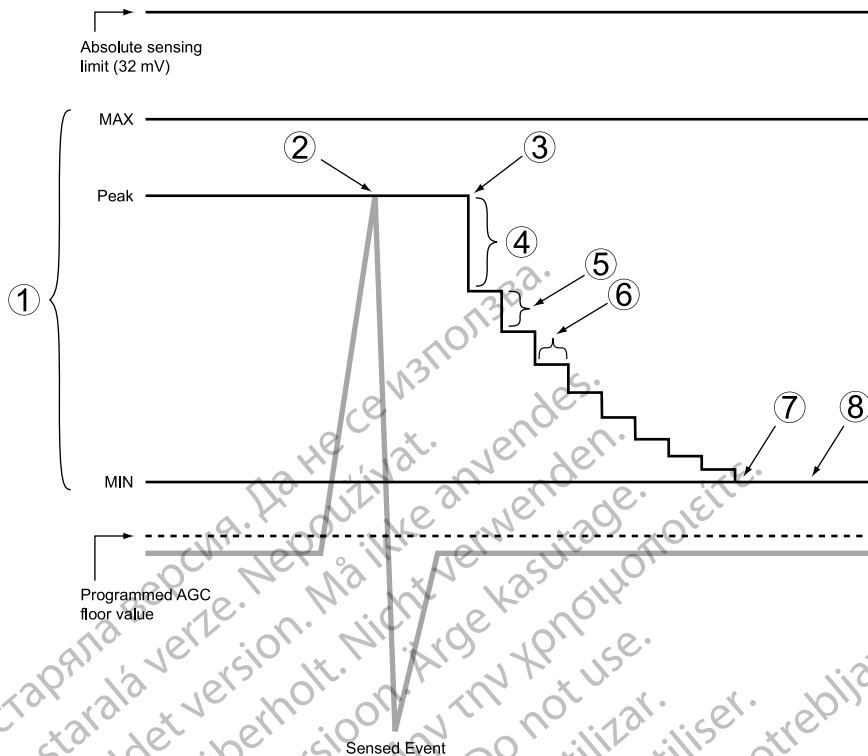

Figure 4-10. AGC sensing

A nonprogrammable Dynamic Noise Algorithm is active in rate channels where AGC sensing is used. The Dynamic Noise Algorithm is intended to help filter out persistent noise. The Dynamic Noise Algorithm is a separate noise channel for each chamber that continuously measures the baseline signal that is present and is designed to adjust the sensitivity floor to minimize the effects of noise.

The algorithm uses the characteristics of a signal (frequency and energy) to classify it as noise. When persistent noise is present, the algorithm is designed to minimize its impact, which may help to prevent oversensing myopotentials and the associated inhibition of pacing. Noise that affects the sensing floor may be visible on the intracardiac EGMs, but would not be marked as sensed beats. However, if the noise is significant, the floor may rise to a level above the intrinsic electrogram and the programmed Noise Response behavior (asynchronous pacing or Inhibit Pacing) will occur ("Noise Response" on page 4-75).

NOTE: The Dynamic Noise Algorithm does not ensure that AGC will always accurately distinguish intrinsic activity from noise.

POST-THERAPY PACING

This feature is available in AUTOGEN, DYNAGEN, INOGEN, ORIGEN, INCEPTA, ENERGEN, PUNCTUA, and COGNIS devices.

Post-therapy pacing provides alternate pacing therapy following the delivery of any shock.

The pacing mode and pacing therapies used following a shock are the same as the programmed Normal pacing settings.

The following pacing parameters can be programmed independently from the Normal pacing settings:

- Pacing Parameters—LRL, Amplitude, and Pulse Width
- Post Therapy Period

Post-Shock Pacing Delay

This feature is available in AUTOGEN, DYNAGEN, INOGEN, ORIGEN, INCEPTA, ENERGEN, PUNCTUA, and COGNIS devices.

The Post-Shock Pacing Delay determines the earliest possible start of post-shock pacing following the delivery of a ventricular shock and is fixed at 2.25 seconds.

NOTE: Depending on a COGNIS pulse generator's date of manufacture, the Post-Shock Pacing Delay may be fixed at 3 seconds.

The timing of the initial pacing pulse in the Post Therapy Period depends on the cardiac activity during the Post-Shock Pacing Delay.

- If R-waves (and/or P-waves for dual-chamber pacing modes) are sensed during the Post-Shock Pacing Delay, the device paces only when the sensed rate is slower than the post-therapy LRL.
- If no R-waves (and/or P-waves for dual-chamber pacing modes) are sensed during the Post-Shock Pacing Delay or if the interval since the preceding P- or R-wave was greater than the escape interval, a pacing pulse is delivered at the end of the Post-Shock Pacing Delay.

Subsequent pacing pulses are delivered as required, depending on the pacing prescription.

Post-Therapy Period

This feature is available in AUTOGEN, DYNAGEN, INOGEN, ORIGEN, INCEPTA, ENERGEN, PUNCTUA, and COGNIS devices.

The Post Therapy Period determines how long the pulse generator operates using the post-therapy parameter values.

The Post Therapy Period functions as follows:

- The period starts when the Post-Shock Pacing Delay expires
- On completion of this pacing period, the pulse generator reverts to the programmed Normal pacing values
- While in process, the pacing period is not affected by the end of the current episode

TEMPORARY BRADY PACING

This feature is available in AUTOGEN, DYNAGEN, INOGEN, ORIGEN, INCEPTA, ENERGEN, PUNCTUA, and COGNIS devices.

The pulse generator can be programmed with temporary pacing parameter values that differ from the programmed Normal Settings. This allows you to examine alternate pacing therapies while maintaining the previously programmed Normal Settings in the pulse generator memory. During the Temporary function, all other bradycardia features not listed on the screen are disabled.

NOTE: Post-therapy values are not affected.

To use this function, follow these steps:

1. From the Tests tab, select the Temp Brady tab to display the temporary parameters.

NOTE: Post-therapy values are not shown even if post-therapy is presently in effect.

2. Select the desired values; these values are independent from other pacing functions.

NOTE: *Temporary Brady interactive limits must be corrected before Temporary pacing can occur.*

NOTE: *If Off is selected as the Temporary Brady Mode, the pulse generator will not sense or pace while Temporary pacing mode is in effect.*

3. Establish telemetry communication, then select the Start button. Pacing begins at the temporary values. A dialog box indicates that temporary parameters are being used, and a Stop button is provided.

NOTE: *Temporary pacing cannot be started while a tachyarrhythmia episode is in progress.*

NOTE: *Emergency therapy is the only function that can be initiated until the Temporary function is stopped.*

4. To stop the Temporary pacing mode, select the Stop button. The Temporary pacing mode also stops when you command emergency therapy from the PRM, when you select DIVERT THERAPY, or if telemetry is lost.

Once Temporary pacing mode is stopped, pacing reverts to the previously programmed Normal/Post-Therapy settings.

RATE ADAPTIVE PACING AND SENSOR TRENDING

Rate Adaptive Pacing

In rate adaptive pacing modes (i.e., any mode ending with R), sensors are used to detect changes in the patient's activity level and/or physiologic demand and increase the pacing rate accordingly. Rate adaptive pacing is intended for patients who exhibit chronotropic incompetence and who would benefit from increased pacing rates that are concurrent with increased activity level and/or physiologic need.

The device can be programmed to use the Accelerometer, Minute Ventilation, or a blend of both. The clinical benefit of rate adaptive pacing using either of these sensors has been shown in previous clinical studies.

CAUTION: Rate Adaptive Pacing should be used with care in patients who are unable to tolerate increased pacing rates.

When rate adaptive parameters are programmed, the pacing rate increases in response to increased activity level and/or physiologic need, then decreases as appropriate.

NOTE: *Activity involving minimal upper body motion, such as bicycling, may result in only a moderate pacing response from the accelerometer.*

NOTE: *Rate Adaptive Pacing has been shown to be potentially proarrhythmic. Use caution when programming adaptive-rate features.*

CAUTION: The clinical benefit of Rate Adaptive Pacing in heart failure patients has not been studied. Rate Adaptive Pacing should be used with medical discretion if the patient develops an indication such as chronotropic incompetence. Patients with heart failure may have hemodynamic compromise at rapid sensor-driven rates, and the physician may wish to program less aggressive rate adaptive parameters in accordance with patient condition. Rate Adaptive Pacing may be helpful for heart failure patients with coexisting bradyarrhythmic conditions. It is not recommended for patients who exhibit only heart failure-induced chronotropic incompetency.

Accelerometer

This feature is available in AUTOGEN, DYNAGEN, INOGEN, ORIGEN, INCEPTA, ENERGEN, PUNCTUA, and COGNIS devices.

The accelerometer detects motion that is associated with a patient's physical activity and generates an electronic signal that is proportional to the amount of body motion. Based on accelerometer input, the pulse generator estimates the patient's energy expenditure as a result of exercise, then translates it into a rate increase.

The pulse generator senses body motion by means of an integrated circuit accelerometer. The accelerometer sensor responds to activity in the frequency range of typical physiologic activity (1–10 Hz). The accelerometer evaluates both the frequency and the amplitude of the sensor signal.

- Frequency reflects how often an activity occurs (e.g., the number of steps taken per minute during a brisk walk)
- Amplitude reflects the force of motion (e.g., the more deliberate steps taken while walking)

Once detected, an algorithm translates the measured acceleration into a rate increase above the LRL.

Because the accelerometer is not in contact with the pulse generator case, it does not respond to simple static pressure on the device case.

There are three Accelerometer settings: Off, On, and ATR Only. When you program the respective rate-responsive modes for Normal Settings and ATR Fallback, that action automatically updates the Accelerometer setting. If the pulse generator is permanently programmed to a non-rate adaptive mode, it is possible to program the ATR Fallback mode to an adaptive-rate mode using the accelerometer sensor. In this case, the Accelerometer field will display ATR Only.

The following programmable parameters control the pulse generator's response to the sensor values generated by the Accelerometer:

- Response Factor
- Activity Threshold
- Reaction Time
- Recovery Time

Response Factor (Accelerometer)

Response Factor (accelerometer) determines the pacing rate increase that will occur above the LRL at various levels of patient activity (Figure 4–11 Response Factor and paced rate on page 4-32).

- High Response Factor—results in less activity required for the pacing rate to reach the MSR
- Low Response Factor—results in more activity required for the pacing rate to reach the MSR

NOTE: Programming Response Factor for Normal Settings also changes the corresponding selection for Post-Therapy Settings.

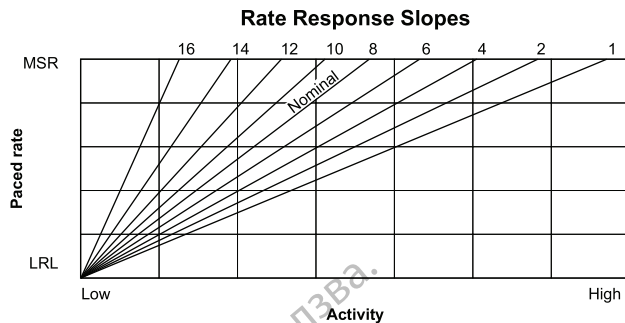
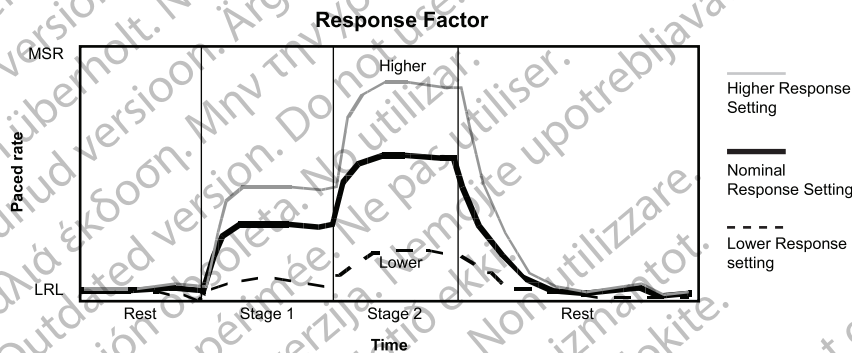

Figure 4-11. Response Factor and paced rate

The pacing rate achieved can be limited either by the detected activity level or the programmed MSR. If the detected activity level results in a steady-state rate below the MSR, the pacing rate can still increase when the detected activity levels increase (Figure 4-12 Response Factor in exercise test on page 4-32). The steady-state response is independent of the programmed reaction and recovery times.



This figure shows the effect of higher and lower settings during a theoretical two-stage exercise test.

Figure 4-12. Response Factor in exercise test

Programming the LRL up or down moves the entire response up or down without changing its shape.

Activity Threshold

Activity Threshold prevents rate increases due to low-intensity, extraneous motion (e.g., motion caused by respiration, heart beat, or in some cases tremor associated with Parkinson's disease).

Activity Threshold represents the activity level that must be exceeded before the sensor-driven pacing rate will increase. The pulse generator will not increase the paced rate above the LRL until the activity signal increases above the Activity Threshold. An Activity Threshold setting should allow a rate increase with minor activity, such as walking, but be high enough so the pacing rate will not increase inappropriately when the patient is inactive (Figure 4-13 Activity Threshold and rate response on page 4-33 and Figure 4-14 Activity Threshold in exercise test on page 4-33).

- Lower setting—less motion is required to increase the pacing rate
- Higher setting—more motion is required to increase the pacing rate

NOTE: Programming the Activity Threshold for Normal Settings also changes the corresponding selection for Post-Therapy Settings.

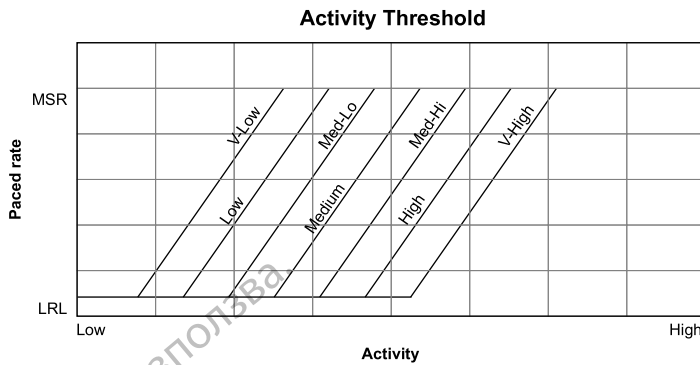
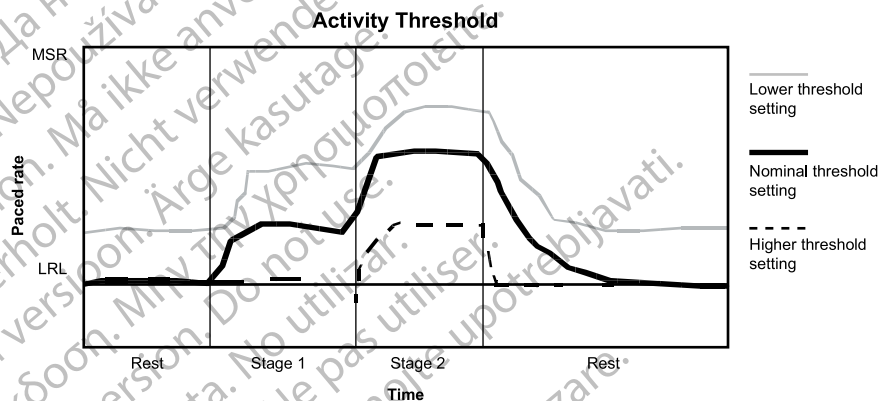

Figure 4-13. Activity Threshold and rate response



This figure demonstrates the effect of increased or decreased Activity Threshold settings in response to a theoretical two-stage exercise test.

Figure 4-14. Activity Threshold in exercise test

Reaction Time

Reaction Time determines how quickly the pacing rate will rise to a new level once an increase in activity level is detected.

Reaction Time affects only the time required for a rate increase to occur. The value selected determines the time required for the paced rate to move from the LRL to the MSR for a maximum level of activity (Figure 4-15 Reaction Time and paced rate on page 4-34 and Figure 4-16 Reaction Time in exercise test on page 4-34).

- Short Reaction Time: results in a rapid increase in the pacing rate
- Long Reaction Time: results in a slower increase in the pacing rate

NOTE: Programming Reaction Time for Normal Settings also changes the corresponding selection for Post-Therapy Settings.

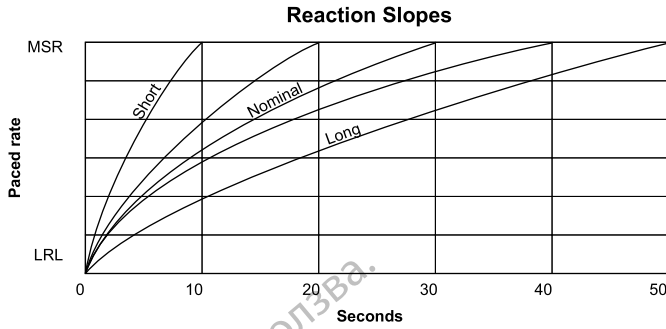

Figure 4-15. Reaction Time and paced rate

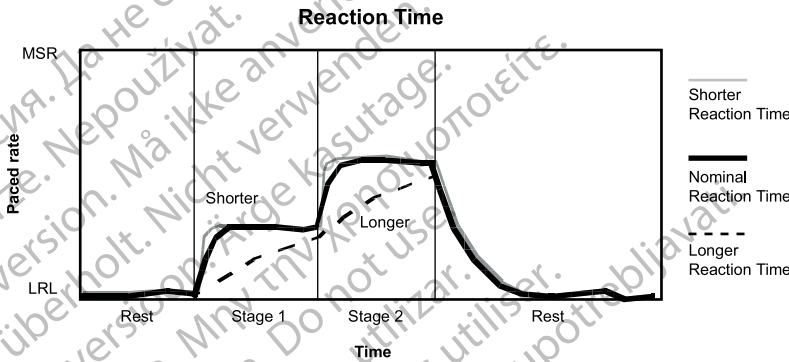

Figure 4-16. Reaction Time in exercise test

Recovery Time

Recovery Time determines the time required for the paced rate to decrease from the MSR to the LRL in the absence of activity. When patient activity concludes, Recovery Time is used to prevent an abrupt decrease in pacing rate (Figure 4-17 Recovery Time and paced rate on page 4-35 and Figure 4-18 Recovery Time in exercise test on page 4-35).

- Short Recovery Time—results in a faster decrease in pacing rate after patient activity lowers or stops
- Long Recovery Time—results in a slower decrease in pacing rate after patient activity lowers or stops

NOTE: Programming Recovery Time for Normal Settings also changes the corresponding selection for Post-Therapy Settings.

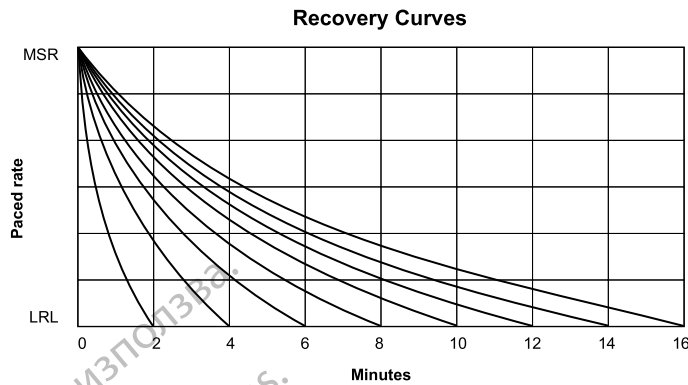

There are 15 settings available; only the even-numbered settings are shown.

Figure 4-17. Recovery Time and paced rate

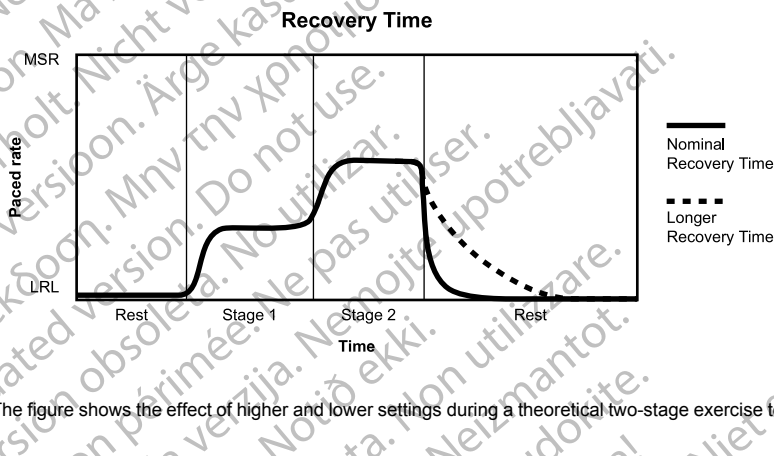

The figure shows the effect of higher and lower settings during a theoretical two-stage exercise test.

Figure 4-18. Recovery Time in exercise test

Minute Ventilation (MV)

This feature is available in AUTOGEN devices.

The pulse generator uses transthoracic impedance to measure minute ventilation (MV), which is the product of respiration rate and tidal volume. Based on the MV measurement, the pulse generator calculates the sensor-indicated rate.

CAUTION: Do not program the MV sensor to On until after the pulse generator has been implanted and system integrity has been tested and verified.

Approximately every 50 ms (20 Hz), the device will deliver a current excitation waveform between the RA Ring electrode and Can (primary vector) or the RV Coil and Can (secondary vector). Since either lead may be used to measure MV, at least one of the implanted leads must have normal bipolar lead impedances.

NOTE: Only the RV Coil to Can vector is available if an RA lead is not implanted.

Inductive (wanded) telemetry may temporarily interfere with the pulse generator's MV sensor function. MV driven rates may hold at the current rate for approximately one minute immediately following any interrogation or programming command. This period will be indicated by a Sensor Status of Rate Hold: Telemetry (Table 4-4 MV Sensor Status Messages on page 4-38). If a significant amount of data (for example, Arrhythmia Logbook episodes) is being retrieved from the device, the MV driven rate may then decrease to the LRL and further rate changes may not

occur for several additional minutes. This time period will be indicated by a Sensor Status of Suspended: Telemetry (Table 4–4 MV Sensor Status Messages on page 4-38).

If MV driven rate changes are desired prior to the rate hold or suspension periods, allow the MV driven rate to reach the desired rate prior to using inductive telemetry, or use RF telemetry to communicate with the device.

CAUTION: Any medical equipment, treatment, therapy, or diagnostic test that introduces electrical current into the patient has the potential to interfere with pulse generator function.

- External patient monitors (e.g., respiratory monitors, surface ECG monitors, hemodynamic monitors) may interfere with the pulse generator's impedance-based diagnostics (e.g., shock lead impedance measurements, Respiratory Rate trend). This interference may also result in accelerated pacing, possibly up to the maximum sensor-driven rate, when MV is programmed to On. To resolve suspected interactions with the MV sensor, deactivate the sensor either by programming it to Off (no MV rate driving or MV sensor-based trending will occur), or Passive (no MV rate driving will occur). Alternatively, program the Brady Mode to a non-rate responsive mode (no MV rate driving will occur).

To resolve suspected interactions with Respiratory Sensor-based diagnostics, deactivate the pulse generator's Respiratory Sensor by programming it to Off.

During MV function, the active vector may be the primary vector (RA Ring electrode to Can) or secondary vector (RV Coil to Can). Lead impedances for the active vector are evaluated each hour to assess lead integrity. If the active vector values are out of range, impedances for the alternate vector are evaluated to determine if that vector can be utilized for MV. If both the primary and secondary vectors are out of range, the sensor is suspended for the next one hour. Lead integrity will continue to be tested every hour to evaluate if the MV signal will use the primary vector, the secondary vector, or remain suspended. Acceptable lead impedance values are 200–2000 Ω for the tip to can vector, 100–1500 Ω for the ring to can vector, and 20–200 Ω for the coil to can vector.

If a vector switch occurs, an automatic 6-hour calibration will occur (no MV-driven rate response occurs during the 6-hour calibration period).

The application of current between the RA Ring electrode or RV Coil and the Can will create an electrical field across the thorax, modulated by respiration. During inspiration the transthoracic impedance is high, and during expiration it is low. The device will measure the resulting voltage modulations between the lead tip electrode and the can.

CAUTION: If MV/Respiratory Sensor signal artifacts are observed on EGMs, and the leads are otherwise shown to be performing appropriately, consider programming the sensor to Off to prevent oversensing.

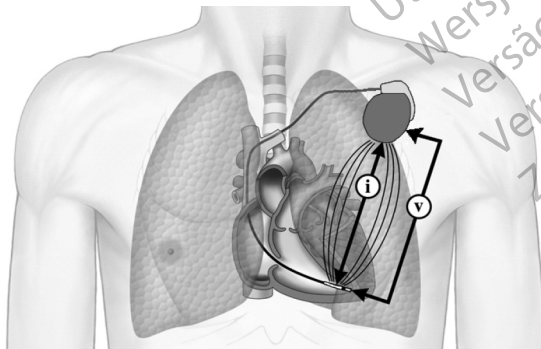

i = current, V = volts

Figure 4–19. Measurement of the MV signal from the RV lead

Due to advanced filtering, the algorithm supports breathing rates up to 72 breaths per minute. The filtered waveform is then processed to obtain the total volume measurement. The average excitation current that is delivered to the tissue is 320 μA . If the noise becomes excessive, the MV sensor will be suspended until the noise level decreases. The excitation waveform is a balanced low amplitude signal that will not distort surface ECG recordings. On some ECG monitoring equipment, the waveforms may be detected and displayed. These waveforms are present only when the MV sensor is used.

The pulse generator keeps a long-term moving average (baseline) of these measurements (updated every 4 minutes) as well as a short-term (approximately 30-second) moving average, which is updated every 7.5 seconds. The magnitude of the difference between the short-term average and long-term baseline determines the magnitude of the rate increase over the LRL, or decrease down to the LRL. The increase or decrease in the sensor-indicated rate occurs at a maximum of 2 min^{-1} per cycle (Figure 4–20 Difference between MV short-term average and MV baseline on page 4-37).

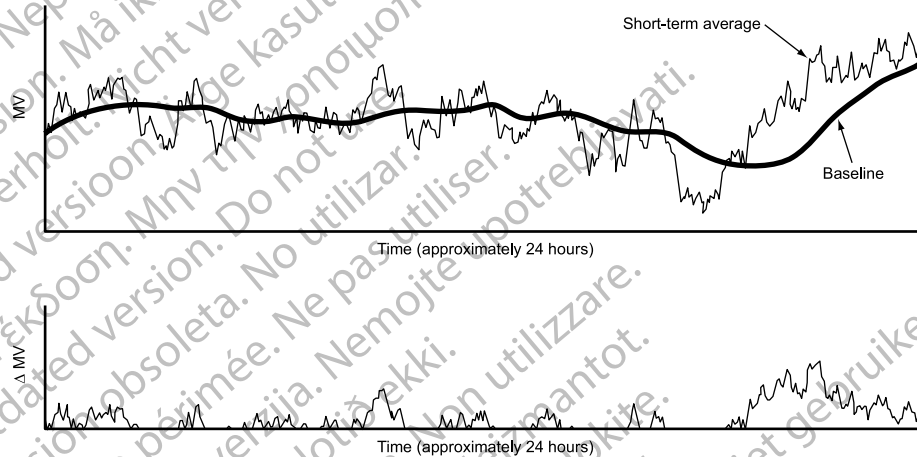

Top: The baseline (long-term average) follows the drift of the short-term average. Bottom: The difference between the short- and long-term average is used for increasing the sensor-driven rate upon exertion.

Figure 4–20. Difference between MV short-term average and MV baseline

CAUTION: Program the MV/Respiratory Sensor to Off during mechanical ventilation. Otherwise, the following may occur:

- Inappropriate MV sensor-driven rate
- Misleading respiration-based trending

For optimal rate response, a variety of Minute Ventilation parameters can be programmed via the RightRate Pacing area on the Rate Adaptive Pacing Settings screen.

To activate the MV sensor, the system needs a measure of the baseline or resting MV. Methods for calibration include:

- **Automatic Calibration.** An automatic, 6-hour calibration will occur whenever MV is programmed to On or Passive. No MV-driven rate response or hourly lead integrity checks will occur during the 6-hour calibration time. If MV is programmed to On at implant, the first hourly lead check with acceptable lead impedance values will begin a 2-hour wait period followed by the 6-hour calibration. This 2-hour period will be indicated by a sensor status of Initializing and is intended to allow the implantation procedure to be completed.

NOTE: If MV is programmed to On or Passive at the time of entry into MRI Protection Mode, upon exit from MRI Mode, an automatic 6-hour calibration will begin. If MV-driven rate response is desired sooner, a manual calibration can be performed.

- **Manual Calibration.** Whenever MV is programmed On, (including during the 2-hour period following lead attachment) the sensor can be calibrated manually. From the RightRate Pacing Details screen, select the Start Sensor Calibration button to initiate the manual calibration process. If the calibration is successful, MV-driven rate response takes effect within one minute. Manual calibration may take as little as 2 minutes or as much as 5 minutes to complete, depending on whether noise is encountered during data collection. The patient should be resting quietly and breathing normally for a few minutes prior to and during the manual calibration. If the manual calibration fails due to noise, it will be indicated by a Suspended: Noise Detected sensor status and the 6-hour automatic calibration will automatically begin. If the manual calibration fails due to no valid MV lead vector (indicated by a sensor status of Suspended: No Valid Lead), the pulse generator will continue to check for a valid vector every hour and will start the 6-hour calibration once a valid vector is detected.

NOTE: The Manual Calibration method will not be available upon initial interrogation while information such as Arrhythmia Logbook episodes are retrieved from the device. This will be indicated by a dimmed Start Sensor Calibration icon and may occur for seconds to minutes depending on the amount of data being retrieved.

There is no clinical difference between the Automatic and the Manual calibration methods. A successful Manual calibration simply allows a baseline to be obtained and MV-driven rate response to begin immediately. Neither calibration method requires that telemetry communication be maintained for the duration of the calibration.

CAUTION: To obtain an accurate MV baseline, the MV sensor will be calibrated automatically or can be calibrated manually. A new, manual calibration should be performed if the pulse generator is removed from the pocket following implant, such as during a lead repositioning procedure, or in cases where the MV baseline may have been affected by factors such as lead maturation, air entrapment in the pocket, pulse generator motion due to inadequate suturing, external defibrillation or cardioversion, or other patient complications (e.g., pneumothorax).

The PRM will display one of the messages below (all updated in real-time) to indicate the current MV Sensor Status on the RightRate Pacing Details screen (Figure 4–23 Ventilatory Threshold and Ventilatory Threshold Response on page 4-40). If a Ventricular Tachy episode is declared (8 out of 10 fast beats), the sensor will be suspended for the duration of the episode. Once the episode has ended, MV driven pacing will resume unless an automatic 6-hour calibration occurs due to a long episode or out of range lead impedances (test performed at end of episode).

Table 4–4. MV Sensor Status Messages

Sensor Status	MV Sensor Driven Pacing	MV Sensor Data Collection ^a
Off	No	No
Initializing	No	No
Manual Calibration in Progress	No	Yes
Auto Calibration in Progress	No	Yes
Calibrated	Yes ^b	Yes
Suspended	No	No
Suspended: No Valid Lead	No	No
Suspended: Noise Detected	No	Yes
Suspended: Telemetry	No	Yes

Table 4-4. MV Sensor Status Messages (continued)

Sensor Status	MV Sensor Driven Pacing	MV Sensor Data Collection ^a
Rate Hold: Telemetry	No ^c	Yes
Suspended: Tachy Episode	No	No

- a. Individual Trends determine if data collected during Suspension is valid and incorporated into Trend results.
- b. If the MV Sensor is programmed to Passive, MV sensor driven pacing will not occur.
- c. Rate will hold at the current MV indicated value for up to one minute; further MV based rate changes will not occur with this sensor status.

There are four Minute Ventilation settings: On, Off, Passive, and ATR Only. If the pulse generator is permanently programmed to a non-rate adaptive mode, but a rate adaptive ATR Fallback mode is selected, the MV field will display ATR Only. If programmed to a non-rate adaptive mode, the 'On' setting is not available. If Passive is selected, the MV sensor will not provide rate response but will continue to collect data for use by other features (e.g., Sensor Trending).

Response Factor (Minute Ventilation)

An increase in MV over baseline due to an increase in metabolic demand will be detected by the pulse generator and converted by its algorithm into an increased pacing rate. The relationship between the detected increase in MV and the resulting increase in the sensor-indicated rate is established by the MV Response Factor.

The Response Factor parameter determines the pacing rate that will occur above the LRL at various elevated levels of MV. Larger response factor values will result in higher sensor rates for a given MV level (Figure 4-21 Relationship between the programmed Response Factor setting and rate response on page 4-39). The effects of higher and lower Response Factor settings on sensor-driven pacing rate during a theoretical two-stage exercise test are illustrated below (Figure 4-22 Effects of Response Factor settings in a two-stage exercise test on page 4-39).

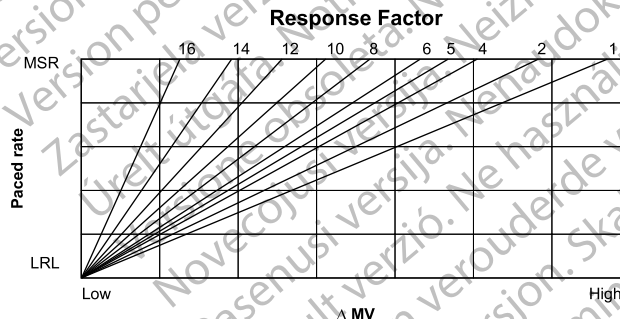

Figure 4-21. Relationship between the programmed Response Factor setting and rate response

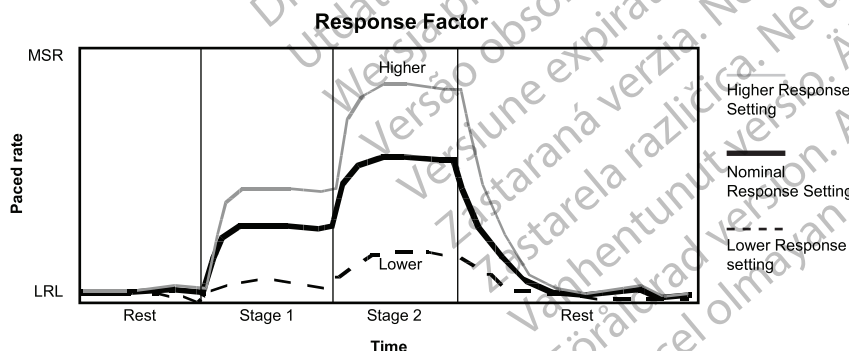

Figure 4-22. Effects of Response Factor settings in a two-stage exercise test

Ventilatory Threshold and Ventilatory Threshold Response

The Ventilatory Threshold and Ventilatory Threshold Response can be either manually programmed or automatically derived from patient information. The clinician can select Derive from Patient Attributes from the RightRate Pacing Details screen to obtain settings based on the patient's age and gender (and Fitness Level, see below). As parameters are changed, the graph will likewise adjust to demonstrate the effect of the new programming on overall rate response (Figure 4–23 Ventilatory Threshold and Ventilatory Threshold Response on page 4-40). If the Date of Birth or Gender is adjusted on the Patient Information screen, the new values will also be reflected on the RightRate Pacing Details screen.

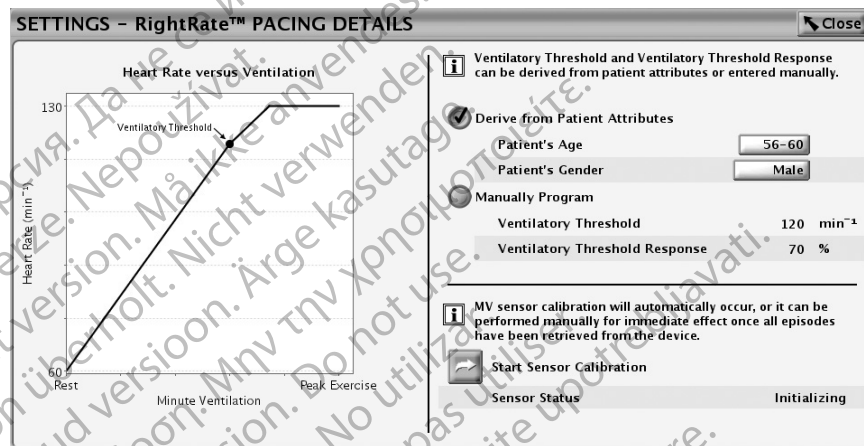

Figure 4–23. Ventilatory Threshold and Ventilatory Threshold Response

Ventilatory Threshold

Ventilatory Threshold is a physiologic term describing the point during exercise when the breathing rate increases faster than the heart rate (sometimes referred to as Anaerobic or Lactate Threshold).

The Response Factor controls the MV rate response for sensor rates between the LRL and the Ventilatory Threshold. The Ventilatory Threshold Response controls the MV rate response when the sensor rate is above the Ventilatory Threshold.

Ventilatory Threshold Response

The physiologic relationship between MV and rate is approximately bilinear as shown (Figure 4–24 Typical physiologic relationship between MV and heart rate on page 4-41). During exercise levels up to the Ventilatory Threshold, this relationship can be approximated by a linear relationship. At exertion levels above the Ventilatory Threshold, the relationship is still approximately linear, but at a reduced slope. The relationship between the two slopes varies from person to person and depends on several factors such as gender, age, and exercise frequency and intensity. The pulse generators allow programming of a slope above the Ventilatory Threshold that is less steep and thus designed to mimic the physiologic relationship between respiration rate and heart rate. The Ventilatory Threshold Response is programmed as a percentage of the Response Factor. Ventilatory Threshold Response is in effect at rates above the Ventilatory Threshold and will result in a less aggressive response to MV at higher rates (Figure 4–25 Ventilatory Threshold Response on page 4-41).

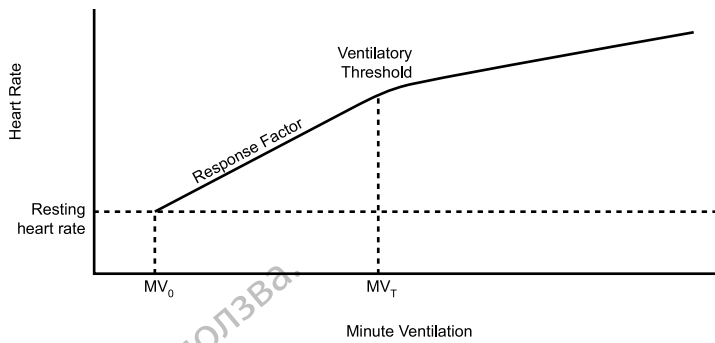

MV_0 = resting MV; MV_T = MV at the Ventilatory Threshold

Figure 4-24. Typical physiologic relationship between MV and heart rate

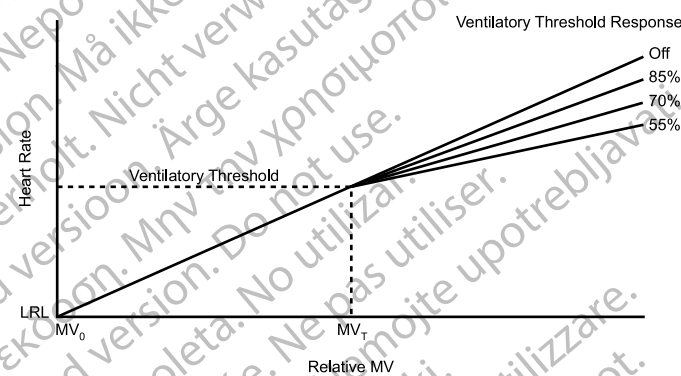

The Response Factor is linear from the resting state up to the Ventilatory Threshold (MV_0 = resting MV; MV_T = MV at the Ventilatory Threshold).

Figure 4-25. Ventilatory Threshold Response

Fitness Level

The selected Fitness Level will automatically determine an appropriate Ventilatory Threshold Response factor and rate at which the MV baseline will be fixed.

Table 4-5. Recommended Fitness Level settings

Recommended Fitness Level setting	Patient activity level
Sedentary	Little to no physical activity
Active	Regular walking and low impact activities
Athletic	Moderate intensity, non-competitive jogging/biking
Endurance Sports	Strenuous, competitive activities such as marathons

The baseline (long-term average) is fixed for up to 4.5 hours. This allows active patients who exercise for a long duration (e.g., long-distance runners) to maintain an adequate sensor-driven rate throughout the exercise period. The baseline will be fixed when the sensor indicated rate is above 110 min^{-1} for the Fitness Level setting of Endurance Sports or 90 min^{-1} for the other three Fitness Level settings. After 4.5 hours, or when the sensor rate falls below 90 min^{-1} or 110 min^{-1} as defined above, baseline adaptation will be re-enabled.

Dual-Sensor Blending

Whenever both the Accelerometer and the MV sensor are programmed On for rate adaptive pacing, the two sensor-indicated rates are blended to produce a rate-dependent, weighted average response. As a result, the blended response will always be equal to one of the rates or between the two rates. Whenever the Accelerometer response is less than the MV response, the sensor blending will be 100% MV-based. If the Accelerometer response is greater than the MV response, the blending will range from approximately 80% Accelerometer and 20% MV when the Accelerometer rate is at LRL, to approximately 40% Accelerometer and 60% MV when the Accelerometer rate is at MSR.

The following examples illustrate the blending algorithm operation.

Example 1

The Accelerometer detects motion with a simultaneous MV increase (Figure 4–26 Blended response with an Accelerometer Reaction Time of 30 seconds on page 4-42). Upon exercise, the blended response will promptly (within 4 seconds) increase the rate based on the Accelerometer response. As the rate continues to increase, the blended response will be moving toward the MV response, but will always remain between the Accelerometer and MV responses. At higher rates, the changes in Accelerometer input will have a lesser effect on the blended response (only 40% at MSR), whereas changes in MV will have a more significant effect. At cessation of exercise, the Accelerometer rate will decrease as prescribed by the Recovery Time parameter and, in this example, will drop below the MV response. As a result, the algorithm will switch over to a 100% MV blend during the recovery phase for as long as the Accelerometer response remains below the MV response. When using dual-sensor blending, retain the nominal Accelerometer value of 2 minutes. This allows the physiologic MV signal to control rate adaptive pacing in the exercise recovery phase.

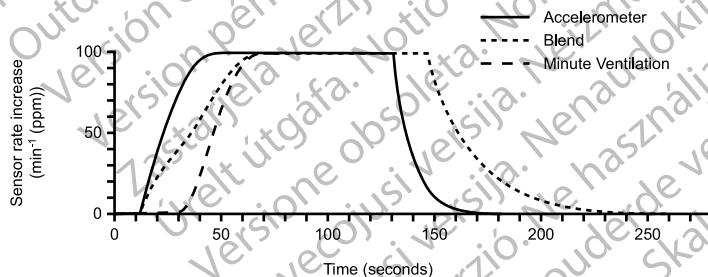

Figure 4–26. Blended response with an Accelerometer Reaction Time of 30 seconds

The aggressiveness of response at the onset of exercise can be controlled by programming a shorter Accelerometer Reaction Time (Figure 4–27 Blended response with an Accelerometer Reaction Time of 20 seconds on page 4-42).

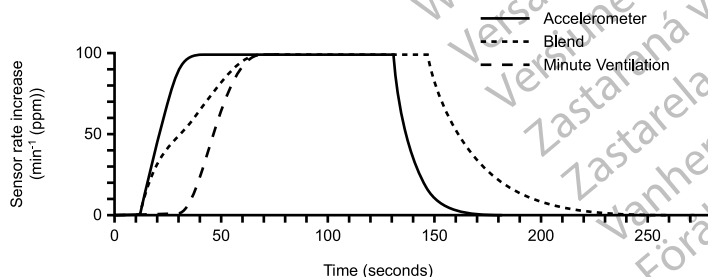

Figure 4–27. Blended response with an Accelerometer Reaction Time of 20 seconds

Example 2

The Accelerometer detects motion with little MV increase (Figure 4–28 Blended response: Accelerometer detects motion with little or no increase in MV on page 4-43). The response of the blended sensor will be limited to approximately 60% of the Accelerometer response. Once the Accelerometer response drops below the MV response during recovery, the blended response will be 100% MV-driven.

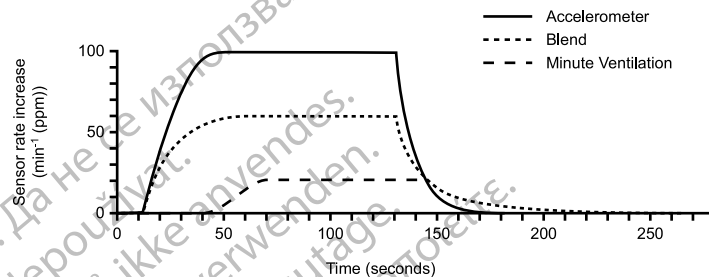

Figure 4–28. Blended response: Accelerometer detects motion with little or no increase in MV

Example 3

MV increases with little Accelerometer rate increase (Figure 4–29 Blended response: MV increase with little or no motion detected by the Accelerometer on page 4-43). The blended response will initially increase with the Accelerometer response, but as the MV response increases over the Accelerometer response, the blended response will be 100% MV-driven. This provides adequate response during increases in metabolic demand under conditions of little or no upper body movement.

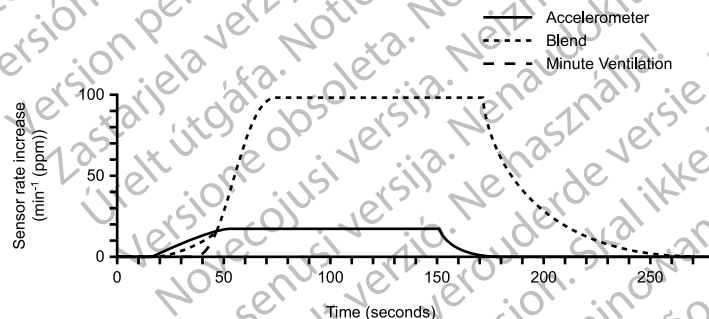

Figure 4–29. Blended response: MV increase with little or no motion detected by the Accelerometer

Sensor Trending

This feature is available in AUTOGEN, DYNAGEN, INOGEN, ORIGEN, INCEPTA, ENERGEN, PUNCTUA, and COGNIS devices.

Sensor Trending provides a graphical display of the pulse generator's rate response to the patient's detected activity level and/or physiologic need and provides useful information during exercise testing. This allows the clinician to adapt the sensor-driven pacing rate to correspond to the patient's actual need.

For AUTOGEN, DYNAGEN, INOGEN, and ORIGEN devices, the Sensor Trending graph and Sensor Trending Setup parameters are viewable via the Rate Adaptive Pacing screen (Figure 4–30 Sensor Trending graph on page 4-44).

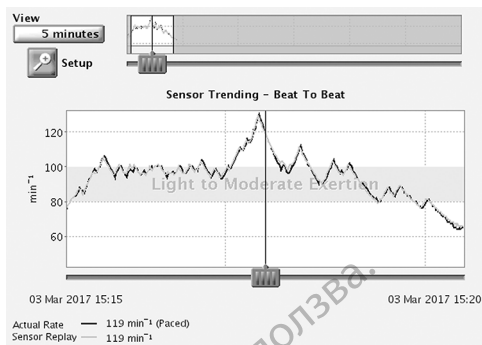

Figure 4-30. Sensor Trending graph

For INCEPTA, ENERGEN, PUNCTUA, and COGNIS devices, the Sensor Trending screen is accessible from within Normal Settings (Figure 4-31 Sensor Trending screen on page 4-44).

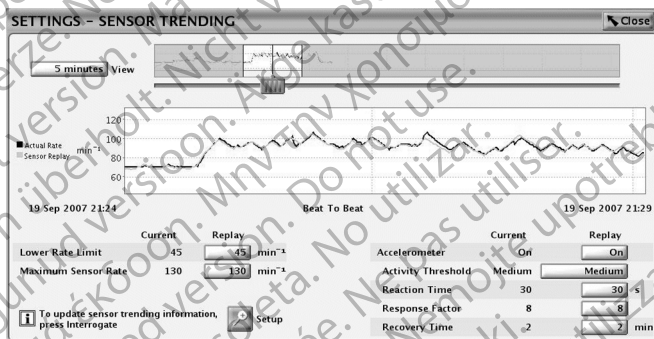

Figure 4-31. Sensor Trending screen

Setup includes the following options:

- Recording Method—programmable:
 - 30-Second Average—records and plots the average rate every 30 seconds.
 - Beat to Beat—records and plots the rate of every beat.

NOTE: *Beat to Beat is recommended when using hall walks or shorter periods of activity to manually optimize sensor rates.*

 - Off—no trending data is gathered.
- Duration—non-programmable and based on the selected Recording Method:
 - When Recording Method is set to Off or 30-Second Average—Duration is approximately 25 hours.
 - When Recording Method is set to Beat to Beat—Duration is approximately 40 minutes at 75 min⁻¹.
- Data Storage—programmable:
 - Continuous—contains the most recent data available. Storage starts when setup is confirmed and continuously records the latest information, overwriting the oldest data until the information is retrieved. This option allows you to view data for the recording duration immediately prior to data retrieval.
 - Fixed—storage starts when setup is confirmed and continues until device memory storage is full. This allows you to view data from initial setup for a fixed amount of time.

The pulse generator collects and stores rate and sensor data which is then displayed on the PRM in a graphical format as the patient's Actual Rate and Sensor Replay during the recording time.

The Actual Rate (black line) indicates the patient's heart rate during activity (whether paced or sensed). The Sensor Replay (orange line) depicts the sensor-driven heart rate response with the current sensor parameter settings.

For AUTOGEN, DYNAGEN, INOGEN, and ORIGEN devices, as the slider along the horizontal axis of the graph is moved, actual and sensor-indicated heart rates are displayed for particular data points. Additionally, the atrial events represented by a particular data point (single beat or 30-second average) are classified and displayed next to the Actual Rate. Events are classified and displayed as one or more of the following: Paced, Sensed, Sensed in ATR, VT. This event type will reflect ventricular events in VVI(R) modes.

Current sensor parameters (AUTOGEN, DYNAGEN, INOGEN, and ORIGEN devices) or the Sensor Replay parameters (INCEPTA, ENERGEN, PUNCTUA, and COGNIS devices) can be adjusted to view the resulting change to sensor rate behavior without having to repeat an exercise test.

The pulse generator can collect and store data in rate adaptive and non-rate adaptive modes:

- For AUTOGEN, DYNAGEN, INOGEN, and ORIGEN devices, in non-rate adaptive modes, the trending is collected via the Passive sensor setting. Passive allows for sensor data collection that can be used to optimize the sensors in the absence of the sensor-driven rate response. However, when the sensor setting is Passive, Sensor Replay data will not be displayed on the graph until a rate responsive mode is selected.
- For INCEPTA, ENERGEN, PUNCTUA, and COGNIS devices, to collect Accelerometer sensor trending data without a rate response, program the Brady Mode to a non-rate-adaptive mode and program the Recording Method for Sensor Trending to a value other than Off. However, without the sensor data comparison, only rate data will be displayed.

The pulse generator will record Sensor Trending data while wanded or RF telemetry is active.

When the heart rate is completely sensor-driven, small differences between the Actual Rate and Sensor Replay may still be observed because they are calculated independently by slightly different methods.

Working with Trending Data

To use the Sensor Trending function, follow these steps:

1. Following an exercise session, navigate to the Sensor Trending graph and press Interrogate to update trending information. Trending data is retrieved on initial interrogation. If a session remains active while the patient performs a hall walk, press Interrogate again to update the trending information.
2. Select the View button to expand or compress the amount of data viewed at one time. The start and end dates and times at the bottom of the graph will change to reflect the time period represented on the graph. The 30 Second Average Recording Method has options for 1 to 25 hours, and the Beat to Beat Recording Method has options for 5 to 40 minutes.
3. To adjust which data is displayed on the graph or to view particular data points, move the slider(s) along the horizontal axes at the bottom of the display windows.
4. Adjust the sensor parameters to the right of the graph (AUTOGEN, DYNAGEN, INOGEN, and ORIGEN devices) or under Sensor Replay (INCEPTA, ENERGEN, PUNCTUA and COGNIS devices) to see how adjustments in the rate adaptive pacing parameters will affect the sensor response (orange line). As these parameters and/or the MSR and LRL are

changed on the screen, the application will modify the graph to illustrate the resulting effects. If the patient's heart rate is appropriate for the activity performed, no sensor optimization is necessary.

- When a patient's heart rate is within the desired range for the activity performed, select Program (AUTOGEN, DYNAGEN, INOGEN, and ORIGEN devices) or reprogram values via the Accelerometer button (INCEPTA, ENERGEN, PUNCTUA and COGNIS devices).

NOTE: For AUTOGEN, DYNAGEN, INOGEN, and ORIGEN devices, Sensor Trending results may be printed via the Reports tab. Both the Present (currently programmed) and Replay (clinician adjusted) parameters are provided in addition to the current graph as represented on the programmer screen.

NOTE: Sensor adjustments should not be based on data which is collected during the MV calibration time period.

ATRIAL TACHY RESPONSE

ATR Mode Switch

This feature is available in AUTOGEN, DYNAGEN, INOGEN, ORIGEN, INCEPTA, ENERGEN, PUNCTUA, and COGNIS devices.

ATR is designed to limit the amount of time that the ventricular paced rate is at the MTR or exhibits upper-rate behavior (2:1 block or Wenckebach) in response to a pathological atrial arrhythmia.

ATR also limits the amount of time that CRT is inhibited due to pathological atrial tachycardia.

In the presence of detected atrial activity that exceeds the ATR Trigger Rate, the pulse generator switches the pacing mode from a tracking mode to a nontracking mode as follows:

- From DDD(R) to DDI(R) or VDI(R)
- From VDD(R) to VDI(R)

An example of ATR behavior is shown (Figure 4–32 ATR behavior on page 4-46).

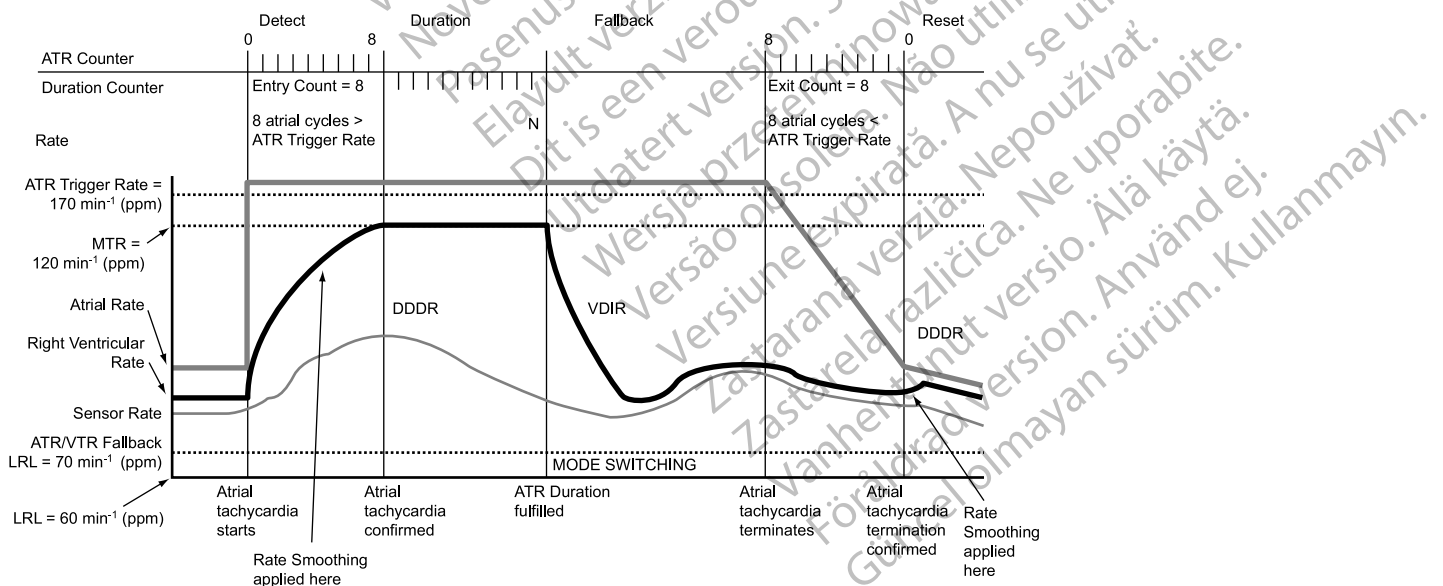

Figure 4–32. ATR behavior

CAUTION: ATR should be programmed to On if the patient has a history of atrial tachyarrhythmias. The delivery of CRT is compromised because AV synchrony is disrupted if the ATR mode switch occurs.

When a heart failure patient has an atrial tachyarrhythmia episode, the effectiveness of CRT is compromised because AV synchrony is disrupted. While ATR cannot resolve AV asynchrony, it can quickly bring the biventricular paced rate from the MTR to the ATR/VTR Fallback LRL, VRR rate or sensor-indicated rate (DDIR or VDIR). Programming a short ATR Duration and ATR Fallback Time allows a quicker mode switch and faster decrease in the biventricular pacing rate.

Patients with intact AV conduction may have conducted ventricular rates during ATR episodes. If the intrinsic ventricular rate exceeds the biventricular pacing rate during the ATR episode, biventricular pacing will be inhibited. For these patients, consider programming the VRR and BiV Trigger features to On.

NOTE: *In ATR, the pacing chamber is always biventricular, regardless of the permanently programmed Ventricular Pacing Chamber.*

NOTE: *Parameter settings that reduce the atrial sensing window may inhibit ATR therapy.*

ATR Trigger Rate

The ATR Trigger Rate determines the rate at which the pulse generator begins to detect atrial tachycardias.

The pulse generator monitors atrial events throughout the pacing cycle, except during the atrial blanking period and the noise rejection intervals. Atrial events faster than the Trigger Rate increase the ATR detection counter; atrial events slower than the Trigger Rate decrease the counter.

When the ATR detection counter reaches the programmed entry count, the ATR Duration begins. When the ATR detection counter counts down from the programmed Exit Count value to zero at any point in time, ATR Duration and/or fallback are terminated, and the ATR algorithm is reset. An event marker is generated whenever the ATR detection counter is incremented or decremented.

NOTE: *During post-therapy pacing, ATR functions the same as in normal pacing.*

ATR Duration

ATR Duration is a programmable value that determines the number of ventricular cycles during which the atrial events continue to be evaluated after initial detection (entry count) is met. This feature is intended to avoid mode switching due to short, nonsustained episodes of atrial tachycardia. If the ATR counter reaches zero during ATR Duration, the ATR algorithm will be reset, and no mode switch will occur.

If the atrial tachycardia persists for the programmed ATR Duration, then mode switching occurs and the Fallback Mode and Fallback Time begin.

Entry Count

The Entry Count determines how quickly an atrial arrhythmia is initially detected.

The lower the programmable value, the fewer the fast atrial events required to fulfill initial detection. Once the number of fast atrial events detected equals the programmable Entry Count, ATR Duration begins, and the Exit Count is enabled.

CAUTION: Exercise care when programming the Entry Count to low values in conjunction with a short ATR Duration. This combination allows mode switching with very few fast atrial beats. For example, if the Entry Count was programmed to 2 and the ATR Duration to 0, ATR mode

switching could occur on 2 fast atrial intervals. In these instances, a short series of premature atrial events could cause the device to mode switch.

Exit Count

The Exit Count determines how quickly the ATR algorithm is terminated once the atrial arrhythmia is no longer detected.

The lower the programmed value, the more quickly the pulse generator will return to an atrial tracking mode once an atrial arrhythmia terminates. Once the number of slow atrial events detected equals the programmable Exit Count, ATR Duration and/or Fallback will be terminated, and the ATR algorithm will be reset. The ATR Exit Count is decremented by atrial events slower than the ATR Trigger Rate or by any ventricular event that occurs more than two seconds after the last atrial event.

CAUTION: Exercise care when programming the Exit Count to low values. For example, if the Exit Count was programmed to 2, a few cycles of atrial undersensing could cause termination of mode switching.

Fallback Mode

Fallback Mode is the nontracking pacing mode that the pulse generator automatically switches to when ATR Duration is fulfilled.

After switching modes, the pulse generator gradually decreases the ventricular paced rate. This decrease is controlled by the Fallback Time parameter.

NOTE: *Dual-chamber pacing fallback mode values are only available when the Normal pacing mode is also set to dual-chamber.*

NOTE: *ATR Fallback mode may be programmed rate responsive even if the permanent brady mode is non-rate responsive. In this scenario, the sensor parameters will indicate "ATR Only".*

Fallback Time

Fallback Time controls how quickly the paced rate will decrease from the MTR to the ATR/VTR Fallback LRL during fallback. The paced rate will decrease to the highest of the sensor-indicated rate, VRR rate, or the ATR/VTR Fallback LRL.

During fallback, the following features are disabled:

- Rate Smoothing—disabled until fallback reaches the ATR/VTR Fallback LRL or the sensor-indicated rate. If VRR is enabled, then Rate Smoothing is disabled throughout the mode switch
- Rate Hysteresis
- PVARP Extension

Fallback LRL

The ATR/VTR Fallback LRL is the programmed lower rate to which the rate decreases during mode switching. The ATR/VTR Fallback LRL may be programmed higher or lower than the permanent brady LRL.

The rate will decrease to the highest among the sensor-indicated rate (when applicable), the VRR rate (if enabled), and the ATR/VTR Fallback LRL.

The ATR/VTR Fallback LRL is also the Backup VVI pacing rate during backup pacing in the presence of detected ventricular arrhythmias.

End of ATR Episode

The End of ATR Episode identifies the point when the pulse generator reverts to AV-synchronous operation because the atrial arrhythmia is no longer detected.

With the termination of the arrhythmia, the ATR Exit Count decrements from its programmed value until it reaches 0. When the ATR Exit Count reaches 0, the pacing mode automatically switches to the programmed tracking mode, and AV-synchronous operation is restored.

Ventricular Tachy Response (VTR)

VTR serves as an automatic mode switch for backup VVI pacing in the presence of detected ventricular tachyarrhythmias.

When detection is satisfied in a ventricular tachycardia zone, the pacing mode switches to VVI (BiV) or to Off if the current mode is AAI(R) or Off.

When the mode switches, backup pacing occurs at the programmed ATR/VTR Fallback LRL and uses the programmed ATP ventricular Pulse Width and Amplitude values.

Ventricular Rate Regulation (VRR)

This feature is available in AUTOGEN, DYNAGEN, INOGEN, ORIGEN, INCEPTA, ENERGEN, PUNCTUA, and COGNIS devices.

VRR is designed to reduce the V–V cycle length variability during partially conducted atrial arrhythmias by modestly increasing the ventricular pacing rate. In addition, VRR preserves CRT delivery during conducted atrial arrhythmias.

The VRR algorithm calculates a VRR-indicated pacing interval based on a weighted sum of the current V–V cycle length and the previous VRR-indicated pacing intervals.

- Paced intervals have more influence than sensed intervals such that paced events cause a decrease in the VRR-indicated rate.
- For sensed intervals, the VRR-indicated rate may be increased; however, the influence is tempered by the previous history.
- The VRR-indicated rate is further bound by the LRL and the VRR MPR.

The programmable values for VRR are Min (Minimum), Med (Medium), and Max (Maximum). The programmed value will affect the degree of rate regulation as follows:

- A higher setting will increase CRT pacing more than a lower setting (i.e., Max vs. Med).
- A higher setting will decrease V–V variability more than a lower setting.
- A lower setting will result in a wider range of V–V variability and less ventricular CRT pacing.

NOTE: VRR has the potential to increase CRT delivery during atrial tachyarrhythmias and should be programmed on at the maximum setting to increase the ventricular pacing percent and maximize CRT delivery during conducted atrial tachyarrhythmias.

When VRR is programmed on in tracking modes, it is only active when an ATR mode switch has occurred. Once the tracking mode operation resumes at the termination of the atrial arrhythmia, VRR becomes inactive. In tracking modes where both Rate Smoothing and VRR are

programmed on, Rate Smoothing is disabled when VRR is active during ATR and re-enabled once the ATR terminates.

When programmed on in nontracking modes, VRR is continually active and updates the VRR-indicated pacing rate and the smoothed average on each cardiac cycle.

Ventricular Rate Regulation Maximum Pacing Rate (VRR MPR)

The VRR MPR limits the maximum pacing rate for VRR.

VRR operates between the LRL and the MPR.

Biventricular Trigger

This feature is available in AUTOGEN, DYNAGEN, INOGEN, ORIGEN, INCEPTA, ENERGEN, PUNCTUA, and COGNIS devices.

Biventricular Trigger (BiV Trigger) is designed to promote synchronized RV and LV contractions in the presence of RV sensed events. It does this by pacing the left and right ventricles immediately after any sensed RV event, including any PVCs. When used in conjunction with VRR, BiV Trigger is designed to provide additional CRT support during atrial tachycardias.

Biventricular Trigger operates between the LRL and the MPR. Paces that occur as a result of BiV Trigger are marked as RVP-Tr and LVP-Tr with no LV Offset applied. These triggered events are counted toward RVS and LVP counters.

Biventricular Trigger is separately programmable for normal pacing and ATR Fallback.

NOTE: *If the pulse generator is programmed to RV or LV Only, pacing in both chambers will occur if BiV Trigger is enabled.*

Biventricular Trigger Maximum Pacing Rate (MPR)

The Biventricular Trigger MPR limits the maximum pacing rate that Biventricular Trigger can reach.

Atrial Flutter Response (AFR)

This feature is available in AUTOGEN, DYNAGEN, INOGEN, ORIGEN, INCEPTA, ENERGEN, PUNCTUA, and COGNIS devices.

Atrial Flutter Response is designed to:

- Prevent pacing into the vulnerable period following an atrial sense. Pacing into the vulnerable period could occur if an atrial pace is scheduled soon after a refractory atrial sense.
- Provide immediate nontracking of atrial rates higher than the AFR Trigger Rate.

The nontracking behavior is maintained for as long as atrial events continually exceed the AFR Trigger Rate.

Example: When AFR is programmed to 170 min⁻¹, a detected atrial event inside the PVARP or a previously triggered AFR interval starts an AFR window of 353 ms (170 min⁻¹). Atrial detection inside the AFR is classified as a sense within the refractory period and is not tracked. Atrial tracking may only occur after both PVARP and the AFR window expire. Paced atrial events scheduled inside an AFR window are delayed until the AFR window expires. If there are fewer than 50 ms remaining before the subsequent ventricular pace, the atrial pace is inhibited for the cycle.

NOTE: This feature may override the programmed AV Delay and temporarily alter the effectiveness of CRT due to the effect on AV synchrony.

Ventricular pacing is not affected by AFR and will take place as scheduled. The wide programmable range for AFR Trigger rates allows for appropriate sensing of slow atrial flutters. High-rate atrial sensing may continuously retrigger the AFR window, effectively resulting in behavior similar to the VDI(R) fallback mode.

NOTE: For atrial arrhythmias that meet the programmed AFR rate criteria, using the AFR feature will result in slower ventricular pacing rates.

NOTE: When both AFR and ATR are active in the presence of atrial arrhythmias, nontracking ventricular paced behavior may occur sooner, but the ATR Mode Switch may take longer. This is because the ATR Duration feature counts ventricular cycles for meeting duration and the AFR feature slows the ventricular paced response to fast atrial arrhythmias.

PMT Termination

This feature is available in AUTOGEN, DYNAGEN, INOGEN, ORIGEN, INCEPTA, ENERGEN, PUNCTUA, and COGNIS devices.

PMT Termination detects and attempts to interrupt pacemaker-mediated tachycardia (PMT) conditions.

AV synchrony may be lost for many reasons, including atrial fibrillation, PVCs, PACs, atrial oversensing, or loss of atrial capture. If the patient has an intact retrograde conduction pathway when AV synchrony is lost, the unsynchronized beat may conduct retrograde to the atrium, resulting in premature atrial depolarization. In DDD(R) and VDD(R) pacing modes, the device may detect and track retrograde conducted P-waves that fall outside of PVARP. The repeated cycle of sensing and tracking retrograde conduction is known as PMT, which can result in triggered ventricular pacing rates as high as the MTR. Programming certain refractory periods (e.g., PVARP after PVC) can reduce the likelihood of tracking retrograde events. Rate Smoothing can also be useful in controlling the pulse generator's response to retrograde conduction.

When the pulse generator's response to retrograde conduction has not been controlled by device programming, PMT Termination (when programmed to On) is used to detect and terminate PMT within 16 cycles of onset when the following conditions have been met:

- 16 successive ventricular paces are counted at the MTR following atrial sensed events
- All 16 V–A intervals are within 32 ms (preceding or following) of the second V–A interval measured at MTR during the 16 ventricular paced events (to distinguish Wenckebach behavior from PMT)

When both conditions are met, the pulse generator sets the PVARP to a fixed setting of 500 ms for one cardiac cycle in an attempt to break the PMT. If both conditions are not met, the pulse generator continues to monitor successive ventricular paces for the presence of a PMT.

When PMT Termination is programmed to On, the pulse generator stores PMT episodes in the Arrhythmia Logbook.

NOTE: Although the V–A interval evaluation helps discriminate true PMT (stable V–A intervals) from upper rate behavior due to sinus tachycardia or normal exercise response (typically unstable V–A intervals), it is possible that a patient's intrinsic atrial rate can meet PMT detection criteria. In such cases, if PMT Termination is programmed On, the algorithm will declare the rhythm a PMT and extend PVARP on the 16th cycle.

NOTE: Because retrograde conduction times may vary over a patient's lifetime due to their changing medical condition, occasional programming changes may be necessary.

If retrograde conduction is evident in a stored EGM, you can evaluate the electrogram and/or perform a threshold test to confirm appropriate atrial pacing and sensing. If stored EGMs are not available for review, follow these steps to use the PRM to assist in V–A interval evaluation:

1. From the Tests screen, select the Temp Brady tab.
2. Program an appropriate atrial sensing mode that provides atrial markers (VDD, DDD, or DDI).
3. Program the maximum PVARP to a value shorter than the average retrograde conduction time.

NOTE: *Scientific literature suggests that the average retrograde conduction time is 235 ± 50 ms (with a range of 110–450 ms).¹*

4. Program the LRL to ensure pacing above the intrinsic atrial rate (e.g., 90, 100, 110...).
5. Begin printing the real-time ECG.
6. Select the Start button to activate the temporary parameters.
7. When testing is complete for the specified LRL value, select the Stop button.
8. Stop printing the real-time ECG.
9. Evaluate the ECG strip for V–A conduction (VP followed by an AS). Look for stable and consistent intervals suggestive of retrograde conduction.
 - If retrograde conduction was identified, compare the retrograde V–A interval time to the programmed refractory period. Consider programming PVARP to the appropriate value so that the retrograde event is not tracked.
 - If retrograde conduction was not identified, the PMT episode may be a result of normal upper rate behavior. Review Histograms to see how often the rate is at the MTR, and consider raising the MTR (if clinically appropriate).
10. If necessary, repeat this procedure with different LRL values, as retrograde conduction may occur at different rates.

RATE ENHANCEMENTS

Tracking Preference

This feature is available in AUTOGEN, DYNAGEN, INOGEN, ORIGEN, INCEPTA, ENERGEN, PUNCTUA, and COGNIS devices.

Tracking Preference is designed to maintain atrial-tracked ventricular pacing in DDD(R) and VDD (R) modes by identifying atrial events for tracking that should be tracked but fall within PVARP. This feature supports CRT delivery for atrial rates below but near the MTR; otherwise, therapy might be inhibited.

Atrial events can fall within PVARP when a patient has a combination of a long intrinsic intracardiac AV interval and a long PVARP. If two successive cycles occur in which a sensed RV event is preceded by an atrial sensed event in PVARP, the pulse generator shortens PVARP until normal atrial-tracked ventricular pacing is established. The PVARP is shortened enough for tracking to occur on any atrial event that occurs after the A-Blank after RV-Sense cross-chamber

1. Furman S, Hayes D.L., Holmes D.R., A Practice of Cardiac Pacing. 3rd ed. Mount Kisco, New York: Futura Publishing Co.; 1993:74-75.

blanking period ends. When atrial tracking is re-established, the AV Delay may be extended to prevent violation of the MTR. The shortened PVARP remains in effect until a ventricular pace occurs at the programmed AV Delay. By programming Tracking Preference to On, continuous CRT is delivered at rates below MTR-rates which otherwise might be inhibited when the sum of PVARP and the intrinsic intracardiac AV interval is longer than the MTR interval.

The effect of Tracking Preference on atrial rates is illustrated below (Figure 4–33 Tracking Preference on atrial events that should be tracked but fall within PVARP on page 4-53).

NOTE: *Tracking Preference is inhibited if the atrial rate interval is greater than or equal to the MTR interval. This prevents the tracking of potentially pathological atrial rates and PMT.*

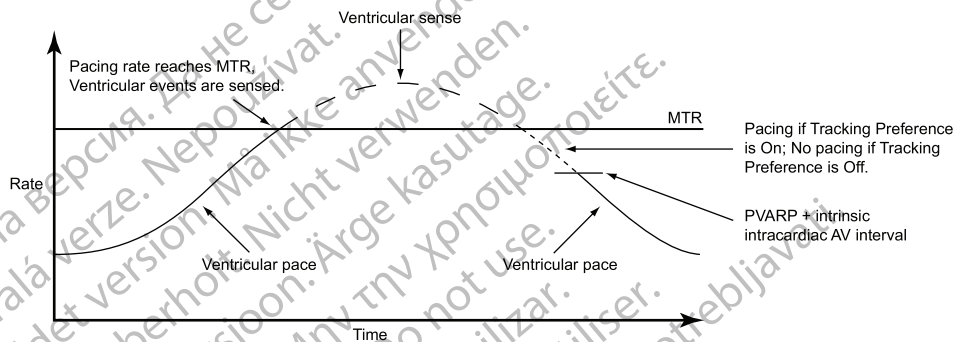

Figure 4–33. Tracking Preference on atrial events that should be tracked but fall within PVARP

Rate Hysteresis

This feature is available in AUTOGEN, DYNAGEN, INOGEN, ORIGEN, INCEPTA, ENERGEN, PUNCTUA, and COGNIS devices.

Rate Hysteresis can improve device longevity by reducing the number of pacing stimuli. This feature is available in DDD and AAI modes and is activated by a single nonrefractory, atrial sensed event.

In DDD and AAI modes, Hysteresis is deactivated by a single atrial pace at the Hysteresis Rate. In DDD mode, Hysteresis is deactivated by an atrial rate above the MTR.

When Rate Smoothing Down is enabled, Rate Hysteresis remains in effect until pacing occurs at the Hysteresis Rate. This allows Rate Smoothing to control the transition to the Hysteresis Rate.

Hysteresis Offset

Hysteresis Offset is used to lower the escape rate below the LRL when the pulse generator senses intrinsic atrial activity.

If intrinsic activity below the LRL occurs, then Hysteresis Offset allows inhibition of pacing until the LRL minus Hysteresis Offset is reached. As a result, the patient might benefit from longer periods of sinus rhythm.

Search Hysteresis

When Search Hysteresis is enabled, the pulse generator periodically lowers the escape rate by the programmed Hysteresis Offset in order to reveal potential intrinsic atrial activity below the LRL. The programmed number of search cycles must be consecutively atrial paced for a search to occur.

Example: At a rate of 70 min⁻¹ and a search interval of 256 cycles, a search for intrinsic atrial activity would occur approximately every 3.7 minutes (256 ÷ 70 = 3.7).

During Search Hysteresis, the pacing rate is lowered by the Hysteresis Offset for up to 8 cardiac cycles. If intrinsic activity is sensed during the search period, Hysteresis will remain active until an atrial pace occurs at the hysteresis offset rate.

Rate Smoothing is disabled during the search cycles. If no intrinsic atrial activity is detected during the 8-cycle search, the pacing rate is brought up to the LRL. Rate Smoothing Up, if enabled, controls the pacing rate increase.

Rate Smoothing

This feature is available in AUTOGEN, DYNAGEN, INOGEN, ORIGEN, INCEPTA, ENERGEN, PUNCTUA, and COGNIS devices.

Rate Smoothing controls the pulse generator's response to atrial and/or ventricular rate fluctuations that cause sudden changes in pacing intervals. Rate Smoothing is an important enhancement to ATR because it can significantly reduce the rate fluctuations associated with the onset and cessation of atrial arrhythmias.

Without Rate Smoothing, a sudden, large atrial rate increase will cause a simultaneous sudden increase in the paced ventricular rate as high as the programmed MTR. Patients who experience large variations in their ventricular paced rate can feel symptomatic during these episodes. Rate Smoothing can prevent these sudden rate changes and the accompanying symptoms (such as palpitations, dyspnea, and dizziness).

In a normal conduction system, limited cycle-to-cycle rate variations occur. However, the paced rate can change dramatically from one beat to the next in the presence of any of the following:

- Sinoatrial disease such as sinus pause or arrest, sinoatrial block, and brady-tachy syndrome
- PACs and/or PVCs
- Pacemaker Wenckebach
- Intermittent, brief, self-terminating SVTs, and atrial flutter/fibrillation
- Retrograde P-waves
- Pulse generator sensing of myopotential signals, EMI, crosstalk, etc.

In single-chamber modes, Rate Smoothing operates between:

- The LRL and the MPR when programmed VVI or AAI
- The LRL and the MSR when programmed VVIR or AAIR

In dual-chamber modes, Rate Smoothing operates between:

- The LRL and the greater of the MSR or MTR when programmed DDD(R) or VDD(R)
- The LRL and MPR when programmed to DDI
- The LRL and MSR when programmed to DDIR

Rate Smoothing is also applicable between the Hysteresis Rate and LRL when Hysteresis is active, except during Search Hysteresis.

When Rate Smoothing is programmed to On, it is functional except:

- During the 8 cycles of rate Search Hysteresis

- During ATR Fallback until fallback reaches the ATR LRL, the sensor-indicated rate, or the VRR interval
- During VRR when active
- Upon triggering PMT Termination
- Immediately following programmed LRL increases
- When the intrinsic rate is above the MTR
- When Tracking Preference is active

Programmable Values

Rate Smoothing values are a percentage of the RV R–R interval (3% to 25% in 3% increments) and can be independently programmed for:

- Increase—Rate Smoothing Up
- Decrease—Rate Smoothing Down
- Off

The pulse generator stores the most recent R–R interval in memory. R-waves may be either intrinsic or paced. Based on this R–R interval and the programmed Rate Smoothing value, the device limits the variation in paced rate on a beat to beat basis.

It is important to ascertain the patient's physiologic cycle-to-cycle variation and program the Rate Smoothing parameter to a value that protects against pathologic interval changes, yet allows physiologic interval changes in response to increases in activity or exercise.

Rate Smoothing Up

Rate Smoothing Up controls the largest pacing rate increase allowed when the intrinsic or sensor rate is increasing.

NOTE: *Rate Smoothing Up will transiently modify the programmed AV Delay. This could change the effectiveness of the AV Delay recommended with SmartDelay optimization.*

When Rate Smoothing Up is programmed On, CRT is compromised during episodes of atrial rate increases that exceed the programmed value.

- For patients with AV block, this occurs because Rate Smoothing prolongs the AV Delay from the optimal setting as it controls the biventricular pacing rate while the atrial rate increases.
- For patients with normal AV conduction, biventricular stimulation (CRT) may be inhibited in one or more cycles during the Rate Smoothing operation because intrinsic AV conduction may occur during the prolonged AV Delay and inhibit ventricular pacing.

While the effect of the Rate Smoothing Up operation may only be transient and its impact on CRT minimal, consider the following recommendations when programming this parameter On:

- Address only patient-specific, sudden atrial rate increases
- Use the highest value that can achieve the desired control because the higher the value, the less the impact on the AV Delay extension

Rate Smoothing Down

Rate Smoothing Down controls the largest pacing rate decrease allowed when the intrinsic or sensor rate is decreasing.

CRT delivery is not altered by programming Rate Smoothing Down On. However, it is important to consider that when Rate Smoothing Down is On in DDD(R) mode, atrial pacing will occur during the downward Rate Smoothing operation. The AV Delay for optimal CRT may be different during atrial pacing than during intrinsic sinus rhythm.

NOTE: When Rate Smoothing Down is programmed On and Rate Smoothing Up is programmed Off, the pulse generator will automatically prevent fast intrinsic beats (e.g., PVCs) from resetting the Rate Smoothing Down escape rate any faster than 12% per cycle.

Rate Smoothing Maximum Pacing Rate (MPR)

The Rate Smoothing Maximum Pacing Rate places a limit on the maximum pacing rate that Rate Smoothing can reach.

The Rate Smoothing Down parameter requires a programmed MPR when in AAI, VVI, or DDI. Rate Smoothing will then be used only between the MPR and the LRL or the Hysteresis Rate (if applicable).

When both VRR and Rate Smoothing are programmed on in the VVI(R) or DDI(R) mode, VRR will have priority.

Rate Smoothing Example Based on a Dual-Chamber Tracking Mode

Based on the most recent R–R interval stored in memory and the programmed Rate Smoothing value, the pulse generator sets up the two synchronization windows for the next cycle: one for the atrium and one for the ventricle. The synchronization windows are defined below:

Ventricular synchronization window: previous R–R interval \pm Rate Smoothing value

Atrial synchronization window: (previous R–R interval \pm Rate Smoothing value) - AV Delay

The following example explains how these windows are calculated (Figure 4–34 Rate smoothing synchronization window on page 4-57):

- Previous R–R interval = 800 ms
- AV Delay = 150 ms
- Rate Smoothing Up = 9%
- Rate Smoothing Down = 6%

The windows would be calculated as follows:

Ventricular Synchronization Window = 800 - 9% to 800 + 6% = 800 ms - 72 ms to 800 ms + 48 ms = 728 ms to 848 ms

Atrial Synchronization Window = Ventricular Synchronization Window - AV Delay = 728 ms - 150 ms to 848 ms - 150 ms = 578 ms to 698 ms

The timing for both windows is initiated at the end of every R–R interval (RV event or LV paces when the Pacing Chamber is programmed to LV Only).

If paced activity is to occur, it must occur within the appropriate synchronization window.

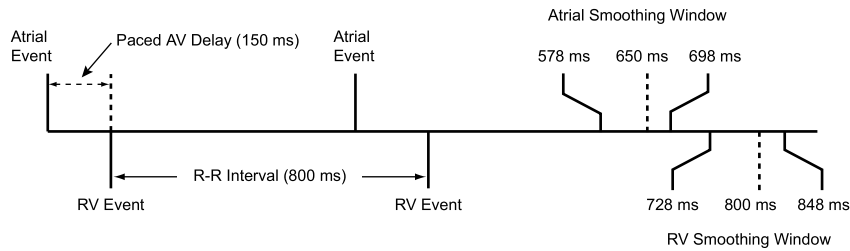

Figure 4-34. Rate smoothing synchronization window

LEAD CONFIGURATION

This feature is available in AUTOGEN, DYNAGEN, INOGEN, ORIGEN, INCEPTA, ENERGEN, PUNCTUA, and COGNIS devices.

The pulse generator has independently programmable lead configurations for the following:

- Atrium
- Right Ventricle
- Left Ventricle

The atrial and RV leads are set to Bipolar pacing and sensing. The atrial lead has the option of being programmed Off.

The input impedance is $> 100 \text{ K}\Omega$ for each sense/pace electrode pair.

CAUTION: If the Lead Configuration is programmed to Bipolar when a unipolar lead is implanted, pacing will not occur.

Left Ventricular Electrode Configuration

This feature is available in AUTOGEN, DYNAGEN, INOGEN, ORIGEN, INCEPTA, ENERGEN, PUNCTUA, and COGNIS devices.

The LV Electrode Configuration provides programmable options for LV lead pacing and sensing via the Lead Settings screen (accessible from the Normal Settings screen).

CAUTION: Proper programming of the LV coronary venous Lead Configuration is essential for proper LV lead function. Program the Lead Configuration in accordance with the number of electrodes on the LV lead; otherwise, erratic LV sensing, loss of LV pacing, or ineffective LV pacing might occur.

The following programming options are available for devices with an IS-1 or LV-1 left ventricular lead port:

- Dual—used when an LV lead with two electrodes is implanted
- Single—used when an LV lead with only one electrode is implanted
- None—used when an LV lead is not implanted

NOTE: The nominal LV Electrode Configuration is None, which, along with the nominal Ventricular Pacing Chamber of BiV, results in a parameter interaction. This is intended behavior to ensure the clinician selects an appropriate LV Electrode Configuration (dual or single) for the implanted LV lead.

For devices with an IS4 left ventricular lead port, the LV Electrode Configuration is automatically set to Quadripolar.

These pulse generators are intended for use with an LV lead; however, there may be clinical situations such as those described below in which an LV lead is not used:

- The LV lead cannot be positioned, and a decision is made to temporarily use the pulse generator without an LV lead (plug the unused LV port).
- The LV lead dislodges to a suboptimal position, and a decision is made to leave the lead implanted and connected but not use it.

The pulse generator cannot detect whether an LV lead is present or absent. Therefore, if an LV lead is not used, consider the following programming adjustments, which can help to prevent reporting of irrelevant LV diagnostic information, minimize storage of LV information (e.g., counters, EGMs, markers, intervals), minimize diaphragm stimulation, and improve device longevity:

NOTE: *If these steps are performed in a different sequence, the PRM may display warning messages and certain steps may not be available.*

1. Program BiV Trigger to Off under both the ATR section and the Ventricular Regulation section of the Atrial Tachy Therapy Settings screen.
2. Program LV Amplitude and LV Pulse Width to the minimum value for both Normal Brady and Post-Therapy pacing.
3. Program the Ventricular Pacing Chamber to RV Only.
4. Turn off LV sensing:
 - a. For devices with an IS-1 or LV-1 left ventricular lead port:
 - i. Change the LV Electrode Configuration to Single or Dual.
 - ii. Program LV Sense to Off.
 - iii. Program the LV Electrode Configuration to None.
 - b. For devices with an IS4 left ventricular lead port:
 - i. Select the Disable Sensing checkbox on the LV Sense selection screen.
 - ii. Select the Accept button.
 - iii. Program the device.
5. Program the daily lead measurements for LV Intrinsic Amplitude and LV Impedance to Off.

When this programming sequence is followed, LV pacing and sensing are turned Off, and the following are unavailable:

- LV electrograms
- LV markers
- LV intervals
- LV Offset
- LV-Blank after A-Pace cross-chamber blanking period
- SmartDelay optimization (non-Quadripolar devices)
- LV daily measurements

NOTE: Some features (e.g., ATR Mode Switch, ATP, and Electrocautery Protection Mode) temporarily use BiV pacing (regardless of LV Lead Configuration), which will add LV data to the counters, electrograms, markers, and intervals.

Any time a change is made to the Electrode Configuration, it is important to verify lead system baseline measurements to ensure optimal functioning.

The programmed selections are reflected in the Electrode Configuration illustration on the programmer Leads Setting screen (Figure 4–35 Heart LV, and RV lead in situ on page 4-59). Illustrations will dynamically adjust on the programmer screen to reflect the currently selected LV Pace and LV Sense configurations.

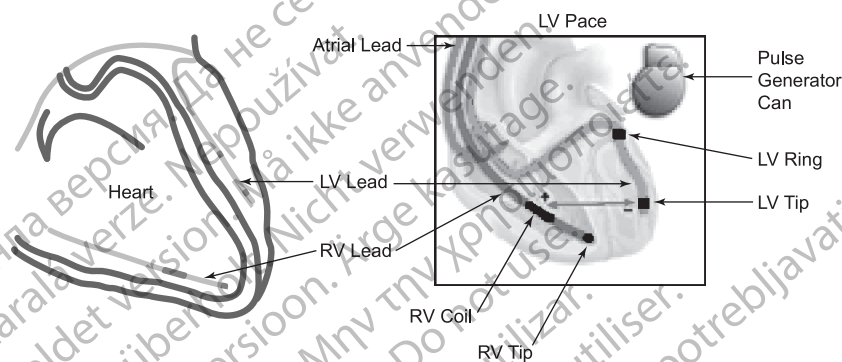

Left illustration: heart with LV and RV leads. Right illustration: leads on the programmer screen.

Figure 4–35. Heart LV, and RV lead in situ

LV Pace and Sense Configurations

Multiple LV pace and sense configurations are available for the lead, allowing you to change the pacing or sensing vectors for increased signal selection. For devices with an IS-1 or LV-1 left ventricular lead port, additional programming options are available when a dual-electrode LV lead is implanted and the corresponding Electrode Configuration is programmed to Dual. Additionally, LV sensing can be disabled by selecting Off as the LV Sense configuration.

Illustrations of pace and sense configurations are shown on the programmer Leads Setting screen.

Quadripolar Devices

For devices with an IS4 left ventricular lead port, 17 pacing configurations and 8 sensing configurations are available. A table of programmable options is provided within the LV Sense and LV Pace selections.

Additionally, the LV VectorGuide feature is available to streamline the testing required to determine the optimal LV Pacing Lead Configuration for each individual patient. The clinician can quickly evaluate multiple Quadripolar LV pacing vectors and then program the desired configuration ("LV VectorGuide" on page 5-17).

For the LV Pace configuration, the pacing stimulus travels between the cathode (negative [-] electrode) and the anode (positive [+] electrode). Follow these steps to program the LV Pace configuration:

1. Determine the desired Cathode (-) which is listed on the left-hand side of the table.
2. Determine the desired Anode (+) which is listed at the top of the table.

3. Select the option in the table which corresponds to the desired Cathode and Anode combination.

The illustration to the right of the table will dynamically adjust to reflect the currently selected LV configuration. For example, if LVTip1 is selected as the Cathode and RV is selected as the Anode, this configuration will be reflected in the associated illustration to the right of the table (Figure 4–36 Pacing lead configuration screen for Quadripolar devices on page 4-60).

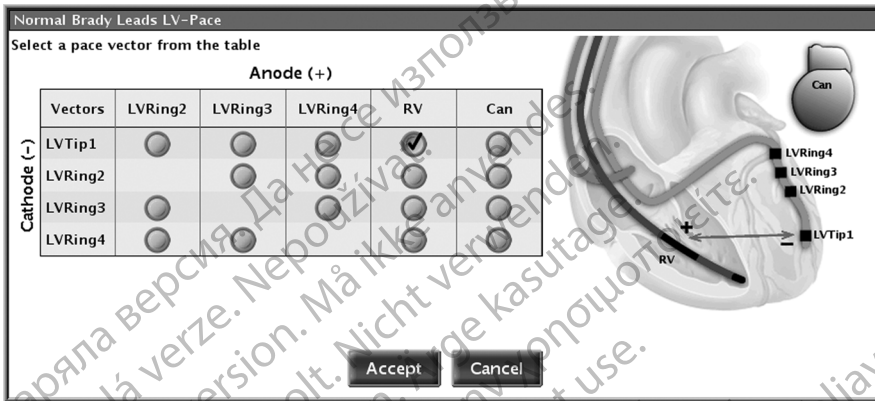

Figure 4–36. Pacing lead configuration screen for Quadripolar devices

For the LV Sense configuration, the patient's intrinsic cardiac signals will be sensed between Electrode 1 and Electrode 2. Select the option in the table which corresponds to the desired Electrode 1 and Electrode 2 combination. The illustration to the right of the table will dynamically adjust to reflect the currently selected LV configuration. For example, if LVTip1 is selected as Electrode 1 and LVRing2 is selected as Electrode 2, this configuration will be reflected in the associated illustration to the right of the table (Figure 4–37 Sensing lead configuration screen for Quadripolar devices on page 4-60). Additionally, LV sensing can be turned off by selecting the Disable Sensing checkbox.

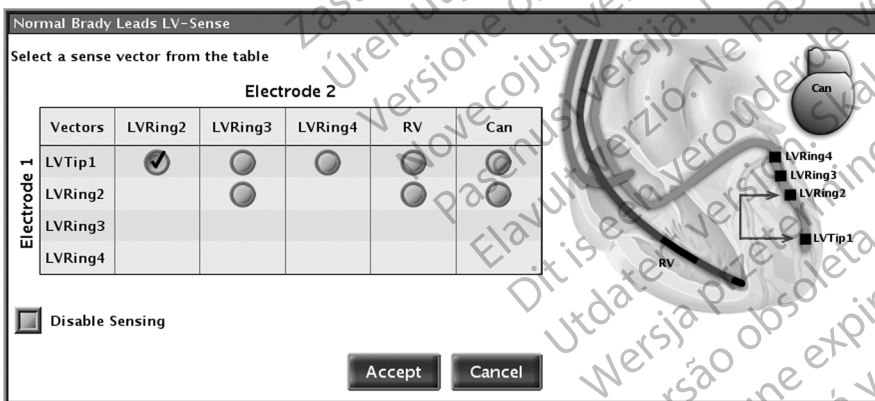

Figure 4–37. Sensing lead configuration screen for Quadripolar devices

LV Electrograms

Real-time LV EGMs can be used to assess LV lead performance and to assist in optimizing some programmable parameters (e.g., AV Delay, LV Offset).

LV EGMs and associated LV event markers are available for display or printing in all sense configurations.

AV DELAY

AV Delay is the programmable time period from the occurrence of either a paced or sensed right atrial event to a paced RV event when the Ventricular Pacing Chamber is programmed to BiV or RV Only.

When the Pacing Chamber is programmed to LV Only, AV Delay is the period from a paced or sensed atrial event to a paced LV event.

AV Delay is designed to help preserve the heart's AV synchrony. If a sensed right ventricular event does not occur during the AV Delay following an atrial event, the pulse generator delivers a ventricular pacing pulse when the AV Delay expires.

AV Delay can be programmed to one or both of the following operations:

- Paced AV Delay
- Sensed AV Delay

CAUTION: To ensure a high percentage of biventricular pacing, the programmed AV Delay setting must be less than the patient's intrinsic PR interval.

AV Delay is applicable in DDD(R), DDI(R), DOO or VDD(R) modes.

Paced AV Delay

This feature is available in AUTOGEN, DYNAGEN, INOGEN, ORIGEN, INCEPTA, ENERGEN, PUNCTUA, and COGNIS devices.

Paced AV Delay corresponds to the AV Delay following an atrial pace.

The Paced AV Delay setting should be individualized for each patient to ensure consistent CRT delivery. Several methods are available to determine the Paced AV Delay setting, including:

- Intrinsic QRS duration assessment
- Echocardiogram evaluation
- Pulse pressure monitoring
- SmartDelay optimization

Since optimization of the Paced AV Delay can significantly influence CRT effectiveness, consider using methods that demonstrate the hemodynamic impact of different Paced AV Delay settings, such as echocardiography or pulse pressure monitoring.

When the minimum AV Delay value is less than the maximum AV Delay value, then the Paced AV Delay is scaled dynamically according to the current pacing rate. Dynamic AV Delay provides a more physiologic response to rate changes by automatically shortening the Paced AV Delay or Sensed AV Delay with each interval during an increase in atrial rate. This helps minimize the occurrence of large rate changes at the upper rate limit and allows one-to-one tracking at higher rates.

When using Dynamic AV Delay, consider evaluating the Paced AV Delay in effect when the patient has an elevated heart rate to ensure that CRT is still effective.

The pulse generator automatically calculates a linear relationship based on the interval length of the previous A–A or V–V cycle (depending on the previous event type) and the programmed values for the following:

- Minimum AV Delay

- Maximum AV Delay
- LRL
- MTR
- MSR
- MPR

The Dynamic AV Delay is not adjusted following a PVC or when the previous cardiac cycle was limited by the MTR.

If the atrial rate is at or below the LRL (e.g., hysteresis), the maximum AV Delay is used. If the atrial rate is at or above the higher of the MTR, MSR, or MPR, the programmed minimum AV Delay is used.

When the atrial rate is between the LRL and the higher of the MTR, MSR, and MPR, the pulse generator calculates the linear relationship to determine the Dynamic AV Delay.

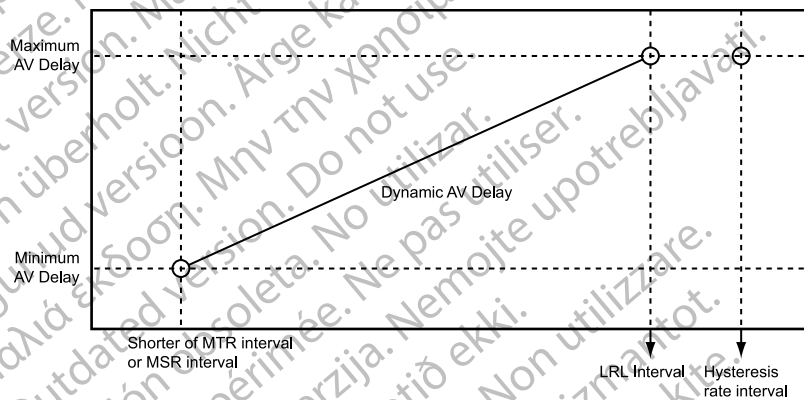

Figure 4-38. Dynamic AV Delay

The AV Delay may be programmed to either a fixed or dynamic value as follows:

- Fixed AV Delay—occurs when Paced AV Delay minimum and maximum values are equal
- Dynamic AV Delay—occurs when Paced AV Delay minimum and maximum values are not equal

Sensed AV Delay

This feature is available in AUTOGEN, DYNAGEN, INOGEN, ORIGEN, INCEPTA, ENERGEN, PUNCTUA, and COGNIS devices.

Sensed AV Delay corresponds to the AV Delay after a sensed atrial event.

Sensed AV Delay may be programmed to a value shorter than or equal to the Paced AV Delay. A shorter value is intended to compensate for the difference in timing between paced atrial events and sensed atrial events (Figure 4-39 Sensed AV Delay on page 4-63).

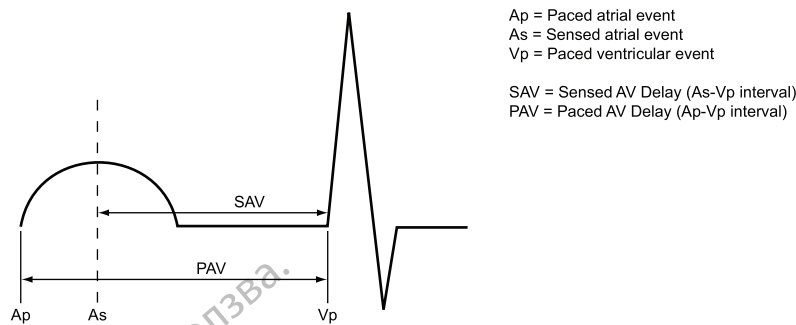

Figure 4-39. Sensed AV Delay

The hemodynamic impact of the Sensed AV Delay depends on the appropriateness of the timing between the atrial and ventricular contractions. Atrial pacing initiates atrial electrical excitation, whereas atrial sensing can only occur after the onset of spontaneous atrial excitation. The delay between initiation and sensing depends on the lead location and conduction. As a result, when Sensed AV Delay is programmed to the same value as Paced AV Delay, the hemodynamic AV interval will differ between paced and sensed atrial events.

When the DDD(R) mode is used to deliver biventricular stimulation (CRT), it may be necessary to program different Paced and Sensed AV Delay settings to optimize CRT during normal sinus rhythm and during atrial pacing because atrial pacing may prolong the interatrial delay. The prolonged interatrial delay may require a longer Paced AV Delay to achieve an optimal timing relationship between left atrial activation and biventricular pacing. The interatrial delay may be estimated by the longest P-wave duration.

When the device is programmed to DDD(R), it is recommended that the patient be tested to determine the optimal AV Delay during atrial sensing and atrial pacing. If the optimal AV Delays are different, this can be reflected by programming different Paced AV Delay and Sensed AV Delay parameter settings.

Using Sensed AV Delay with Paced AV Delay—Fixed

When Paced AV Delay is programmed to a fixed value, then the Sensed AV Delay will be fixed at the programmed Sensed AV Delay value.

Using Sensed AV Delay with Paced AV Delay—Dynamic

When Paced AV Delay is programmed as dynamic, then the Sensed AV Delay will also be dynamic.

Dynamic Sensed AV Delay and Paced AV Delay are based on the atrial rate. To reflect the shortening of the PR interval during periods of increased metabolic demand, the AV Delay shortens linearly from the programmed (maximum) value at the LRL (or hysteresis rate) to a value determined by the ratio of minimum and maximum AV Delay at the higher of the MTR, MSR, or MPR (Figure 4-40 Dynamic and Sensed AV Delay function on page 4-64). When Dynamic AV Delay is used, if the maximum Sensed AV Delay value is programmed as shorter than the maximum Paced AV Delay value, then the minimum Sensed AV Delay value will also be shorter than the minimum Paced AV Delay value.

NOTE: The minimum Sensed AV Delay value is programmable only in VDD(R) mode.

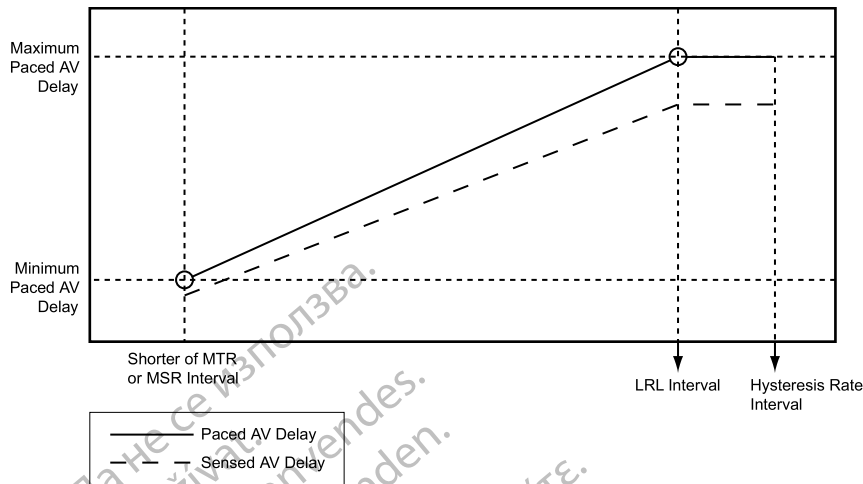

Figure 4-40. Dynamic and Sensed AV Delay function

SmartDelay Optimization

This feature is available in AUTOGEN, DYNAGEN, INOGEN, INCEPTA, ENERGEN, and COGNIS devices.

The SmartDelay optimization feature quickly (< 2.5 minutes) provides recommended settings for programming paced and sensed AV Delay based on the measurement of intrinsic AV intervals. The objective of the feature is to recommend AV delays that provide optimally timed CRT, which maximizes contractile function.

Clinical data regarding hemodynamic performance of this feature relative to other AV Delay optimization methods shows that the SmartDelay optimization algorithm recommended AV delays that maximized global contractile function as measured independently by LV dP/dt_{max} . LV dP/dt_{max} is considered an index for global ventricular contractile function and pumping efficiency.

The SmartDelay optimization test evaluates right and left ventricular response to both atrial sensed and paced events to determine suggested settings for the following:

- Paced AV Delay
- Sensed AV Delay
- Pacing Chamber

These suggested settings can be used when programming the pulse generator for CRT. In addition to the parameters suggested by SmartDelay, the following parameters are also displayed on the PRM:

- LV Offset (when applicable), which is a separately programmable feature that you can enter manually. If you manually adjust LV Offset after running SmartDelay optimization, you will need to adjust the AV Delay either by running SmartDelay optimization again or manually reprogramming the AV Delay. SmartDelay takes the LV Offset into account as follows:
 - SmartDelay uses simple arithmetic to account for the programmed LV Offset in the Paced and Sensed AV Delay recommendations it provides. For example, if the SmartDelay suggested AV Delay (which starts at the atrial event and ends at the left ventricular pace) is 150 ms and the programmed LV Offset is -20 ms, then the SmartDelay feature will adjust its recommendation to 170 ms, since the AV Delay feature is programmed from the atrial event to the right ventricular pace.
 - SmartDelay maintains the currently programmed LV Offset with the following exceptions:
 - (1) If SmartDelay cannot collect sufficient intrinsic events, nominal settings that include

an LV Offset of zero are suggested. (2) If SmartDelay recommends an AV Delay and LV Offset that together exceed the maximum programmable AV Delay of 300 ms, SmartDelay will suggest a reduced LV Offset. (3) If the currently programmed LV Offset is greater than 0 ms, an LV Offset of zero is suggested.

NOTE: Before making a programming change, it is important to assess whether the suggested settings are appropriate for the patient.

The SmartDelay optimization screen is shown below (Figure 4–41 SmartDelay optimization screen on page 4-65).

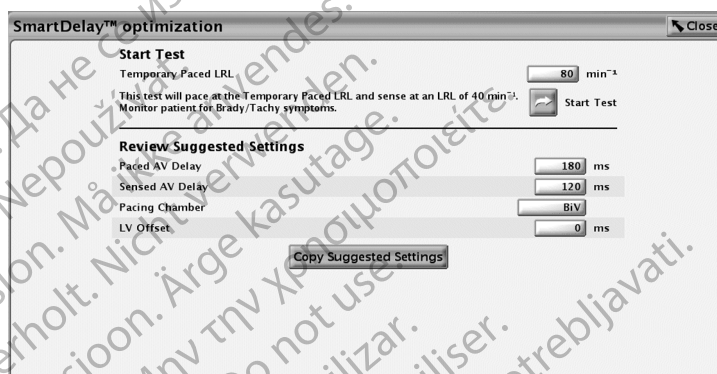

Figure 4–41. SmartDelay optimization screen

NOTE: Tachy therapy is disabled while the test is in progress.

SmartDelay optimization automatically switches to a unipolar sensing configuration for the duration of the test. The test runs automatically when Start Test is pressed. The SmartDelay optimization test will not run under the following conditions:

- During the post-therapy period
- When the LV Electrode Configuration is programmed to None for devices with an IS-1 or LV-1 left ventricular lead port
- During an ATR Mode Switch
- During a tachycardia episode as determined by the pulse generator detection criteria

NOTE: When collecting atrial sensed events during the test, backup DDD pacing is provided at 40 min⁻¹.

NOTE: When collecting atrial paced events, backup DDD pacing is provided at the temporary LRL, which can be selected from the SmartDelay optimization screen. This temporary LRL is nominally set to 80 min⁻¹.

NOTE: It is necessary to increase temporary paced LRL 10 to 15 min⁻¹ higher than the intrinsic atrial rate to achieve paced AV interval measurements.

Follow these steps to run the SmartDelay optimization test.

1. From the Normal Settings screen, select the Mode.
 - In DDD(R) mode, the recommendation is for both Paced AV Delay and Sensed AV Delay.
 - In VDD(R) mode, the recommended AV Delay is the Sensed AV Delay; the Paced AV Delay does not apply.

When changing modes from DDD(R) to VDD(R) or vice versa, it is important to rerun the SmartDelay optimization test.

2. Select the SmartDelay optimization button.
3. Enter the temporary paced LRL value or use the default value of 80 min⁻¹.
4. Maintain telemetry throughout the test.
5. Before beginning the test, advise the patient to remain still and to avoid talking during the test.
6. Press the Start Test button. A notification window indicates that the test is in progress. If it is necessary to cancel the test, select the Cancel Test button.

NOTE: *The test is automatically cancelled if a STAT PACE, STAT SHOCK, or DIVERT THERAPY command is selected.*

7. When the test is complete, the suggested settings appear. For ease in programming, select the Copy Suggested Settings button to transfer the suggested settings to the Normal Brady and CRT Settings screen.

NOTE: *If testing fails, the reason for test failure will be provided.*

REFRACTORY

This feature is available in AUTOGEN, DYNAGEN, INOGEN, ORIGEN, INCEPTA, ENERGEN, PUNCTUA, and COGNIS devices.

Refractory periods are the intervals following paced or sensed events during which the pulse generator is not inhibited or triggered by detected electrical activity. They suppress (or prevent) oversensing of pulse generator artifacts and evoked responses following a pacing pulse. They also promote appropriate sensing of a single, wide, intrinsic complex and prevent the sensing of other intrinsic signal artifacts (e.g., a T-wave or far-field R-wave).

Refer to more information about refractory periods ("Calculating Rates and Refractory Periods" on page 2-5).

NOTE: *Rate Adaptive Pacing is not inhibited during refractory periods.*

A-Refractory - PVARP

PVARP is defined according to the pacing mode:

- Single-chamber atrial modes: AAI(R)—the time period after a sensed or paced atrial event when an atrial sense event does not inhibit an atrial pace.
- Dual-chamber modes: DDD(R), DDI(R), VDD(R)—the time period after a sensed or paced RV event (or LV pace when the Pacing Chamber is programmed to LV Only) when an atrial event does not inhibit an atrial pace or trigger a ventricular pace. The Atrial Refractory period prevents the tracking of retrograde atrial activity initiated in the ventricle.

PVARP can be programmed to a fixed value or to a dynamic value calculated based on the previous cardiac cycles. To program a fixed PVARP, set the minimum and maximum to the same value. PVARP will automatically be dynamic if the minimum value is less than the maximum value.

For heart failure patients with intact AV conduction, a long intrinsic intracardiac AV interval and a long programmed PVARP can cause the loss of atrial tracking below the MTR, resulting in the

loss of biventricular stimulation (CRT). If an atrial event, such as a PAC or a P-wave that immediately follows a PVC, falls into PVARP, it will not be tracked. This allows for AV conduction of an intrinsic ventricular event, which restarts PVARP. Unless the next atrial event occurs outside of PVARP, it too will not be tracked, and another intrinsic AV-conducted ventricular event will occur, again restarting PVARP. This pattern can continue until an atrial event is finally sensed outside of PVARP (Figure 4–42 Atrial sensed event in PVARP on page 4-67).

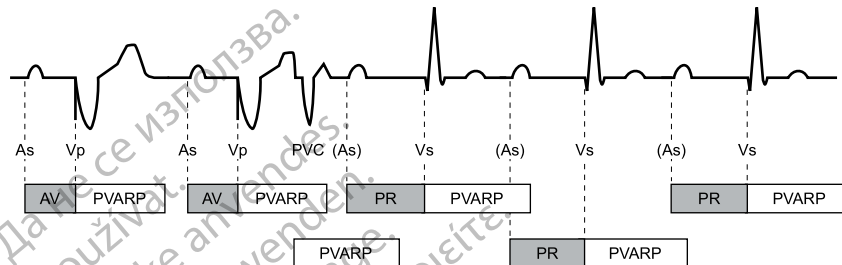

Figure 4–42. Atrial sensed event in PVARP

If you believe a loss of atrial tracking below the MTR is occurring, program Tracking Preference to On. If the loss of CRT below MTR continues to be a problem or if Tracking Preference is not used, consider reprogramming a shorter PVARP.

For heart failure patients with second- and third-degree AV block, programming long Atrial Refractory periods in combination with certain AV Delay periods can cause 2:1 block to occur abruptly at the programmed MTR.

In DDD(R) and VDD(R) pacing modes, the pulse generator may detect retrograde conduction in the atrium, causing triggered ventricular pacing rates as high as the MTR (i.e., PMT). Retrograde conduction times may vary over a patient's lifetime as a function of changing autonomic tone. If testing does not reveal retrograde conduction at implantation, it may still occur at a later time. This problem can usually be avoided by increasing the atrial refractory period to a value that exceeds the retrograde conduction time.

In controlling the pulse generator's response to retrograde conduction, it may also be useful to program the following:

- PVARP after PVC
- PMT Termination
- Rate Smoothing

Dynamic PVARP

Programming of Dynamic PVARP and Dynamic AV Delay optimizes the sensing window at higher rates, allowing upper rate behavior (e.g., 2:1 block and pacemaker Wenckebach) in DDD(R) and VDD(R) modes to be significantly reduced, even at higher MTR settings. At the same time, Dynamic PVARP reduces the likelihood of PMTs at lower rates. Dynamic PVARP also reduces the likelihood of competitive atrial pacing.

The pulse generator automatically calculates the Dynamic PVARP using a weighted average of the previous cardiac cycles. This results in a shortening of the PVARP in a linear fashion as the rate increases. When the average rate is between the LRL and the MTR or applicable upper rate limit, the pulse generator calculates the Dynamic PVARP according to the linear relationship shown (Figure 4–43 Dynamic PVARP on page 4-68). This relationship is determined by the programmed values for Minimum PVARP, Maximum PVARP, the LRL, and the MTR or applicable upper rate limit.

CAUTION: Programming minimum PVARP less than retrograde V–A conduction may increase the likelihood of a PMT.

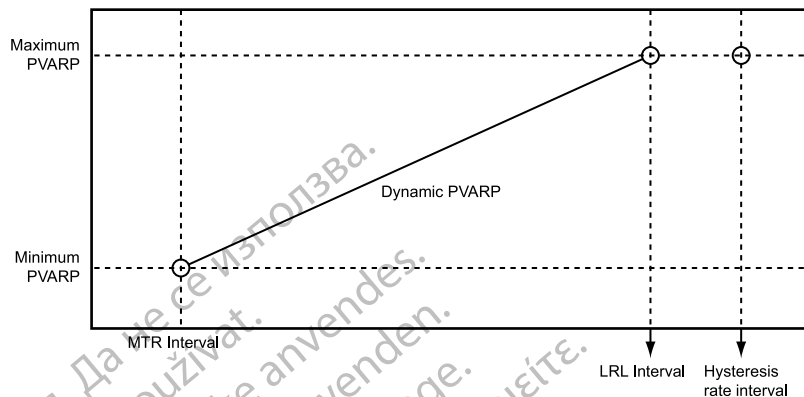

Figure 4-43. Dynamic PVARP

Maximum PVARP

If the average rate is equal to or lower than the LRL (e.g., hysteresis), the Maximum PVARP is used.

Minimum PVARP

If the average rate is equal to or higher than the MTR interval, the programmed Minimum PVARP is used.

PVARP after PVC

PVARP after PVC is designed to help prevent PMT due to retrograde conduction, which can occur due to a PVC.

When the pulse generator detects a sensed RV event without detecting a preceding atrial sensed event (refractory or non-refractory) or delivering an atrial pace, the Atrial Refractory period automatically extends to the programmed PVARP after PVC value for one cardiac cycle. After a PVC is detected, the timing cycles reset automatically. PVARP extends no more frequently than every other cardiac cycle.

The pulse generator automatically extends the PVARP to the PVARP after PVC value for one cardiac cycle in these additional situations:

- If an atrial pace is inhibited due to Atrial Flutter Response
- After a ventricular escape pace that is not preceded by an atrial sense in VDD(R) mode
- When the device transitions from a non-atrial tracking mode to an atrial tracking mode (e.g., exits ATR Fallback, transitions from temporary non-atrial tracking mode to permanent atrial tracking mode)
- When the device returns from Electrocautery Protection Mode or MRI Protection Mode to an atrial tracking mode

For heart failure patients with intact AV conduction, PVARP after PVC has the potential to cause inhibition of CRT if the atrial cycle length is shorter than the intrinsic intracardiac AV interval (PR interval) + PVARP. If this occurs, program Tracking Preference to On in conjunction with the PVARP after PVC feature.

A Refractory - same chamber

Dual-chamber Modes

Atrial Refractory provides an interval following an atrial paced or sensed event when additional atrial sensed events do not impact the timing of pacing delivery.

The following are nonprogrammable intervals for dual-chamber modes:

- 85 ms Atrial Refractory following an atrial sensed event
- 150 ms Atrial Refractory following an atrial pace in DDD(R) and DDI(R) modes

RV-Refractory (RVRP)

The programmable RVRP provides an interval following an RV pace event, or leading ventricular pace event when LV Offset is not programmed to zero, during which RV sensed events do not impact the timing of pacing delivery.

Additionally, a 135 ms nonprogrammable refractory period provides an interval following an RV sensed event during which further RV sensed events do not impact the timing of pacing delivery.

Any event which falls into VRP is not detected or marked (unless it occurs within the noise window), and does not impact timing cycles.

RVRP is available in any mode where ventricular sensing is enabled, and RVRP can be programmed to a fixed or dynamic interval (Figure 4-44 Relationship between ventricular rate and refractory interval on page 4-69):

- Fixed—RVRP remains at the programmed, fixed RVRP value between the LRL and the applicable upper rate limit (MPR, MTR or MSR).
- Dynamic—RVRP shortens as ventricular pacing increases from the LRL to the applicable upper rate limit, allowing adequate time for RV sensing.
 - Maximum—if the pacing rate is less than or equal to the LRL (i.e., hysteresis), the programmed Maximum VRP is used as the RVRP.
 - Minimum—if the pacing rate is equal to the applicable upper rate limit, the programmed Minimum VRP is used as the RVRP.

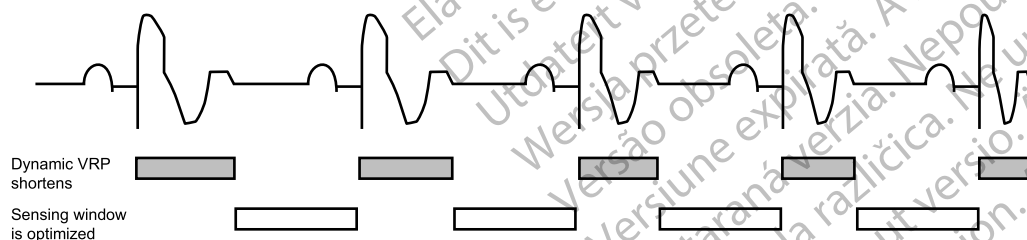

Figure 4-44. Relationship between ventricular rate and refractory interval

To provide an adequate sensing window, the following Refractory value (fixed or dynamic) programming is recommended:

- Single-chamber modes—less than or equal to one-half the LRL in ms
- Dual-chamber modes—less than or equal to one-half the applicable upper rate limit in ms

The use of a long RVRP shortens the ventricular sensing window.

Programming the Ventricular Refractory Period to a value greater than PVARP can lead to competitive pacing. For example, if the Ventricular Refractory is longer than PVARP, an atrial event can be appropriately sensed following PVARP and intrinsic conduction to the ventricle falls into the Ventricular Refractory Period. In this case, the device will not sense the ventricular depolarization and will pace at the end of the AV Delay, resulting in competitive pacing.

LV-Refractory (LVRP)

The LVRP prevents sensed electrical events from causing an inappropriate loss of CRT following a sensed or paced event, such as a left-sided T-wave. Proper programming of this feature will help maximize CRT delivery while reducing the risk of accelerating the patient's rhythm to a ventricular tachyarrhythmia.

CRT should be delivered continuously to maximize the patient benefit; however, there are circumstances when it may be appropriate to inhibit therapy delivery. LVRP provides an interval following an LV sense or pace event, or leading ventricular pace event when LV Offset is not programmed to zero, during which LV sensed events do not impact the timing of therapy delivery. Use of a long LVRP shortens the LV sensing window.

LVRP is available in any mode where LV sensing is enabled. The LV interval remains at the programmed fixed value between the LRL and the applicable upper rate limit.

LV oversensing of a T-wave may inhibit LV pacing. To prevent inappropriate inhibition of LV pacing, program LVRP to a duration sufficiently long to include the T-wave.

Left Ventricular Protection Period (LVPP)

The LVPP prevents the pulse generator from inadvertently delivering a pacing stimulus during the LV vulnerable period if, for example, a left-sided PVC occurs. Proper programming of this feature will help maximize CRT delivery while reducing the risk of accelerating the patient's rhythm to a ventricular tachyarrhythmia.

CRT should be delivered continuously to maximize the patient benefit; however, there are circumstances when it may be appropriate to inhibit therapy delivery. LVPP is the period after a paced or sensed LV event when the pulse generator will not pace the left ventricle. LVPP prevents the pulse generator from pacing into the LV vulnerable period.

CAUTION: Use of a long LVPP reduces the maximum LV pacing rate and may inhibit CRT at higher pacing rates.

NOTE: *If LVPP inhibits in LV Only, the pulse generator will issue an RV pace for bradycardia support.*

LVPP is available in any mode where ventricular sensing and LV pacing are enabled.

Cross-Chamber Blanking

This feature is available in AUTOGEN, DYNAGEN, INOGEN, ORIGEN, INCEPTA, ENERGEN, PUNCTUA, and COGNIS devices.

Cross-chamber blanking periods are designed to promote appropriate sensing of in-chamber events and prevent oversensing of activity in another chamber (e.g., cross-talk, far-field sensing).

Cross-chamber blanking periods are initiated by paced and/or sensed events in an adjacent chamber. For example, a blanking period is initiated in the right ventricle each time a pacing pulse is delivered to the right atrium; this prevents the device from detecting the atrial paced event in the right ventricle.

Cross-chamber Blanking can be programmed to Smart or a fixed value. Smart Blanking is designed to promote appropriate sensing of in-chamber events by shortening the cross-chamber blanking period (37.5 ms following paced events and 15 ms following sensed events) and prevent oversensing of cross-chamber events by automatically raising the AGC threshold for sensing at the expiration of the Smart Blanking period.

Smart Blanking does not change the programmed AGC Sensitivity settings.

NOTE: *Smart Blanking periods will be lengthened to 85 ms if a same-chamber blanking period or a retriggerable noise window is active when the Smart Blanking period begins. For example, if an RV sense occurs within the atrial refractory period, the A-Blank after RV-Sense cross chamber blank will be 85 ms.*

CAUTION: Sensitivity adjustments associated with Smart Blanking may not be sufficient to inhibit detection of cross-chamber artifacts if the cross-chamber artifacts are too large. Consider other factors that impact the size/amplitude of cross-chamber artifacts including lead-placement, pacing output, programmed Sensitivity settings, shock output, and time since last delivered shock.

RV-Blank after A-Pace

RV-Blank after A-Pace is a cross-chamber blanking period designed to promote the appropriate sensing of RV events and prevent oversensing of cross-chamber events following an atrial pace.

If RV-Blank after A-Pace is programmed to a fixed period, the pulse generator will disregard RV events for the duration selected following an atrial pace. If a fixed period is chosen, then there is the increased potential for undersensing of R-waves (e.g., PVCs) in the cross-chamber blanking period after atrial pacing.

If the value is programmed to Smart, the pulse generator automatically raises the AGC threshold for sensing at the expiration of the Smart Blanking period in order to aid rejection of cross-chamber atrial events. This promotes sensing of R-waves that may have otherwise fallen into the cross-chamber Blanking period. Smart Blanking does not change the programmed Sensitivity settings.

Smart Blanking is designed to promote sensing of R-waves, and should only be considered when PVCs occur during the cross-chamber blanking period following an atrial pace and are not properly sensed.

When Smart Blanking is used, it is possible that polarization artifacts following atrial pacing may be detected as R-waves. These artifacts are likely a result of voltage build-up on the ventricular sensing lead following tachy therapy or high-output ventricular pacing, and may inhibit ventricular pacing.

When adjusting Blanking, consider the following:

- If the patient is pacemaker-dependent, test for proper sensing after shock therapy. If oversensing is occurring post-shock, be prepared to use the STAT PACE command.
- To promote continuous pacing for pacemaker-dependent patients, it may be preferable to lessen the potential for ventricular oversensing of atrial paced artifacts by programming a longer blanking period. However, programming a longer blanking period may increase the likelihood of undersensing R-waves (e.g., PVCs, should they occur within the RV-Blank after A-Pace cross-chamber blanking period).
- For patients with a high percentage of atrial pacing and frequent PVCs who are not pacemaker-dependent, it may be preferable to shorten the blanking period to lessen the potential for undersensing a PVC (should it occur in the cross-chamber blanking period).

following an atrial paced event). However, a shorter blanking period may increase the likelihood for ventricular oversensing of an atrial paced event.

LV-Blank after A-Pace

LV-Blank after A-Pace is a cross-chamber blanking period designed to promote the appropriate sensing of LV events and prevent oversensing of cross-chamber events following an atrial pace. The pulse generator will not respond to LV events for the duration selected following an atrial pace.

If the value is programmed to Smart, the pulse generator automatically raises the AGC threshold for sensing at the expiration of the Smart Blanking period in order to aid rejection of cross-chamber atrial events. This promotes sensing of LV events that may have otherwise fallen in the cross-chamber blanking period. Smart Blanking does not change the programmed Sensitivity settings.

A-Blank after V-Pace

A-Blank after V-Pace is a cross-chamber blanking period designed to promote the appropriate sensing of P-waves and prevent oversensing of cross-chamber events following either an RV or LV pace.

If the value is programmed to Smart, the pulse generator automatically raises the AGC threshold for sensing at the expiration of the Smart Blanking period in order to aid rejection of cross-chamber ventricular events. This promotes sensing of P-waves that may have otherwise fallen in the cross-chamber blanking period. Smart Blanking does not change the programmed Sensitivity settings.

A-Blank after RV-Sense

A-Blank after RV-Sense is a cross-chamber blanking period designed to promote appropriate sensing of P-waves and prevent oversensing of cross-chamber events following an RV-sensed event.

If the value is programmed to Smart, the pulse generator automatically raises the AGC threshold for sensing at the expiration of the Smart Blanking period in order to aid rejection of cross-chamber RV events. This promotes sensing of P-waves that may have otherwise fallen in the cross-chamber blanking period. Smart Blanking does not change the programmed Sensitivity settings.

Refer to the following illustrations:

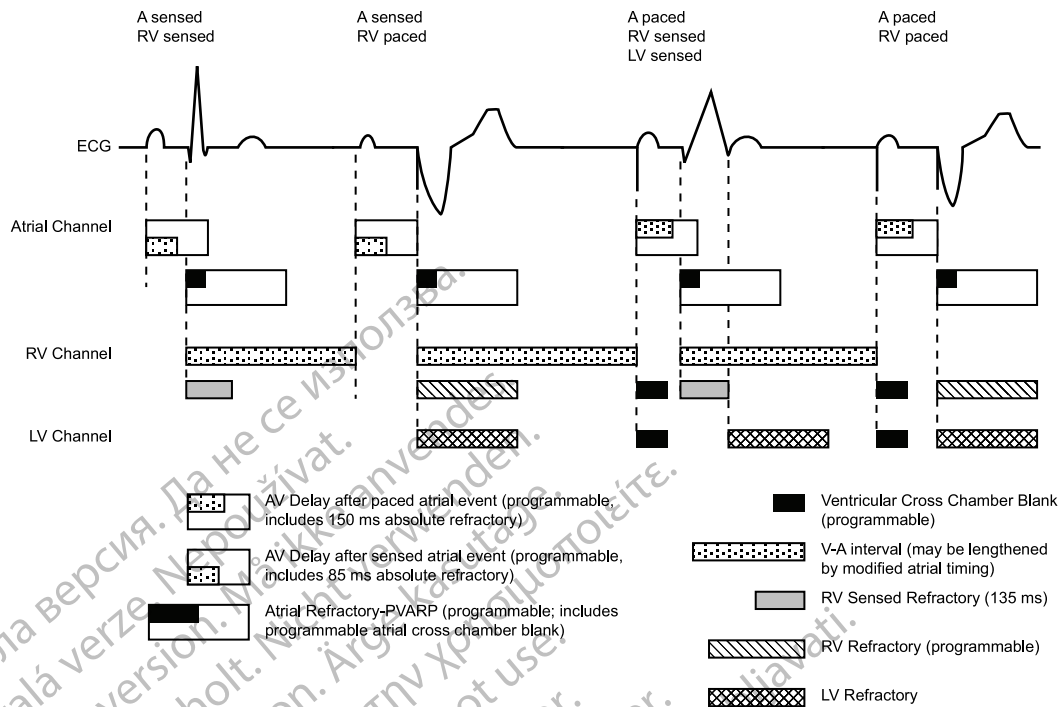

Figure 4-45. Refractory periods, dual-chamber pacing modes; RV only

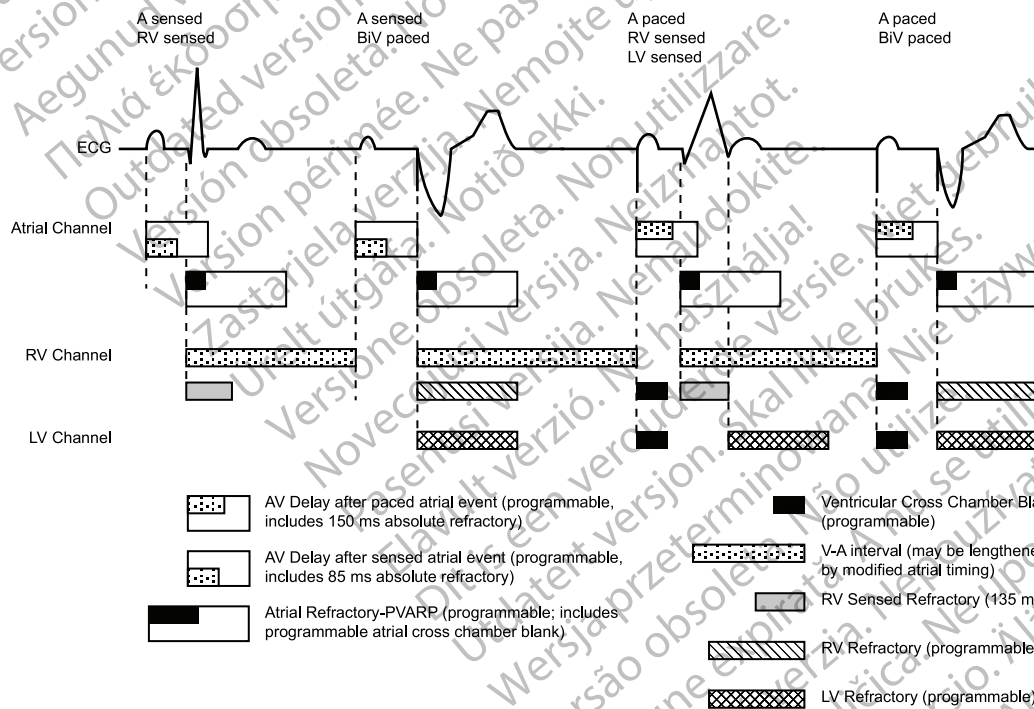

Figure 4-46. Refractory periods, dual-chamber pacing modes; BiV

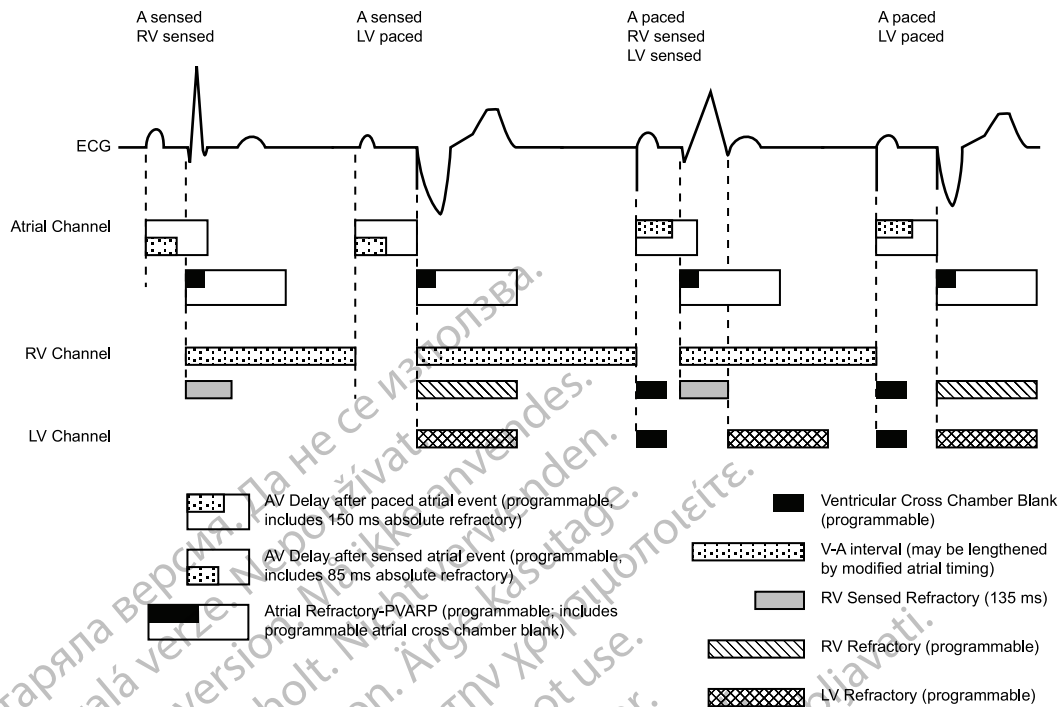

Figure 4-47. Refractory periods, dual-chamber pacing modes; LV only

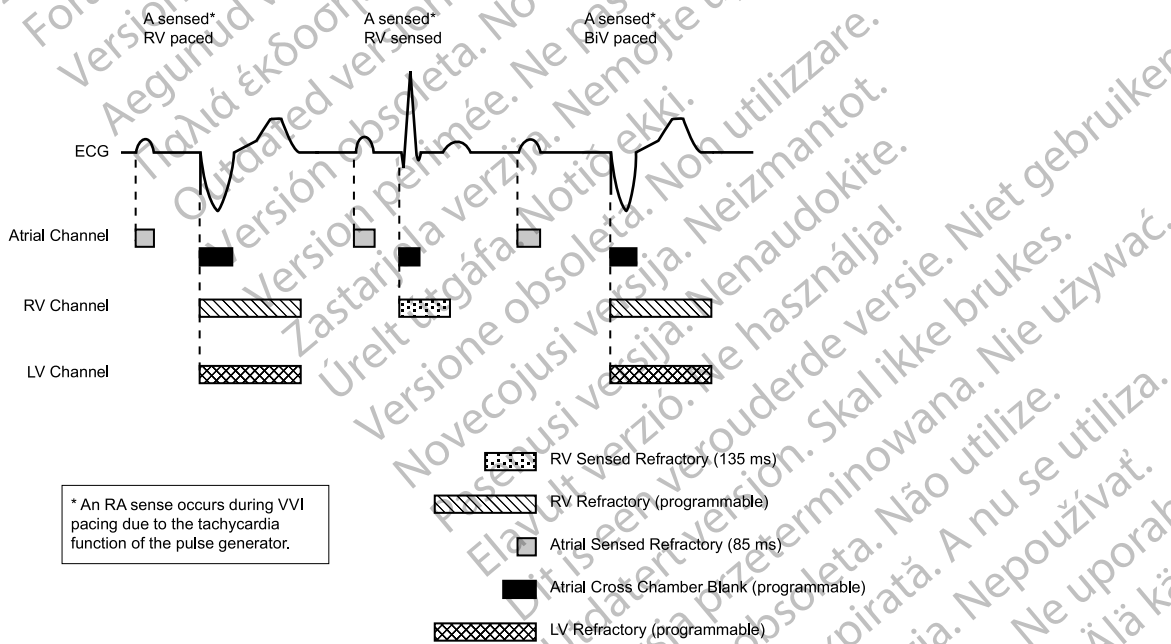

Figure 4-48. Refractory periods, VVI pacing mode; RV and BiV

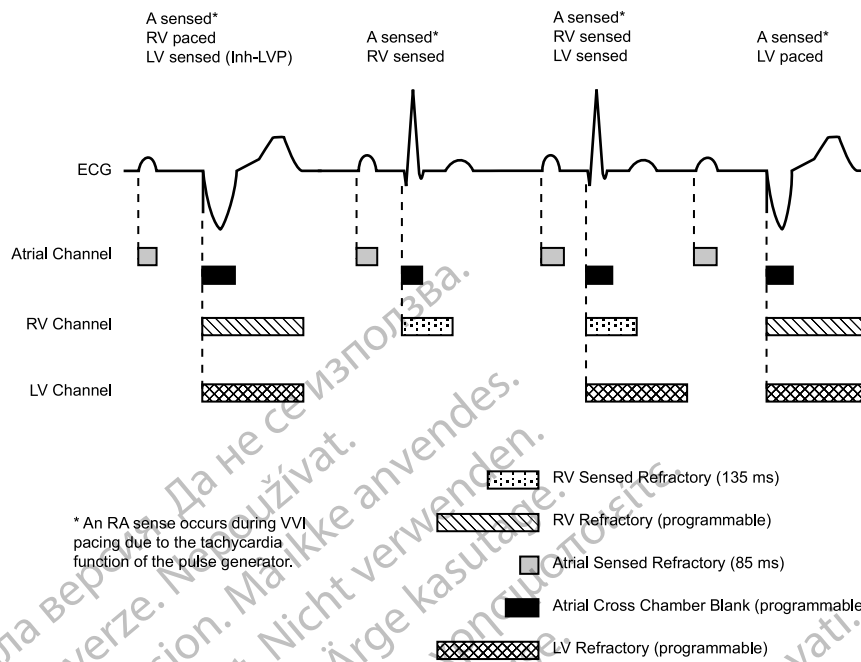

Figure 4-49. Refractory periods, VVI pacing mode; LV only

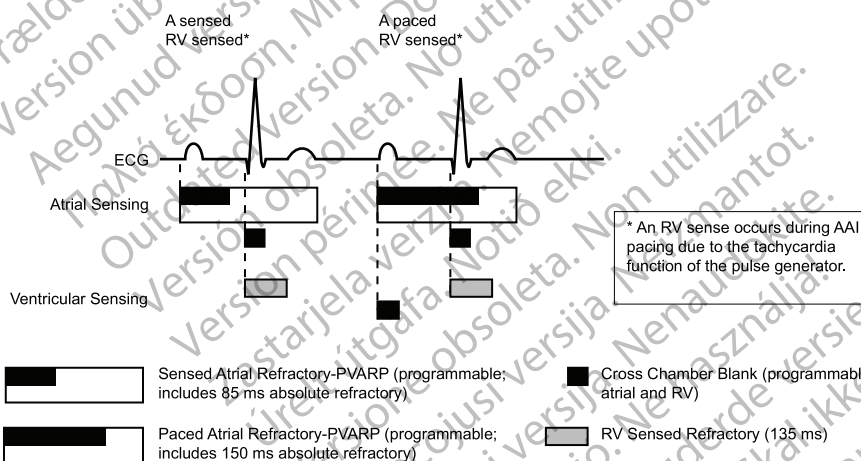

Figure 4-50. Refractory periods, AAI pacing mode; DR

NOISE RESPONSE

This feature is available in AUTOGEN, DYNAGEN, INOGEN, ORIGEN, INCEPTA, ENERGEN, PUNCTUA, and COGNIS devices.

Noise windows and blanking periods are designed to prevent inappropriate therapy or pacing inhibition due to cross-chamber oversensing.

Noise Response allows the clinician to choose whether to pace or inhibit pacing in the presence of noise.

A retriggerable, 40-ms noise window exists within each refractory and fixed (non-smart) cross-chamber blanking period. The window is initiated by either a sensed or paced event. Both the noise window and the refractory period must be completed for each cardiac cycle in one chamber before the next event restarts the timing in the same chamber. Recurrent noise activity may cause the noise window to restart, extending the noise window and possibly the effective refractory period or blanking period.

The Noise Response parameter can be programmed to Inhibit Pacing or an asynchronous mode. The available asynchronous mode will automatically correspond to the permanent Brady Mode (i. e., VVI permanent mode will have VOO noise response). If Noise Response is programmed to an asynchronous mode and the noise persists so that the noise window is extended longer than the programmed pacing interval, the pulse generator paces asynchronously at the programmed pacing rate until the noise ceases. If Noise Response is programmed to Inhibit Pacing and persistent noise occurs, the pulse generator will not pace in the noisy chamber until after the noise ceases. The Inhibit Pacing mode is intended for patients whose arrhythmias may be triggered by asynchronous pacing.

Refer to the following illustrations.

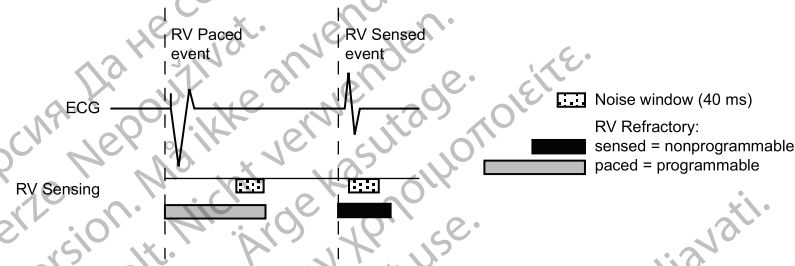

Figure 4-51. Refractory periods and noise windows, RV

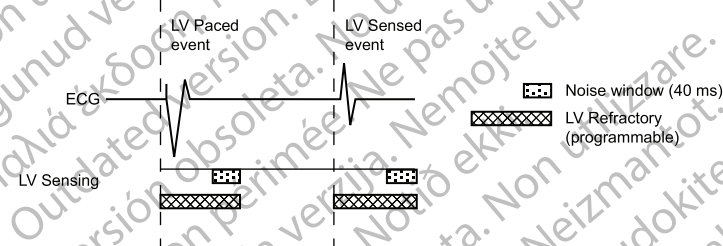

Figure 4-52. Refractory periods and noise windows, LV

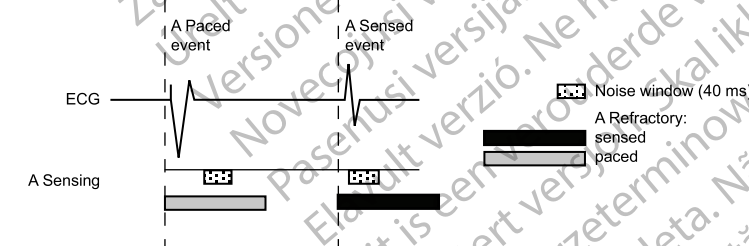

Figure 4-53. Refractory periods and noise windows, RA

In addition, a nonprogrammable Dynamic Noise Algorithm is active in all rate channels.

The Dynamic Noise Algorithm uses a separate noise channel to continuously measure the baseline signal and adjust the sensing floor to avoid noise detection. This algorithm is intended to help prevent oversensing of myopotential signals and the problems associated with oversensing.

If event markers are being transmitted, depending on the chamber where noise is occurring, the marker [AS], [RVS], or [LVS] occurs when the noise window is initially triggered following a pace. If the noise window is retriggered for 340 ms, the markers AN, RVN, or LVN occur. With continuous retriggers, the AN, RVN, or LVN markers will occur frequently. If asynchronous pacing occurs due to continuous noise, the markers AP-Ns, RVP-Ns, or LVP-Ns will occur.

NOTE: In pacer-dependent patients, use care when considering setting Noise Response to Inhibit Pacing as pacing will not occur in the presence of noise.

NOTE: If noise inhibits in LV Only, the device will issue an RV pace for bradycardia support provided there is no noise in the RV channel.

Noise Response example

Cross-chamber sensing that occurs early in the AV Delay may be detected by the RV sense amplifiers during the fixed blanking period, but is not responded to except to extend the noise rejection interval. The 40 ms noise rejection interval continues to retrigger until the noise is no longer detected, up to the length of the AV Delay. If noise continues throughout the duration of the AV Delay, the device will deliver a pacing pulse when the AV Delay timer expires, preventing ventricular inhibition due to noise. If a ventricular pacing spike is delivered under conditions of continuous noise, a VP-Ns marker notation appears on the intracardiac electrogram (Figure 4–54 Noise Response (fixed blanking) on page 4-77).

If noise ceases prior to the expiration of the AV Delay, the device can detect an intrinsic beat that occurs at any time beyond the 40 ms retriggerable noise interval and initiate a new cardiac cycle.

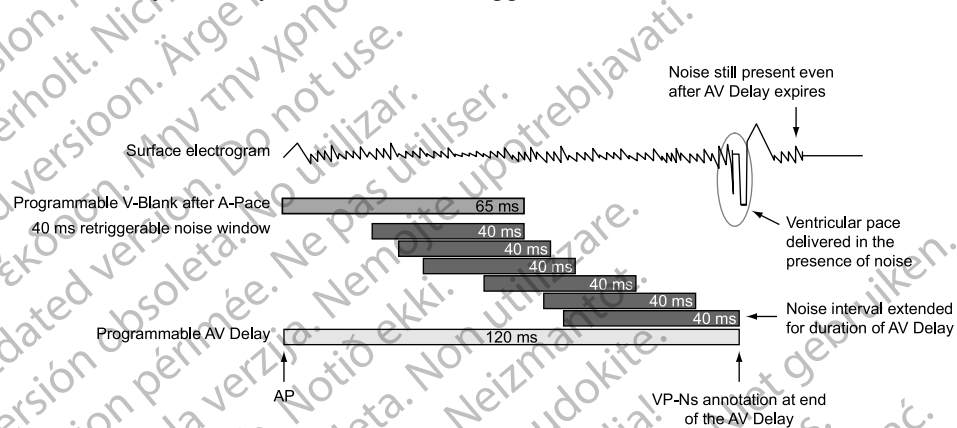

Figure 4–54. Noise Response (fixed blanking)

VENTRICULAR TACHY SENSING INTERACTIONS

Refractory periods and blanking intervals are an integral part of the pulse generator sensing system. They are used to efficiently suppress detection of pulse generator artifacts (e.g., a pace or shock) and certain intrinsic signal artifacts (e.g., a T-wave or far-field R-wave). The pulse generator does not discriminate between events that occur during Refractory periods and blanking intervals. As a result, all events (pulse generator artifacts, intrinsic artifacts, and intrinsic events) that occur during a refractory period or blanking interval are ignored for purposes of pacing timing cycles and Ventricular Tachy Detection.

Certain programmed combinations of pacing parameters are known to interfere with ventricular tachy detection. When an intrinsic beat from a VT occurs during a pulse generator refractory period, the VT beat will not be detected. As a result, detection and therapy of the arrhythmia may be delayed until enough VT beats are detected to satisfy the tachy detection criteria ("Ventricular Detection Windows" on page 2-12).

Pacing Parameter Combination Examples

The following examples illustrate the effects of certain pacing parameter combinations on ventricular sensing. When programming pulse generator pacing and tachy detection parameters, consider the possible interactions of these features in light of the expected arrhythmias. In general, the PRM screen displays Parameter Interaction Attentions and advisory messages to inform you about programming combinations that could interact to cause these scenarios; the

interactions can be resolved by reprogramming the pacing Rate, AV Delay and/or refractory/blanking periods.

Example 1: Ventricular Undersensing Due to Ventricular Refractory Period

If the pulse generator is programmed as follows, a VT that occurs synchronous with the pacing will not be detected:

- Brady Mode = VVI
- LRL = 75 min⁻¹ (800 ms)
- VRP = 500 ms
- VT Zone = 150 min⁻¹ (400 ms)

In this scenario, the pulse generator is VVI pacing at LRL (800 ms). A 500 ms VRP follows each ventricular pace. VT beats that occur during VRP are ignored for purposes of pacemaker timing and Ventricular Tachy Detection/Therapy. If a stable VT of 400 ms starts simultaneously with a ventricular pace, the VT will not be detected because every beat will occur during the 500 ms VRP, either concurrent with a ventricular pace or 400 ms after a pace (Figure 4–55 Ventricular undersensing due to VRP on page 4-78).

NOTE: It is not required for the VT to start concurrently with a pace for undersensing to occur. In this example, all pacing will be inhibited and tachy detection will subsequently occur, as soon as a single VT beat is detected.

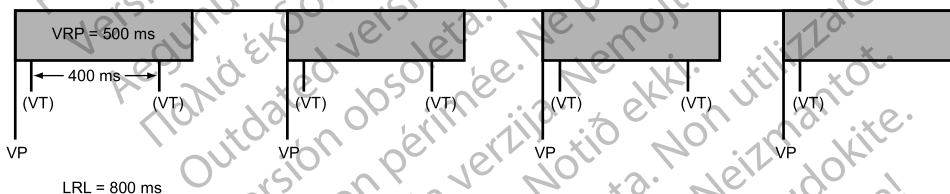

Figure 4–55. Ventricular undersensing due to VRP

When the programming interaction described in this scenario is present, a message will describe the interaction of VRP with LRL. In rate-responsive or tracking modes (e.g., DDDR), similar messages may describe the interaction of VRP with MTR, MSR, or MPR. Along with each message, the pertinent programmable parameters are displayed to assist in resolving the interaction. Programming Dynamic VRP can be useful in resolving these types of interactions.

Example 2: Ventricular Undersensing Due To V-Blank After A-Pace

Certain programmed combinations of dual-chamber pacing parameters may also interfere with Ventricular Tachy Detection. When dual-chamber pacing occurs, pulse generator refractory periods are initiated by both atrial and ventricular paces. The ventricular refractory period following a ventricular pace is controlled by the VRP parameter; the ventricular refractory period following an atrial pace is controlled by the V-Blank After A-Pace parameter.

Undersensing of a VT due to the pulse generator refractory periods may occur when the pulse generator is pacing at or above LRL. For example, if the pulse generator is rate-adaptive pacing at 100 min⁻¹ (600 ms) and is programmed as follows, then a VT that occurs synchronous with the pacing may not be detected:

- LRL = 90 min⁻¹ (667 ms), MTR/MSR = 130 min⁻¹ (460 ms)
- Brady Mode = DDDR, Fixed AV delay = 300 ms
- VRP = 230 ms
- V-Blank After A-Pace = 65 ms

- VT Zone = 150 min⁻¹ (400 ms)

In this scenario, the pulse generator is DDDR pacing at 600 ms. A VRP of 230 ms follows each ventricular pace; a Ventricular Refractory Period of 65 ms (V-Blank after A-Pace) follows each atrial pace; an atrial pace occurs 300 ms after each ventricular pace. VT beats that occur during either refractory period are ignored for purposes of pacemaker timing and Ventricular Tachy Detection/Therapy. If a stable VT of 350 ms starts, then the VT will not be detected because most beats will occur during a ventricular refractory period, either V-Blank after A-Pace or VRP. Some VT beats will be detected, but not enough to satisfy the 8 of 10 tachy detection criteria ("Ventricular Detection Windows" on page 2-12).

NOTE: It is not required for the VT to start concurrently with a refractory period or blanking interval for undersensing to occur. In this example, it is likely that the VT will not be detected until either the VT accelerates to faster than 350 ms or the sensor-driven pacing rate changes from 600 ms.

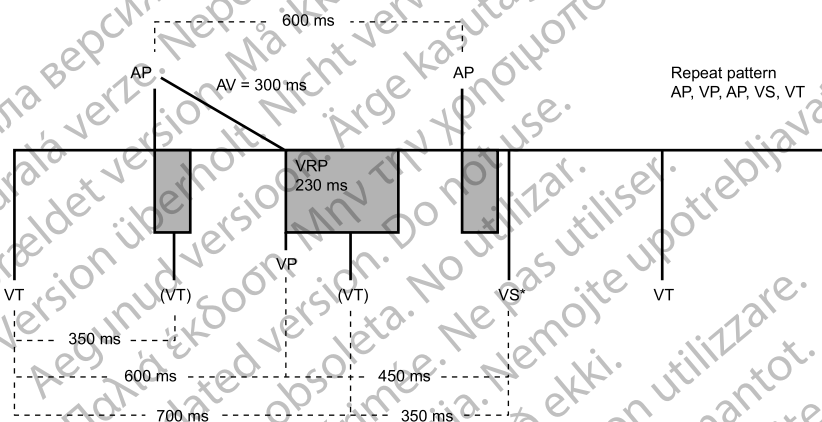

Figure 4-56. Ventricular undersensing due to V-Blank after A-Pace

When the programming interaction described in this scenario is present, a message will describe the interaction of Tachy Rate Threshold with LRL and AV Delay. Similar messages may describe the interaction of V-Blank after A-Pace with MTR, MPR, or LRL. Along with each message, the pertinent programmable parameters are displayed to assist you in resolving the interaction. Programming Dynamic VRP can be useful in resolving these types of interactions.

Programming Considerations

Certain programmed combinations of pacing parameters are known to interfere with Ventricular Tachy Detection. The risk of ventricular tachy undersensing due to device refractory periods is indicated by the interactive warnings on the parameter screen.

As with all device programming, you should evaluate the benefits and the risks of the programmed features for each patient (for example, the benefit of Rate Smoothing with a long AV Delay versus the risk of ventricular tachy undersensing).

The following programming recommendations are provided to reduce the risk of ventricular undersensing due to the refractory period caused by an atrial pace (V-Blank after A-Pace):

- If a dual-chamber pacing mode with Rate Smoothing or Rate Adaptive Pacing is necessary:
 - Reduce the LRL
 - Shorten the AV Delay or use Dynamic AV Delay and reduce the minimum Dynamic AV Delay setting

- Increase the Down Rate Smoothing percentage to the largest possible value
- Decrease the Recovery Time for Rate Adaptive Pacing modes
- Reduce the MTR or MPR if Down Rate Smoothing is on
- Reduce the MSR if the pacing mode is rate adaptive
- If Rate Smoothing or Rate Adaptive Pacing are not required for the patient, consider programming these features Off. Programming these features Off can reduce the likelihood of atrial pacing at elevated rates.
- If atrial pacing is not required for the patient, consider using VDD rather than DDD pacing mode.
- In certain usage scenarios, you may elect to program long AV Delays to reduce ventricular pacing for patients with long PR intervals, while providing sensor pacing or Rate Smoothing to address other patient needs.
- In certain usage scenarios, if a pattern of atrial pacing and VT beats is detected, the Brady Tachy Response (BTR) feature will automatically adjust the AV Delay to facilitate confirmation of a suspected VT. If no VT is present, the AV Delay is returned to the programmed value. For programming scenarios where the automatic AV Delay adjustment may occur, a specific Parameter Interaction Attention will not be displayed.

For discussion of details and additional information regarding these or other programmed settings, please contact Boston Scientific using the information on the back cover.

In summary, when programming the pulse generator pacing and tachy detection parameters, it is useful to consider the possible interactions of these features in light of the expected arrhythmias of a particular patient. In general, the interactions will be brought to your attention through Parameter Interaction Attention messages on the PRM screen and can be resolved by reprogramming the pacing Rate, AV Delay, and/or refractory/blanking periods.

SYSTEM DIAGNOSTICS

CHAPTER 5

This chapter contains the following topics:

- “Summary Dialog” on page 5-2
- “Battery Status” on page 5-2
- “Leads Status” on page 5-7
- “Lead Tests” on page 5-11

SUMMARY DIALOG

Upon interrogation, a Summary dialog is displayed. It includes Leads and Battery status indications, approximate time to explant, and an Events notification for any episodes since the last reset. In addition, a magnet notification will appear if the pulse generator detects the presence of a magnet.

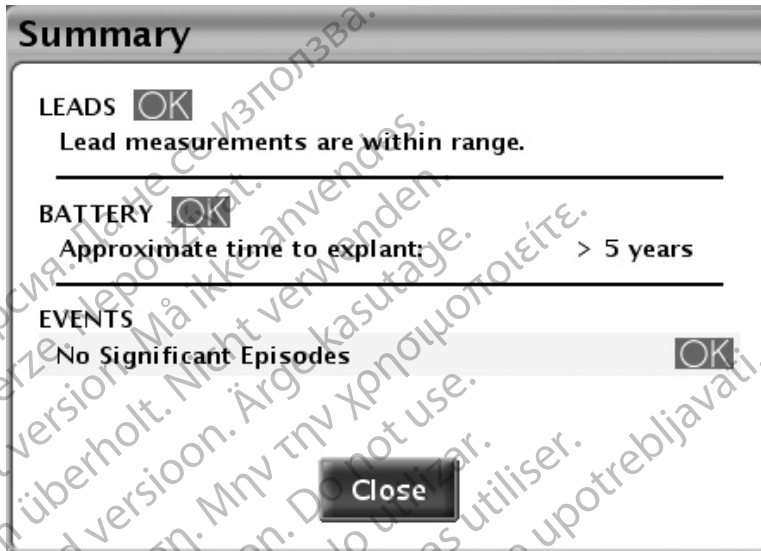

Figure 5-1. Summary dialog

Potential status symbols include OK, Attention, or Warning ("Use of Color" on page 1-7). Potential messages are described in the following sections:

- Leads—"Leads Status" on page 5-7
- Battery—"Battery Status" on page 5-2
- Events—"Therapy History" on page 6-2

Once the Close button is selected, the Warning or Attention symbols for Leads and Battery will not appear on subsequent interrogations until additional events triggering an alert condition occur. Events will continue to appear until any history counter Reset button is selected.

BATTERY STATUS

The pulse generator automatically monitors battery capacity and performance. Battery status information is provided via several screens:

- Summary dialog—displays a basic status message about remaining battery capacity ("Summary Dialog" on page 5-2).
- Summary tab (on the Main Screen)—displays the same basic status message as the Summary dialog, along with the battery status gauge ("Main Screen" on page 1-2).
- Battery Status Summary screen (accessed from the Summary tab)—displays additional battery status information about remaining battery capacity and Charge Time ("Battery Status Summary Screen" on page 5-3).
- Battery Detail screen (accessed from the Battery Status Summary screen)—provides detailed information about battery use, capacity, and performance ("Battery Detail Summary Screen" on page 5-5).

Battery Status Summary Screen

The Battery Status Summary screen provides the following key information about battery capacity and performance.

Time Remaining

This section of the screen displays the following items:

- Battery status gauge—displays a visual indication of the time remaining to explant.
- Approximate time to explant—displays the estimate of calendar time remaining until the pulse generator reaches the Explant status.

This estimate is calculated using battery capacity consumed, charge remaining, and power consumption at current programmed settings.

When insufficient usage history is available, Approximate time to explant may change between interrogation sessions. This fluctuation is normal, and occurs as the pulse generator collects new data and can calculate a more stable prediction. Approximate time to explant will be more stable after several weeks of usage. Causes of fluctuation may include the following:

- If certain brady features that affect pacing output are reprogrammed, the Approximate time to explant will be forecasted based on the expected changes in power consumption from the reprogrammed features. The next time the pulse generator is interrogated, the PRM will resume displaying Approximate time to explant based on recent usage history. As new data is collected, Approximate time to explant will likely stabilize near the initial forecast.
- For several days post-implant, the PRM will display a static Approximate time to explant based on model-dependent data. Once enough usage data has been collected, device-specific predictions will be calculated and displayed.

Charge Time

This section of the screen displays the amount of time it took the pulse generator to charge for the most recent maximum-energy shock or capacitor re-formation.

Battery Detail icon

When selected, this icon displays the Battery Detail Summary screen ("Battery Detail Summary Screen" on page 5-5).

Battery Status Indicators

The following battery status indicators appear in the battery status gauge. The indicated Approximate time to explant is calculated based on the pulse generator's current programmed parameters.

One Year Remaining—approximately one year of full pulse generator function remains (Approximate time to explant is one year).

Explant—the battery is nearing depletion, and pulse generator replacement must be scheduled. Once Explant status is reached there is sufficient battery capacity to monitor and pace 100% under existing conditions for three months and to deliver three maximum-energy shocks, or to deliver six maximum energy shocks with no pacing. When Explant status is reached, 1.5 hours of ZIP telemetry remain. Consider using wanded telemetry.

NOTE: When the 1.5 hours of telemetry are exhausted, a LATITUDE alert is generated.

Battery Capacity Depleted—pulse generator functionality is limited, and therapies can no longer be guaranteed. This status is reached three months after Explant status is reached. The patient should be scheduled for immediate device replacement. Upon interrogation, the Limited Device Functionality screen is displayed (all other screens are disabled). This screen provides battery status information and access to remaining device functionality. ZIP telemetry is no longer available.

NOTE: A LATITUDE alert is generated, after which LATITUDE NXT ceases interrogations of the device.

When the device reaches Battery Capacity Depleted status, functionality is limited to the following:

- Brady Mode will be changed as described below:

Brady Mode prior to Battery Capacity Depleted Indicator	Brady Mode after Battery Capacity Depleted Indicator
DDD(R), DDI(R), VDD(R), VVI(R)	VVI/BIV
AAI(R)	AAI ^a
Off	Off

a. COGNIS devices will change to VVI/BIV when the Brady Mode is AAI(R) prior to the Battery Capacity Depleted Indicator.

- Brady Mode and Ventricular Tachy Mode can be programmed to Off; no other parameters are programmable
- One ventricular zone (VF) with a rate threshold of 165 min⁻¹
- Wanded telemetry only (RF telemetry is disabled)
- Maximum-energy shocks and manual capacitor reformations only (ATP therapy and low-energy shocks are disabled)
- An LRL of 50 min⁻¹

At Battery Capacity Depleted status, the following features are disabled:

- Daily Measurement trends
- Brady enhancements (e.g., rate response, Rate Smoothing)
- PaceSafe RV Automatic Threshold (the output is fixed at the current output value)
- PaceSafe RA Automatic Threshold (the output is fixed at the current output value)
- PaceSafe LV Automatic Threshold (the output is fixed at the current output value)
- Episode storage
- Diagnostic and EP Tests
- Real-time EGMs
- MV sensor
- Accelerometer

If the device reaches a point where insufficient battery capacity is available for continued operation, the device will revert to Storage Mode. In Storage Mode, no functionality is available.

WARNING: MRI scanning after Explant status has been reached may lead to premature battery depletion, a shortened device replacement window, or sudden loss of therapy. After performing an MRI scan on a device that has reached Explant status, verify pulse generator function and schedule device replacement.

NOTE: The device uses the programmed parameters and recent usage history to predict Approximate time to explant. Greater than normal battery usage may result in the subsequent day's Approximate time to explant to appear less than expected.

NOTE: As a backup method, Explant is declared when two consecutive charge times exceed 15 seconds each. If a Charge Time is greater than 15 seconds, the pulse generator schedules an automatic capacitor re-formation for one hour later. If the Charge Time during re-formation also exceeds 15 seconds, the battery status is changed to Explant.

Battery Detail Summary Screen

The Battery Detail summary screen provides the following information about pulse generator battery status (Figure 5-2 Battery Detail summary screen on page 5-6):

- Last Delivered Shock—date, Energy, Charge Time, and Shock Impedance data.
- Beep when Explant Is Indicated—if this feature is programmed to On, the pulse generator emits 16 beeping tones every six hours after it reaches the Explant indicator. The tone can then be programmed to Off. Even when this feature is programmed to Off, it is automatically reactivated when the Battery Capacity Depleted indicator is reached.
- **CAUTION:** Patients should be advised to contact their physician immediately if they hear tones coming from their device.
- Last Capacitor Re-form—date and Charge Time.
- Manual Re-form Capacitor—this feature is used to command a capacitor re-formation when needed.
- Charge Remaining (measured in ampere-hours)—the amount of charge remaining based on the pulse generator's programmed parameters until the battery is depleted.
- Power Consumption (measured in microwatts)—the average daily power being used by the pulse generator, based on currently programmed parameters. Power consumption is included in the calculations that determine Approximate time to explant and the needle position on the battery status gauge.
- Power Consumption Percentage—compares the power consumption at the pulse generator's currently programmed parameters with the power consumption of the standard parameters used to quote device longevity.

If any of the following parameters (which affect pacing output) are reprogrammed, the Power Consumption and Power Consumption Percentage values are adjusted accordingly:

- Amplitude
- Pulse Width
- Brady Mode
- LRL
- MSR
- PaceSafe

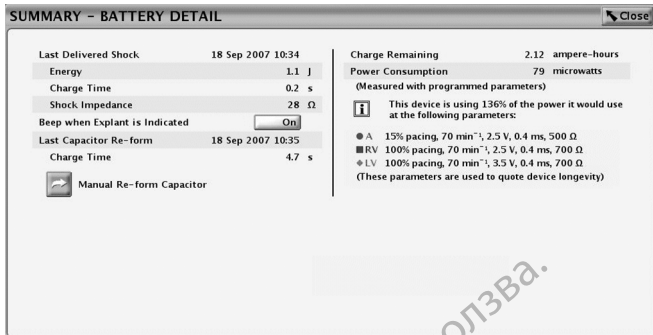

Figure 5-2. Battery Detail summary screen

Capacitor Re-formation

Automatic Capacitor Re-form. Capacitor deformation may occur during periods when no shocks are delivered, resulting in longer charge times. To reduce the effect of capacitor deformation on Charge Time, the capacitors are automatically re-formed. Tones will not be emitted from the pulse generator during automatic capacitor re-formations (even if the Beep During Capacitor Charge feature is programmed to On). During a capacitor re-formation, the Charge Time is measured and stored for later retrieval.

Manual Capacitor Re-form. Manual capacitor re-forms are not necessary, but may be commanded via the PRM as follows:

1. Select the Manual Re-form Capacitor button on the Battery Detail screen and ensure that telemetry communication is established. A message will appear indicating that the capacitors are charging. Warbling tones from the pulse generator (if the Beep During Capacitor Charge feature is programmed to On) will sound while the capacitors are charging.
2. The entire re-form cycle typically takes less than 15 seconds. After completion of the cycle, the capacitor energy is delivered to the pulse generator's internal test load. The initial Charge Time is displayed on the Battery Detail screen.

Charge Time Measurement

The pulse generator measures the Charge Time whenever its capacitors charge. The last measured value is stored in pulse generator memory and displayed by the PRM system on the Battery Detail screen.

Last Delivered Ventricular Shock

When a shock has been delivered to the patient, the following information from the last shock delivered is stored in the pulse generator's memory and displayed on the Battery Detail screen:

- Date
- Energy level
- Charge Time
- Shocking lead Impedance

This does not include auto capacitor re-forms or shocks that may have been diverted. If a fault condition is encountered (i.e., High or Low Impedance), the fault will be indicated so that corrective action may be taken.

NOTE: For shocks of 1.0 J or less, the accuracy of the impedance measurement decreases.

LEADS STATUS

Daily Measurements

The device performs the following measurements every 21 hours and reports them daily:

- Daily Intrinsic Amplitude measurement: the device will automatically attempt to measure the intrinsic P- and R- wave amplitudes for each cardiac chamber in which the Daily Intrinsic Amplitude measurement is enabled regardless of the pacing mode. This measurement will not affect normal pacing. The device will monitor up to 255 cardiac cycles to find a sensed signal to obtain a successful measurement.
- Daily lead (Pace Impedance) measurement:
 - Pace lead(s)—the device will automatically attempt to measure the pace lead impedance for each chamber in which the Daily Pace Impedance test is enabled, regardless of the pacing mode. To conduct the Lead Impedance Test the device utilizes a sub-pacing threshold signal that will not interfere with normal pacing or sensing.
 - The High Impedance Limit is nominally set to 2000 Ω , and is programmable in 250 Ω increments between 2000 Ω and either 3000 Ω (AUTOGEN, DYNAGEN, INOGEN, and ORIGEN devices) or 2500 Ω (INCEPTA, ENERGEN, PUNCTUA, and COGNIS devices). The Low Impedance Limit is nominally set to 200 Ω , and is programmable between 200 and 500 Ω in 50 Ω increments.

Consider the following factors when choosing a value for the Impedance Limits:

- For chronic leads, historical impedance measurements for the lead, as well as other electrical performance indicators such as stability over time
 - For newly implanted leads, the starting measured impedance value
- NOTE:** Depending on lead maturation effects, during follow-up testing the physician may choose to reprogram the Impedance Limits.
- Pacing dependence of the patient
 - Recommended impedance range for the lead(s) being used, if available
- Daily lead (Shock Impedance) measurement:
 - Shock lead—the device will automatically attempt to measure the shock lead impedance. During a shock Lead Impedance Test, the pulse generator delivers a subthreshold energy pulse through the shocking electrodes. These impedance measurements may show some variation over time, since they are taken every 21 hours and, thus, at different times of the day.
 - The Shock Low Impedance Limit is fixed at 20 Ω . The Shock High Impedance Limit is nominally set to 125 Ω , and is programmable between 125 and 200 Ω in 25 Ω increments. Consider the following factors when choosing a value for the High Impedance Limit:
 - For chronic leads, historical impedance measurements for the lead, as well as other electrical performance indicators such as stability over time
 - For newly implanted leads, the starting measured impedance value

NOTE: Depending on lead maturation effects, during follow-up testing the physician may choose to reprogram the High Impedance Limit.

- Recommended impedance range for the lead(s) being used, if available
- The impedance value of a high or maximum energy Shock Impedance test

NOTE: When a commanded or daily shock Lead Impedance Test result is above 125 Ω and the programmed Shock High Impedance Limit is greater than 125 Ω, confirm proper system operation by delivering a high-energy shock.

- The pulse generator contains a beeper that emits audible tones to communicate status information. The beeper includes a programmable feature that, when programmed On, will cause the pulse generator to emit tones when Daily Impedance values are out of range. The Beep When Out-of-Range indicator consists of 16 tones repeated every six hours. When this feature is programmed Off, there is no audible indication of out of range Daily Impedance values. Refer to "Beeper Feature" on page 6-22
- PaceSafe daily threshold measurements—when PaceSafe is programmed to Auto or Daily Trend, the device will automatically attempt to measure the pacing threshold in the chamber for which PaceSafe is programmed. To conduct the test, the device adjusts the necessary parameters to facilitate the test.

Basic lead status information is displayed on the Summary screen. Detailed data are displayed in a graphical format on the Leads Status summary screen, which can be accessed by selecting the leads icon on the Summary screen (Figure 5-3 Leads Status summary screen on page 5-9).

Possible leads status messages are as follows (Table 5-1 Lead measurement reporting on page 5-8):

- Lead measurements are within range.
- Check Lead (message will specify which lead)—indicates daily lead measurement(s) are out of range. To determine which measurement is out of range, evaluate the corresponding lead's daily measurement results.

NOTE: A detailed description of PaceSafe-specific messages including notification of lead test failures and lead alerts is available ("PaceSafe" on page 4-14).

Table 5-1. Lead measurement reporting

Lead Measurement	Reported Values	Out-of-Range Limits
A Pace Impedance (Ω)	200 to maximum programmable High Impedance Limit ^a	Low: ≤ programmed Atrial Low Impedance Limit High: ≥ programmed Atrial High Impedance Limit
RV Pace Impedance (Ω)	200 to maximum programmable High Impedance Limit ^a	Low: ≤ programmed Right Ventricular Low Impedance Limit High: ≥ programmed Right Ventricular High Impedance Limit
LV Pace Impedance (Ω)	200 to maximum programmable High Impedance Limit ^a	Low: ≤ programmed Left Ventricular Low Impedance Limit High: ≥ programmed Left Ventricular High Impedance Limit
Shock Impedance (Ω)	0 to 200	Low: ≤ 20 High: ≥ programmed Shock High Impedance Limit
P-Wave Amplitude (mV)	0.1 to 25.0	Low: ≤ 0.5 High: none

Table 5-1. Lead measurement reporting (continued)

Lead Measurement	Reported Values	Out-of-Range Limits
R-Wave (RV) Amplitude (mV)	0.1 to 25.0	Low: ≤ 3.0 High: none
R-Wave (LV) Amplitude (mV)	0.1 to 25.0	Low: ≤ 3.0 High: none

a. The maximum programmable High Impedance Limit is 2500 or 3000 Ω depending on the pulse generator model.

The Leads Status summary screen provides daily measurement details for applicable leads (Figure 5-3 Leads Status summary screen on page 5-9):

- The graph shows daily measurements from the past 52 weeks.
- Use the tabs across the top of the screen to view data for each lead. Select the Setup tab to enable or disable specific daily lead measurements or to set the Impedance Limit values.
- Each data point represents the daily measurement for a given day. To view specific results for a day, move the horizontal slider over the corresponding data point or gap.
- An out-of-range measurement will plot a point at the corresponding maximum or minimum value.
- A gap will be generated if the device is unable to obtain a valid measurement for that day.
- The most recent daily measurements are displayed at the bottom of the screen.

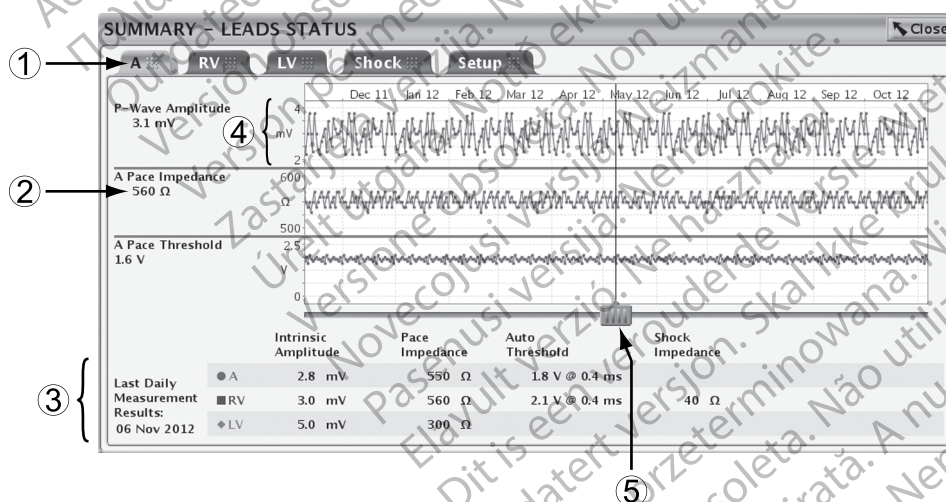

[1] Use tabs to select the appropriate lead [2] Results for the selected day [3] Results for most recent day [4] Y-axis adjusts based on measured results [5] Use horizontal slider to view data for a specific day

Figure 5-3. Leads Status summary screen

If the device is unable to obtain one or more daily measurements at the scheduled time, up to three re-attempts will be performed at one-hour intervals. Re-attempts do not change the timing of daily measurements. The next day's measurement will be scheduled 21 hours from the initial attempt.

If a valid measure is not recorded after the initial attempt plus three re-attempts, or is not recorded at the end of a 24-hour time block, the measurement will be reported as Invalid Data or No data collected (N/R).

Because eight measurements are recorded in seven days, one day will contain two measurements:

- For AUTOGEN, DYNAGEN, INOGEN, and ORIGEN devices, if one of the measurements is valid and one invalid for Amplitude and Impedance, the invalid measurement will be reported. If both measurements are valid, the most recent value will be reported. For Threshold, if one measurement is valid and one invalid, the valid measurement will be reported. If both measurements are valid, the highest value will be reported.
- For INCEPTA, ENERGEN, PUNCTUA, and COGNIS devices, if one measurement is valid and one invalid, the valid measurement will be reported. If both measurements are valid, the second value will be reported.

If the Summary screen indicates that a lead should be checked and the Intrinsic Amplitude and Impedance graphs do not show any out-of-range values or gaps, the test that resulted in the out-of-range value meets one of the following conditions:

- Test occurred within the current 24 hours and has not yet been saved with the daily measurements
- Test was the first measurement in a day when there were two measurements and the second value was not out of range (COGNIS devices)

Table 5-2. Intrinsic Amplitude: Daily Measurement Conditions, Programmer Display, and Graphical Representation

Condition	Programmer Display	Graphical Representation
In-range amplitude measurement	Measurement value	Plotted point
Electrode configuration is programmed to Off/None	No data collected	Gap
All events during the test period are paced	Paced	Gap
Noise detected during the test period	Noise	Gap
Sensed events defined as a PVC	PVC	Gap
Sensed events defined as a PAC	PAC	Gap
Out-of-range amplitude measurements (mV)	0.1, 0.2, ..., 0.5 (RA lead) with attention icon 0.1, 0.2, ..., 3.0 (ventricular lead) with attention icon	Plotted point
	< 0.1 with attention icon	Plotted point at corresponding minimum
	> 25 with attention icon	Plotted point at corresponding maximum ^a

a. When the value measured is > 25 mV, an attention symbol is displayed on the graph even though no alert is generated on the summary screens.

Table 5-3. Lead Impedance: Daily Measurement Conditions, Programmer Display, and Graphical Representation

Condition	Programmer Display	Graphical Representation
In-range impedance measurement	Measurement value	Plotted point
Electrode Configuration is programmed Off/None	Invalid Data	Gap
Noise detected during the test period	Noise	Gap
Out-of-range impedance measurements (pace leads) (Ω)	Measured value greater than or equal to the Pace High Impedance Limit with attention icon Measured value less than or equal to the Pace Low Impedance Limit with attention icon	Plotted point
	> Maximum Pace High Impedance Limit with attention icon < Minimum Pace Low Impedance Limit with attention icon	Plotted point at corresponding minimum or maximum ^a

Table 5-3. Lead Impedance: Daily Measurement Conditions, Programmer Display, and Graphical Representation (continued)

Condition	Programmer Display	Graphical Representation
Out-of-range impedance measurements (shock lead) (Ω)	Measured value greater than or equal to the programmed Shock High Impedance Limit (125–200) with attention icon 0; attention icon generated at ≤ 20	Plotted point
	> 200; attention icon generated	Plotted point at corresponding maximum ^b

- a. Selecting these points will not display the numerical value, but will indicate that the value is above the upper range limit or below the lower range limit, as appropriate.
- b. Selecting these points will not display the numerical value, but will indicate that the value is above the upper range limit.

Table 5-4. PaceSafe Automatic Threshold: Daily Measurement Conditions, Programmer Display, and Graphical Representation

Condition	Programmer Display	Graphical Representation
In-range threshold measurement	Measurement value	Plotted point
Feature is not enabled	No data collected	Gap
Test failures or out of range measurements	Various	Gap

NOTE: See a detailed list of failure codes for PaceSafe Threshold tests ("PaceSafe" on page 4-14).

Under the following conditions, Intrinsic Amplitude and Lead Impedance measurements will not be attempted. The programmer display will indicate No data collected or Invalid Data, and there will be a gap in the graphical representation:

- Tachy episode is in progress
- Tachy therapy is active
- Telemetry is active
- Post-Therapy parameters are in effect
- Device battery capacity is depleted
- LATITUDE interrogation is in progress
- Pulse generator is in Electrocautery Protection Mode
- Pulse generator is in MRI Protection Mode

See a detailed description of conditions under which PaceSafe measurements will not be attempted ("PaceSafe" on page 4-14).

LEAD TESTS

The following lead tests are available (Figure 5-4 Lead Tests screen on page 5-12):

- Pace Impedance
- Shock Impedance
- Intrinsic Amplitude
- Pace Threshold

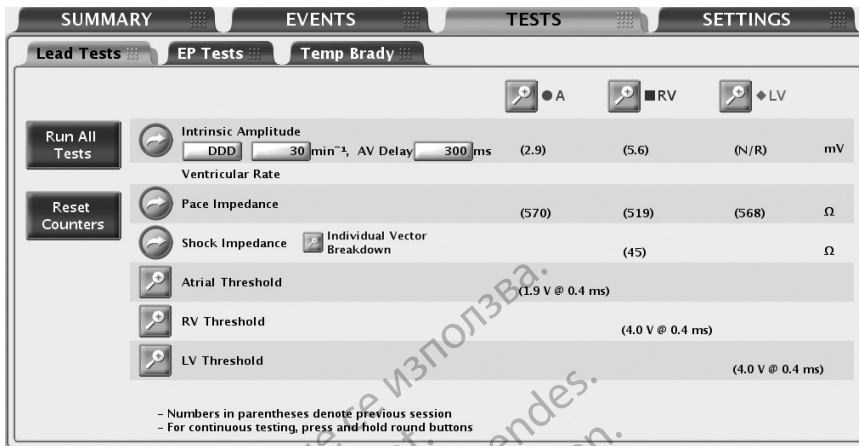

Figure 5-4. Lead Tests screen

Lead Tests can be accessed by using the following steps:

1. From the main screen, select the Tests tab.
2. From the Tests screen, select the Lead Tests tab.

All lead tests may be performed following three different processes:

- Via the Lead Tests screen—allows you to perform the same lead tests across all chambers
- By selecting the desired chamber button—allows you to perform all tests on the same lead
- By selecting the Run All Tests button—automatically performs Intrinsic Amplitude and Lead Impedance tests and allows you to perform Pace Threshold tests

Intrinsic Amplitude Test

The Intrinsic Amplitude Test measures the intrinsic P- and R-wave amplitudes for the respective chambers.

An Intrinsic Amplitude Test can be performed from the Lead Tests screen by completing the following steps:

1. You may change the following preselected values as necessary to elicit intrinsic activity in the chamber(s) being tested:
 - Programmed Normal Brady Mode
 - LRL at 30 min⁻¹
 - AV Delay at 300 ms

2. Select the Intrinsic Amplitude button. During the test, a window will display the test's progress. Selecting and holding the Intrinsic Amplitude Button will cause measurements to be repeated for up to 10 seconds or until the button is released. When the window closes, the same test can be performed again by selecting the Intrinsic Amplitude button. To cancel the test, select the Cancel button or press the DIVERT THERAPY key on the PRM.
3. When the test is complete, the Intrinsic Amplitude measurement will be displayed as the Current measurement (not in parentheses). If the test is repeated during the same session, the Current measurement will be updated with the new result. Note that the Previous Session measurement (displayed in parentheses) is from the most recent past session during which this test was performed.

NOTE: The test results from the last measurement are stored in pulse generator memory, retrieved during the initial interrogation, and displayed on the Lead Tests screen. The measurements are also provided on the Quick Notes report.

Lead Impedance Test

A Lead Impedance Test can be performed and used as a relative measure of lead integrity over time.

If the lead integrity is in question, standard lead troubleshooting tests should be used to assess the lead system integrity.

Troubleshooting tests include, but are not limited to, the following:

- Electrogram analysis with pocket manipulation and/or isometrics
- X-ray or fluoroscopic image review
- Additional maximum-energy shocks
- Programming the Shock Lead Vector
- Wireless ECG
- Invasive visual inspection

A Shock Impedance test is a useful tool in detecting shocking lead integrity changes over time. Evaluating this information together with the Last Delivered Shock Impedance (displayed on the Battery Detail screen) or a subsequent high-energy Shock Impedance and other non-invasive diagnostic techniques may help troubleshoot potential lead system conditions.

A test result of NOISE is reported if a valid measurement could not be obtained (likely due to EMI).

Shorted and open shock lead failures will be reported as 0 Ω and > 200 Ω , respectively.

NOTE: The Shock Impedance test may result in slightly higher values than delivered Shock Impedance measurements.

Both low-energy and high-energy impedance tests have the following clinical limitations:

- A high- or maximum-energy shock test does not expose all forms of open lead conditions. Shock lead impedance measured during a commanded maximum-energy shock may appear normal when certain types of open lead conditions exist (e.g., lead conductor fracture or a loose setscrew), as the energy delivered could jump or arc across small gaps. A commanded low-energy impedance test is a more robust tool for identifying and verifying a potential open shocking lead condition.
- A low-energy Lead Impedance Test does not expose all forms of shorted lead conditions. A low-energy impedance test may appear normal when certain types of shorted lead conditions exist (e.g., abraded lead body insulation or lead crushed between clavicle and first rib), as test energy is insufficient to jump or arc across small gaps between exposed conductors. A

maximum-energy shock is a more robust tool for identifying and verifying a potential shorted shocking lead condition.

Pace and Shock lead impedance tests can be performed from the Lead Tests screen by completing the following steps:

1. Select the desired lead impedance test button. Selecting and holding a button will cause measurements to be repeated for up to 10 seconds or until the button is released.
2. During the test, a window will display the test progress. When the window closes, the same test can be performed by once again selecting the desired lead impedance test button. To cancel the test, select the Cancel button or press the DIVERT THERAPY key on the PRM.
3. When the test is complete, the impedance measurement will be displayed as the Current measurement (not in parentheses). If the test is repeated during the same session, the Current measurement will be updated with the new result. Note that the Previous Session measurement (displayed in parentheses) is from the most recent past session during which this test was performed.
4. Select the Individual Vector Breakdown button to view additional out of range Shock Impedance test information (AUTOGEN, DYNAGEN, INOGEN, ORIGEN, INCEPTA, ENERGEN, and PUNCTUA devices). The Previous and Current Session results for individual shock vectors will be provided.
5. If the test results in NOISE, consider the following mitigation options:
 - Repeat the test
 - Switch telemetry modes
 - Remove other sources of electromagnetic interference

NOTE: The test results from the last measurement are stored in pulse generator memory, retrieved during the initial interrogation, and displayed on the Lead Tests screen. The measurements are also provided on the Quick Notes report.

Pace Threshold Test

The Pace Threshold Test determines the minimum output needed for capture in a specific chamber.

The ventricular and atrial pace amplitude threshold tests can be performed manually or automatically. When PaceSafe is programmed to Auto, the results of the commanded automatic amplitude tests may be used to adjust the PaceSafe output levels.

Ventricular and atrial pulse width threshold tests are performed manually by selecting the Pulse Width option on the Pace Threshold details screen.

Manual Pace Threshold Test

A minimum 2X voltage capture threshold or 3X pulse width capture threshold for each chamber is recommended to provide an adequate safety margin and help preserve battery longevity. The starting parameter values are automatically calculated prior to testing. The test begins at a specified starting value and steps that value down (Amplitude or Pulse Width) as the test progresses. The PRM beeps with each decrement. The values used during the threshold test are programmable. The parameters are only in effect during the test.

NOTE: If DDD mode is chosen, selecting either the atrial or ventricular test will cause the pacing output to decrease only in the chamber selected.

CAUTION: During manual LV Threshold and Quick Capture tests, RV Backup Pacing is unavailable.

NOTE: When a ventricular test is selected, only the pacing output of the selected ventricular chamber decreases; the other ventricular chamber is not paced.

Once the test is started, the device operates with the specified brady parameters. Using the programmed number of cycles per step, the device then decrements (steps down) the selected test type parameter (Amplitude or Pulse Width) until the test is complete. Real-time electrograms and annotated event markers, which include the LV pacing lead configuration and values being tested, continue to be available during threshold testing. The display will automatically adjust to reflect the chamber being tested.

During the threshold test, the programmer displays the test parameters in a window while the test is in progress. To pause the test or perform a manual adjustment, select the Hold button on the window. Select the + or - button to manually increase or decrease the value being tested. To continue the test, select the Continue button.

The threshold test is complete and all parameters are returned to the normal programmed values when any of the following occur:

- The test is terminated via a command from the PRM (e.g., pressing the End Test button or DIVERT THERAPY key).
- The lowest available setting for Amplitude or Pulse Width is reached and the programmed number of cycles has completed.
- Telemetry communication is interrupted.

A pace threshold test can be performed from the Lead Tests screen using the following steps:

1. Select the desired chamber to be tested.
2. Select the Pace Threshold details button.
3. Select the test type.
4. Change the following parameter values as desired to elicit pacing in the chamber(s) being tested:
 - Mode
 - LRL
 - Paced AV Delay
 - Pacing Lead Configuration (programmable only for LV Threshold test)
 - Amplitude
 - Pulse Width
 - Cycles per Step
 - LV Protection Period (programmable only for LV Threshold test)

For DDD mode, the Normal Brady MTR is used.

NOTE: A long LVPP may inhibit left ventricular pacing at higher pacing rates. LVPP can be temporarily programmed (for example, to a shorter LVPP or Off) through the Pace Threshold Test screen.

5. Watch the ECG display and stop the test by selecting the End Test button or pressing the DIVERT THERAPY key when loss of capture is observed. If the test continues until the programmed number of cycles at the lowest setting have occurred, the test is automatically terminated. The final threshold test value will be displayed (the value is one step above the value when the test was terminated). A 10 second trace (prior to loss of capture) is automatically stored and can be displayed and analyzed by selecting the Snapshot tab ("Snapshot" on page 6-8).

NOTE: *The threshold test result can be edited by selecting the Edit Today's Test button on the Threshold Test screen.*

6. When the test is complete, the threshold measurement will be displayed as the Current measurement (not in parentheses). If the test is repeated during the same session, the Current measurement will be updated with the new result. Note that the Previous Session measurement (displayed in parentheses) is from the most recent past session during which this test was performed.
7. To perform another test, make changes to the test parameter values if desired, then begin again. Results of the new test will be displayed.

NOTE: *The test results from the most recent measurement are stored in pulse generator memory, retrieved during initial interrogation, and displayed on the Lead Tests screen and on the Leads Status screen. The measurements are also provided on the Quick Notes report.*

Commanded Automatic Pace Threshold Test

This feature is available in AUTOGEN devices.

Commanded automatic threshold tests differ from the manual tests in the following ways:

- Commanded automatic threshold tests are available for Amplitude, but not Pulse Width.
- The following parameters are fixed (vs. programmable in manual tests):
 - Paced AV Delay
 - Pulse Width (RAAT and RVAT)
 - Cycles per step
 - LV Protection Period (LVAT)

NOTE: *Change the programmable parameters as desired to elicit pacing in the chamber being tested.*

- If Wireless ECG is enabled for a Quadripolar device, the ECG will temporarily be set to Lead II during commanded LVAT testing.
- Additional event markers are available including loss of capture, fusion, and backup pacing (where backup pacing is available).
- Once started, a commanded automatic threshold test cannot be paused, only cancelled.
- PaceSafe automatically determines when the test is completed and automatically stops the test.
- When complete, the test automatically stops and displays the threshold, which is the last output level that demonstrated consistent capture. A 10 second trace (prior to loss of capture) is automatically stored and can be displayed and analyzed by selecting the Snapshot tab ("Snapshot" on page 6-8).

- Test results cannot be edited.

NOTE: No backup atrial pacing is provided during a commanded automatic right atrial threshold test. RV pacing is provided as backup during a commanded automatic left ventricular threshold test with an applied LV Offset of -80 ms.

LV VectorGuide

This feature is available in AUTOGEN X4, DYNAGEN X4, INOGEN X4, and ORIGEN X4 devices.

LV VectorGuide streamlines the testing required to determine the optimal LV Pacing Lead Configuration for each individual patient. The clinician can quickly evaluate multiple Quadripolar LV pacing vectors and then program the desired configuration.

The following tests are available within the LV VectorGuide screen (Figure 5-5 LV VectorGuide screen on page 5-17) which is accessed from the Lead Tests tab:

- **RVS-LVS Delay:** The LV electrode with the site of latest activation can be determined by performing the RVS-LVS test, which measures the time between an RV sensed and an LV sensed event. LV events are sensed between the selected LV electrode (cathode) and Can.
- **LV Lead Impedance:** LV lead impedance testing uses the same testing methods and results as impedance tests run via the Lead Tests screen ("Lead Impedance Test" on page 5-13).
- **Phrenic Nerve Stimulation (PNS):** Diaphragmatic stimulation from the LV lead can be tested using temporary parameters on the Phrenic Nerve Stimulation test.
- **LV Pace Threshold:** LV Pace Threshold testing accessed from the LV VectorGuide uses the same testing methods and results as threshold tests run via the Lead Tests screen ("Pace Threshold Test" on page 5-14).
- In addition to the manual and commanded threshold tests, the Quick Capture feature is available as a Test Type when LV Threshold Testing is accessed from the LV VectorGuide screen. This feature allows the clinician to quickly evaluate capture in multiple vectors at a fixed pacing output. Manual or Commanded threshold testing can then be performed in the pacing vectors which have a capture threshold below the output used for Quick Capture. This reduces the number of vectors which undergo regular threshold testing and tests can begin at a lower starting amplitude.

NOTE: Commanded Automatic Left Ventricular Pace Threshold testing is available in devices with the LVAT feature.

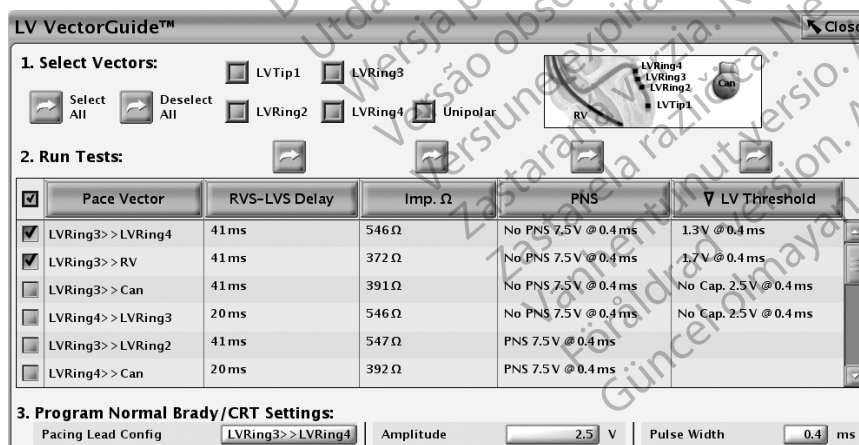

Figure 5-5. LV VectorGuide screen

Use the following steps to perform LV VectorGuide testing (Figure 5–5 LV VectorGuide screen on page 5-17):

1. Select vectors to be tested.

The scroll bar can be used to view all available vectors. Multiple methods are available to control which vectors will be tested:

- Use the Select All button in the Select Vectors area to test all available vectors. The checkboxes next to all available vectors will automatically populate in the Run Tests area.
- Select one or more of the cathodes or Unipolar vectors listed in the Select Vectors area. The checkboxes next to those corresponding vectors will automatically populate in the Run Tests area.
- Individually select the checkbox next to desired vectors in the Run Tests area.
- Use the Deselect All button or deselect individual checkboxes to exclude vectors from testing.

2. Run Test(s).

Select the Run button above the column of the desired test. Where applicable, adjust the temporary parameters on the testing screen based on individual patient characteristics. A notification will be provided if a particular test cannot be attempted.

Tests will run sequentially in each of the selected vectors. Select the Cancel button or follow the on-screen instructions to stop testing and return to the LV VectorGuide screen. Alternatively, pressing the STAT PACE, STAT SHOCK, or DIVERT THERAPY key on the PRM will cancel any testing in progress.

Once testing is complete in all selected vectors, results will be displayed in the corresponding test's column. If the same test is performed multiple times in a particular vector, only the most recent result will be displayed. LV VectorGuide results can be printed via the Reports tab.

Testing details are described below:

• RVS-LVS Delay:

CAUTION: Ensure the patient is clinically capable of tolerating low rate RV Backup Pacing and lack of LV pacing during an RVS-LVS Delay test.

- The patient must have RV and LV sensed beats in order for testing to be successful.
- When testing is complete for a particular cathode, the result will be displayed for all vectors which use that same cathode.
- If testing is unsuccessful for a particular vector, one of the following failure codes will be displayed in the RVS-LVS Delay column:
 - “N/R”: Displayed if too many paced beats, PVCs or noise beats occurred during testing. This will also be displayed if the RV sensed rate is either $< 40 \text{ min}^{-1}$ or $> 110 \text{ min}^{-1}$.
 - “N/R: Unstable RV-LV”
 - “N/R: Unstable RV-RV”

• LV Lead Impedance:

- Impedance results from LV VectorGuide will not overwrite existing results on the Lead Tests screen.
- Phrenic Nerve Stimulation:
 - Select either "Yes PNS" or "No PNS" as appropriate to stop the current test and proceed to the next pacing vector. Perform additional testing at different outputs, as necessary. PNS results will display as "PNS" or "No PNS" at the tested pacing output.
- LV Pace Threshold:

CAUTION: During manual LV Threshold and Quick Capture tests, RV Backup Pacing is unavailable.

- For Quick Capture testing, pacing output will remain constant and not step-down as with other threshold test selections. Select either "Capture" or "No Capture" as appropriate to stop the current test and proceed to the next pacing vector. Results will be displayed as "Cap." or "No Cap." at the tested pacing output.
- Manual or Commanded LV Threshold test results from LV VectorGuide will overwrite the existing result on the Lead Tests screen. But an automatic Snapshot will not occur for LV Threshold tests accessed from the LV VectorGuide screen.

Reduce the number of vectors to be tested and perform additional tests as necessary.

Testing results will be displayed in the appropriate column. Select a column header button to sort the data by that column's values. Vectors with a populated checkbox will be sorted at the top of the list.

Deselect the checkbox for any vectors that will be excluded from consideration and require no further evaluation. Perform additional tests on the remaining vectors as described above.

3. Program the device.

Once the evaluation is complete, use the LV VectorGuide results to select the desired Pacing Lead Configuration, Amplitude, and Pulse Width at the bottom of the screen and select Program.

Остаряла версия. Да не се използва.
Zastaralá verze. Nepoužívat.
Forældet version. Må ikke anvendes.
Version überholt. Nicht verwenden.
Aegunud versioón. Myn την χρησιμοποιείτε.
Παλιά έκδοση. Μην την χρησιμοποιείτε.
Outdated version. Do not use.
Versión obsoleta. No utilizar.
Zastarjela verzija. Nemojte upotrebljavati.
Úreilt útgáfa. Notið ekki.
Versione obsoleta. Ne pas utiliser.
Novecojsi versija. Non utilizzare.
Pasenusi versija. Neizmantot.
Elavult verzió. Ne használja!
Dit is een verouderde versie. Niet gebruiken.
Wersja przeterminowana. Nie używać.
Versão obsoleta. Não utilize.
Versiune expirată. A nu se utiliza.
Zastaraná verzia. Nepoužívať.
Zastarela različica. Ne uporabite.
Vanhentunut versio. Älä käytä.
Föråldrad version. Använd ej.
Güncel olmayan sürüm. Kullanmayın.

PATIENT DIAGNOSTICS AND FOLLOW UP

CHAPTER 6

This chapter contains the following topics:

- “Therapy History” on page 6-2
- “Arrhythmia Logbook” on page 6-2
- “Snapshot” on page 6-8
- “Histograms” on page 6-9
- “Counters” on page 6-10
- “Heart Rate Variability (HRV)” on page 6-11
- “Trends” on page 6-14
- “Post Implant features” on page 6-21

THERAPY HISTORY

The pulse generator automatically records data that can be helpful when evaluating the patient's condition and the effectiveness of pulse generator programming.

Therapy history data can be reviewed at various levels of detail using the PRM:

- Arrhythmia Logbook—provides detailed information for each detected episode ("Arrhythmia Logbook" on page 6-2)
- Histograms and Counters—displays the total number and percentage of paced and sensed events during a particular recording period ("Histograms" on page 6-9 and "Counters" on page 6-10)
- Heart Rate Variability (HRV)—measures changes in the patient's intrinsic heart rate within a 24-hour collection period ("Heart Rate Variability" on page 6-11)
- Trends—provides a graphical view of specific patient, pulse generator, and lead data ("Trends" on page 6-14)

NOTE: The Summary dialog and Summary tab display a prioritized list of events that have occurred since the last reset. This list will only include VF, and VT/VT-1 and ATR (if it lasted more than 48 hours) episodes, and MRI Protection Mode events.

ARRHYTHMIA LOGBOOK

This feature is available in AUTOGEN, DYNAGEN, INOGEN, ORIGEN, INCEPTA, ENERGEN, PUNCTUA, and COGNIS devices.

The Arrhythmia Logbook provides access to the following detailed information about episodes of all types (Figure 6-1 Arrhythmia Logbook screen on page 6-3):

- The number, date, and time of the event
- The type of event with tachyarrhythmia zone
- A summary of therapy delivered or attempted (if applicable)
- Duration of the event (when applicable)
- Electrograms with annotated markers
- Intervals

NOTE: The data include information from all active electrodes. The device compresses the history data to store a maximum of 17 minutes of electrogram data (13 minutes with Patient Triggered Monitor enabled). However, the amount of time actually stored may vary based on the data being compressed (e.g., noise on the EGM or an episode of VF).

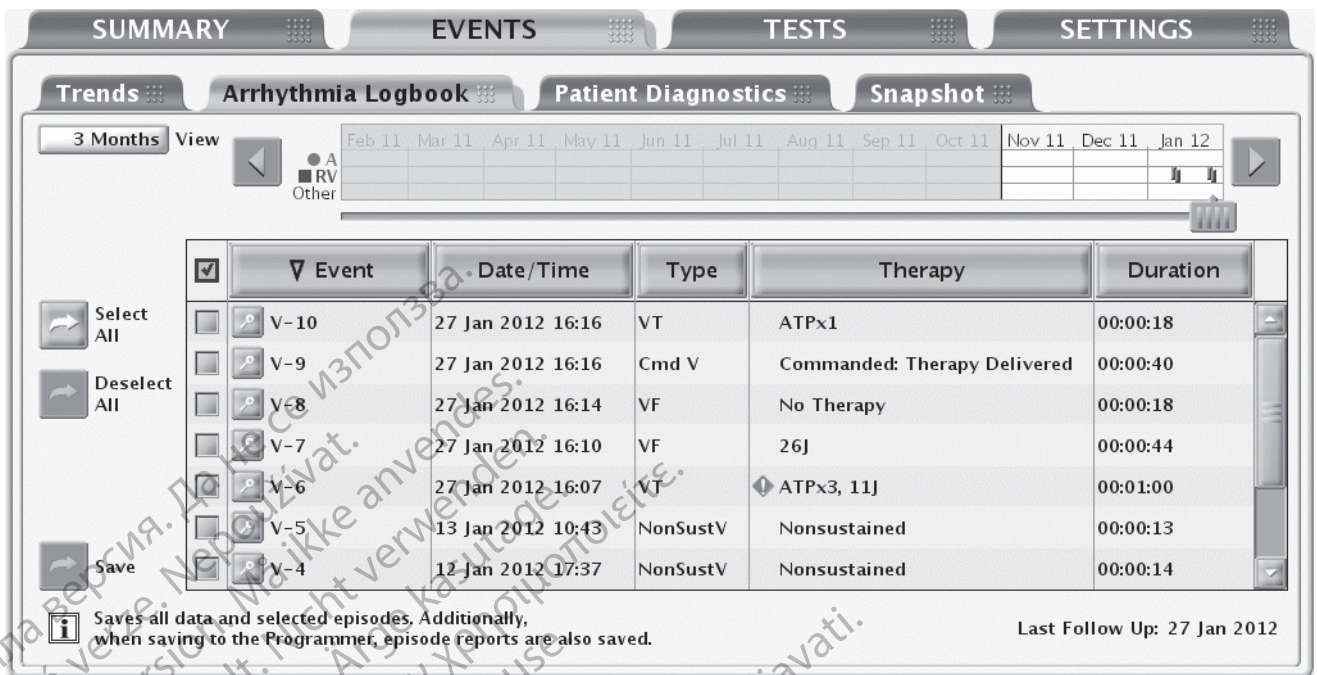

Figure 6-1. Arrhythmia Logbook screen

The priority, maximum number, and minimum number of episodes that the pulse generator stores under normal conditions varies by episode type (Table 6-1 Episode Priority on page 6-4). As long as device memory allocated for episode data is not full, the pulse generator stores up to the maximum number of episodes allowed for each episode type. The minimum number of episodes for each episode type ensures that all episode types are represented by protecting a few low priority episodes from being overwritten by high priority episodes when device memory is full.

Once device memory is full, the pulse generator attempts to prioritize and overwrite stored episodes according to the following rules:

1. If device memory is full, and there are episodes older than 18 months, then the oldest of the lowest priority episodes from these episode types will be deleted (regardless if the minimum number of episodes are stored).
 2. If device memory is full, and there are episode types that have more than the minimum number of episodes stored, then the oldest of the lowest priority episodes from these episode types will be deleted. In this case, the low priority episodes are not deleted if their number of stored episodes is less than the minimum number.
 3. If device memory is full, and there are no episode types that have more than the minimum number of episodes stored, then the oldest of the lowest priority episodes of all episode types will be deleted.
 4. If the maximum number of episodes has been reached within an episode type, the oldest episode of that type will be deleted.
- For non-commanded episodes, the episode type for VT-1, VT, and VF episodes is determined according to the zone Duration that expires first. If no zone Duration expires during an episode, the episode type is Nonsustained.
 - An episode in progress has the highest priority until its type can be determined.

NOTE: Once history data is saved, it can be accessed at any time without device interrogation.

Table 6–1. Episode Priority

Episode Type	Priority	Maximum number of stored episodes	Minimum number of stored episodes with detailed reports	Maximum number of stored episodes with detailed reports
VF/VT/VT-1 with shock ^a	1	50	5	30
PTM (Patient Triggered Monitor)	1	5	1	1
VF/VT/VT-1 with ATP ^{b e}	2	30	2	15
VF/VT/VT-1 with no therapy (Duration Met) ^c	3	20	1	10
Cmd V	4	2	0	2
NonSustV (Duration not met)	4	10	0	2
RA Auto	4	1	1	1
RV Auto	4	1	1	1
LV Auto	4	1	1	1
ATR	4	10	1	3
PMT	4	5	1	3
APMRT ^d	4	1	1	1

- a. May also include ATP therapy.
- b. ATP without shock therapy.
- c. No therapy defined as Duration Met with: an Inhibit decision, detection in the Monitor Only zone, the last sensed interval not in the zone, or a Divert-Reconfirm.
- d. Advanced Patient Management real time (APMRT) events are presenting EGMs, captured and stored on the pulse generator during LATITUDE Communicator follow-ups.
- e. Quick Convert ATP in the VF zone is only available in some devices.

To display Arrhythmia Logbook data, use the following steps:

1. From the Events tab, select Arrhythmia Logbook. If necessary, the pulse generator will be automatically interrogated and current data will be displayed. Saved patient data also can be displayed ("Data Storage" on page 1-18).
2. While retrieving the data, the programmer will display a window indicating the progress of the interrogation. No information will be displayed if you select the Cancel button before all of the stored data are retrieved.
3. Use the slider and View button to control the range of dates for the events you want to display in the table.
4. Select the Details button of an event in the table to display the event details. Event details, available if the details button is present, are useful in evaluating each episode. The Stored Event screen will appear, and you can browse between the following tabs for more information about the event:
 - Events Summary
 - EGM
 - Intervals
5. Select a column header button to sort the events by that column. To reverse the order, select the column header again.

- To save specific events, select the event and choose the Save button. To print specific events, select the event and choose Reports from the toolbar. Choose the Selected Episodes report and select the Print button.

NOTE: An “in-progress” episode will not be saved; an episode must be complete before it will be saved by the application.

To view episode details, select the Details button next to the desired episode on the Arrhythmia Logbook screen. The Stored Event screen will appear, and you can browse between the Summary, EGM, and Intervals tabs.

Events Summary

The Events Summary screen displays additional details about the selected episode corresponding to the Arrhythmia Logbook.

The summary data may include the following:

- Episode number, date, time, type (e.g., VF, VT, VT-1, spontaneous/Induced, or PTM)
- Average atrial and ventricular rates
- Type of therapy delivered
 - For ATP therapy, the time of therapy delivery and the number of bursts
 - For shock therapy, the start time of charging, charge time, impedance, and energy level
- Duration
- Atrial rate at PMT start (PMT events only)

Stored Electrograms with Annotated Markers

The pulse generator can store annotated electrograms sensed from the following leads prior to the onset of an episode, around duration met, and around therapy start and end:

- Shock lead
- RV pace/sense lead
- LV pace/sense lead

NOTE: LV electrograms are only stored for PTM and APM RT episodes. LV markers are always stored when available, regardless of episode type.

- Atrial pace/sense lead
- PaceSafe Evoked Response (ER) (PaceSafe episodes only)

The particular annotated electrograms stored depend upon the episode type. In this section, EGM refers to both electrograms and the associated annotated markers. The EGM storage capacity varies depending on EGM signal condition and heart rate. The total amount of stored EGM data associated with an episode may be limited; EGMs from the middle of the episode may be removed for episodes greater than 4 minutes in duration.

When the memory allocated to EGM storage is full, the device overwrites older EGM data segments in order to store the new EGM data. The EGM is recorded in segments consisting of episode Onset, Attempt, and End EGM Storage. Each segment of data is visible when the left caliper is in the specific section.

The following information is retained:

- Onset retains up to 25 seconds of data prior to Duration expiring
- Reconfirmation retains up to 20 seconds of data prior to therapy delivery
- Therapy data is displayed. In the case of ATP therapy, up to 20 seconds of at least the first and last burst for each scheme will be retained
- Post-therapy or diverted therapy retains up to 10 seconds of data

Episode Onset refers to the period of time (measured in seconds) of EGM prior to the first attempt.

Onset includes the following information:

- Type of event
- Average RA Rate at the start of Event
- Average RV Rate at the start of Event
- Programming of Detection Enhancements (Rate Only, Rhythm ID, or Onset/Stability)
- Acquisition timestamp of Rhythm ID reference template (AUTOGEN, DYNAGEN, and INCEPTA devices)
- RhythmMatch Threshold (as programmed) (AUTOGEN, DYNAGEN, and INCEPTA devices)
- Measured RhythmMatch value (if a reference template has been acquired, the event has no attempts, and the pulse generator inhibited therapy) (AUTOGEN, DYNAGEN, and INCEPTA devices)

Attempt information may be displayed as Attempt or In Progress, if an attempt is in progress.

Attempt includes the following information:

- Detection information:
 - Average RA Rate at start of Attempt
 - Average RV Rate at start of Attempt
 - Rate Zone
- Measured Values of Detection Enhancements
- Therapy Attempt Information:
 - Attempt Number
 - Type (aborted, commanded, or inhibited)
 - Number of bursts (ATP attempt)
 - Charge Time (shock attempt)
 - Lead impedance (shock attempt)
 - Lead Polarity (shock attempt)
 - Shock faults (shock attempt)
 - Reason for No Therapy

The End EGM Storage starts following therapy delivery and stores up to 10 seconds of EGM. The following figure shows the relationship between the ventricular tachy episode EGM storage and surface ECG strip chart recording for AUTOGEN, DYNAGEN, INOGEN, and ORIGEN devices (Figure 6–2 Relationship between ventricular tachy episode EGM storage and surface ECG strip chart recording on page 6-7).

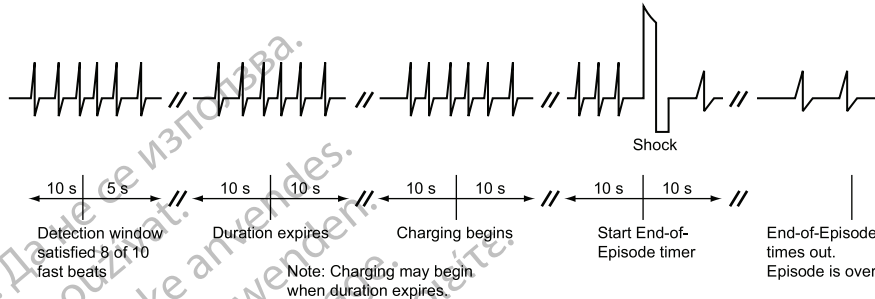

Figure 6–2. Relationship between ventricular tachy episode EGM storage and surface ECG strip chart recording

The following figure shows the relationship between the ventricular tachy episode EGM storage and surface ECG strip chart recording for INCEPTA, ENERGEN, PUNCTUA, and COGNIS devices (Figure 6–3 Relationship between ventricular tachy episode EGM storage and surface ECG strip chart recording on page 6-7).

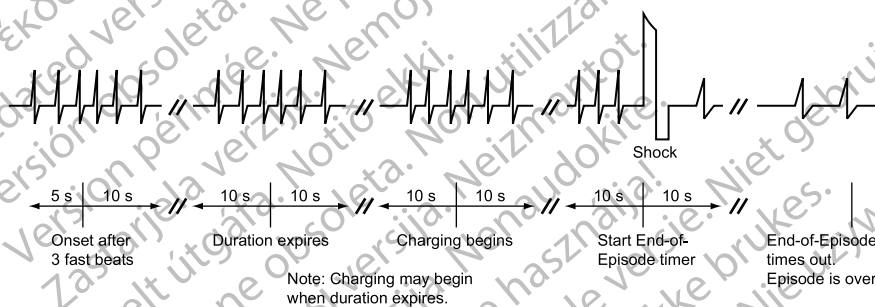

Figure 6–3. Relationship between ventricular tachy episode EGM storage and surface ECG strip chart recording

NOTE: Refer to "Use of Atrial Information" on page 2-6 for additional information about device performance when the atrial lead is programmed to Off.

To view the EGM data, select the Details button of the desired episode on the Arrhythmia Logbook screen.

Use the following steps to view specific details about each episode:

1. Select the EGM tab.
 - EGM strips for the appropriate sources are displayed. Each strip includes the EGMs sensed during the episode with the corresponding annotated markers. Blue vertical bars indicate the segment (Onset, Attempt, End) boundaries.

NOTE: For marker definitions, select the Reports button on the PRM and view the Marker Legend Report.

- Use the slider under the upper display window to view different sections of the stored EGM.

- Adjust the trace Speed as needed (10, 25, 50, 100 mm/s). As the Speed is increased, the time/horizontal scale is expanded.

NOTE: Adjusting the trace Speed is for on-screen viewing only; the print speed of a stored EGM is set to 25 mm/s.

- Use the electronic caliper (slider bar) to measure the distance/time between signals as well as measure the amplitude of signals.
 - The distance between signals can be measured by moving each caliper to the desired points on the EGM. The time (in milliseconds or seconds) between the two calipers will be displayed.
 - The amplitude of the signal can be measured by moving the left-hand caliper over the peak of the desired signal. The value (in millivolts) of the signal will be displayed on the left side of the EGM. The signal is measured from baseline to peak, either positive or negative. Adjust the trace Speed and/or amplitude scale as needed to help facilitate an amplitude measurement.
 - Adjust the amplitude/vertical scale as needed (0.2, 0.5, 1, 2, 5 mm/mV) for each channel using the up/down arrow buttons located on the right side of the trace display. As the gain is increased, the amplitude of the signal is enlarged.
2. Select the Previous Event or Next Event button to display a different event strip.
 3. To print the entire episode report, select the Print Event button. To save the entire episode report, select the Save button.

Intervals

The pulse generator stores event markers and associated time stamps. The PRM derives event intervals from the event markers and time stamps.

To view the episode intervals, use the following steps:

1. From the Stored Event screen, select the Intervals tab. If all of the episode data is not visible in the window, use the scroll bar to view more data.
2. Select the Previous Event or the Next Event button to display a previous or more current episode, one episode at a time.
3. Select the Print Event button to print the entire episode report.
4. Select the Save button to save the entire episode report.

SNAPSHOT

This feature is available in AUTOGEN, DYNAGEN, INOGEN, ORIGEN, INCEPTA, ENERGEN, PUNCTUA, and COGNIS devices.

A 12 second trace of the ECG/EGM display can be stored at any time by pressing the Snapshot button from any screen. A trace is also automatically stored following a Pace Threshold Test. After a trace has been stored, it can be displayed and analyzed by selecting the Snapshot tab.

The traces which are currently selected on the ECG/EGM display as well as annotated markers will be captured for up to 10 seconds before and up to 2 seconds after the Snapshot button was selected. If a Snapshot was automatically stored during a Pace Threshold Test, it will be 10 seconds long, ending with the termination of the test.

NOTE: The Snapshot length will be reduced if the traces on the ECG/EGM display are changed or the session started within 10 seconds of selecting the Snapshot button.

Up to 6 time-stamped Snapshots will be stored in the PRM memory for the current session only. Once the session has been terminated by exiting the application software or by interrogating a new patient, the data will be lost. If more than 6 Snapshots are stored in one PRM session, the oldest will be overwritten.

Use the following steps to view a stored Snapshot:

1. From the Events tab, select the Snapshot tab.
2. Select the Previous Snapshot or Next Snapshot button to display a different trace.
3. Use the slider under the upper display window to view different sections of the stored Snapshot.
4. Adjust the Speed as needed (10, 25, 50, 100 mm/s). As the Speed is increased, the time/horizontal scale is expanded.

NOTE: Adjusting the Speed is for on-screen viewing only; the print speed of a stored Snapshot is set to 25 mm/s.

5. Use the electronic caliper (slider bar) to measure the distance/time between signals as well as measure the amplitude of signals.
 - The distance between signals can be measured by moving each caliper to the desired points on the Snapshot. The time (in milliseconds or seconds) between the two calipers will be displayed.
 - The amplitude of the signal can be measured by moving the left-hand caliper over the peak of the desired signal. The value (in millivolts) of the signal will be displayed on the left side of the Snapshot. The signal is measured from baseline to peak, either positive or negative. Adjust the Speed and/or amplitude scale as needed to help facilitate an amplitude measurement.
6. Adjust the amplitude/vertical scale as needed (0.2, 0.5, 1, 2, 5 mm/mV) for each channel using the up/down arrow buttons located on the right side of the trace display. As the gain is increased, the amplitude of the signal is enlarged.
7. To print the Snapshot that is currently being viewed, select the Print button. To save the Snapshot that is currently being viewed, select the Save button. Select Save All Snapshots to save all stored Snapshot traces.

HISTOGRAMS

This feature is available in AUTOGEN, DYNAGEN, INOGEN, ORIGEN, INCEPTA, ENERGEN, PUNCTUA, and COGNIS devices.

The Histograms feature retrieves information from the pulse generator and displays the total number and percentage of paced and sensed events for the chamber.

Histograms data can provide the following clinical information:

- The distribution of the patient's heart rates
- How the ratio of paced to sensed beats varies by rate
- How the ventricle responds to paced and sensed atrial beats across rates

When combined with verified biventricular capture, Histograms can be used to determine the amount of CRT delivery. The percentage of paced and sensed ventricular events indicates the percentage of BiV pacing delivered.

Use the following steps to access the Histograms screen:

1. From the Events screen, select the Patient Diagnostics tab.
2. The initial display shows the paced and sensed data since the last time the counters were reset.
3. Select the Details button to display the data type and time period.
4. Select the Rate Counts button on the Details screen to view rate counts by chamber.

All Histograms can be reset by selecting the Reset button from any Patient Diagnostics Details screen. Histogram data can be saved to the PRM and printed via the Reports tab.

COUNTERS

This feature is available in AUTOGEN, DYNAGEN, INOGEN, ORIGEN, INCEPTA, ENERGEN, PUNCTUA, and COGNIS devices.

The following counters are recorded by the pulse generator and displayed on the Patient Diagnostics screen:

- Ventricular Tachy
- Brady/CRT

Ventricular Tachy Counters

Information about Ventricular Tachy Counters is available by selecting the Ventricular Tachy Counters Details button. This screen displays Ventricular Episode, Ventricular Therapy, and Clinical counters. For each counter, the number of events since last reset and device totals are displayed. Ventricular Tachy Episode counters contains the following data:

- Total Episodes
- Treated—VF, VT, VT-1, and Commanded
- Non-Treated—No Therapy Programmed, Nonsustained, and Other Untreated Episodes

Ventricular Tachy Therapy counters consist of ventricular shock and ATP therapy attempts. They can provide useful data about the effectiveness of a patient's therapy prescription. These counters include the following information:

- ATP Delivered
- ATP % Successful—the percent of time that the arrhythmia is converted and the episode ends without delivery of a programmed shock
- Shocks Delivered
- First Shock % Successful—the percent of time that the arrhythmia is converted and the episode ends without requiring a second programmed shock
- Shocks Diverted

The ventricular ATP counter is incremented at the start of the delivery of the first burst of an ATP scheme. Subsequent ATP bursts in the same scheme are not counted individually during the same episode. An ATP scheme is counted as diverted only if it is diverted prior to delivery of the first burst.

The MRI Counters within the Clinical Counters section displays the number of times the device was programmed into MRI Protection Mode, regardless if an MRI scan was performed (available only in MR Conditional devices).

Brady/CRT Counters

Information about Brady/CRT Counters are displayed by selecting the Brady/CRT Counters Details button. This screen displays the Brady/CRT episode counters. For each counter, the number of events since last reset and reset before last are displayed. Brady/CRT Counters contains the following details:

- Percent of atrial paced
- Percent of RV paced

NOTE: *The RV pace event for a BiVentricular Trigger pace will be counted as an RV sense.*

- Percent of LV paced
- Intrinsic Promotion—includes Rate Hysteresis % Successful
- Atrial Burden—includes percentage of time the device was in ATR, Episodes by Duration and Total PACs

NOTE: *Atrial Burden % records and displays data for a maximum of one year.*

- Ventricular Counters—includes Total PVCs and Three or More PVCs

All Counters can be reset by selecting the Reset button from any Patient Diagnostics Details screen. Counter data can be saved to the PRM and printed via the Reports tab.

HEART RATE VARIABILITY (HRV)

This feature is available in AUTOGEN, DYNAGEN, INOGEN, ORIGEN, INCEPTA, ENERGEN, PUNCTUA, and COGNIS devices.

Heart Rate Variability (HRV) is a measure of the changes in a patient's intrinsic heart rate within a 24-hour collection period.

This feature can assist in evaluating the clinical status of heart failure patients.

HRV, as measured by SDANN and HRV Footprint, is an objective, physiological measure that can identify heart failure patients at higher risk of mortality. Specifically, depressed HRV can be used as a predictor of risk of mortality after an acute myocardial infarction.¹ A normal SDANN value is 127 plus or minus 35 ms.¹ Higher SDANN values (indicating greater variability of heart rate) have been associated with lower risk of mortality.^{2 3 4} Similarly, a larger HRV Footprint also indicates greater heart rate variability and has been associated with lower mortality risk.^{2 3 4}

1. Electrophysiology Task Force of the European Society of Cardiology and the North American Society of Pacing and Electrophysiology. *Circulation*, 93:1043-1065, 1996.
2. F.R. Gilliam et al., *Journal of Electrocardiology*, 40:336-342, 2007.
3. F.R. Gilliam et al., *PACE*, 30:56-64, 2007.
4. J.P. Singh et al., *Europace*, 12:7-8, 2010.

The HRV monitor feature provides the following information using the intrinsic interval data from the 24-hour collection period that meets the HRV collection criteria (Figure 6–4 Heart Rate Variability display on page 6-12):

- Date and time the 24-hour collection period was completed.
- % of Time Used—displays the percentage of time during the 24-hour collection period in which there are valid intrinsic beats. If the % of Time Used falls below 67%, data will not be displayed for that collection period.
- HRV Footprint plot—shows the percentage of the graph area used by the HRV plot. The graph area portrays an “at-a-glance snapshot” of the distribution of variability versus heart rate over a 24-hour period. The trended percentage is a normalized score based on the footprint in the graph.
- Standard Deviation of Averaged Normal R to R intervals (SDANN)—the HRV collection period comprises 288 5-minute segments (24-hours) of intrinsic intervals. The SDANN is the standard deviation of the averages of intrinsic intervals in the 288 5-minute segments. This measurement is also available in the Trends.
 - Current Normal Brady/CRT parameters—Mode, LRL, MTR, Sensed AV Delay, and Pacing Chamber with LV Offset.
 - An HRV plot for current and previous collection periods including a line that shows the mean heart rate. The HRV plot summarizes the cardiac variation on a cycle-to-cycle basis. The x-axis shows the heart rate range, the y-axis shows the beat-to-beat variability displayed in milliseconds. The color indicates the frequency of beats at any particular heart rate and heart rate variability combination.

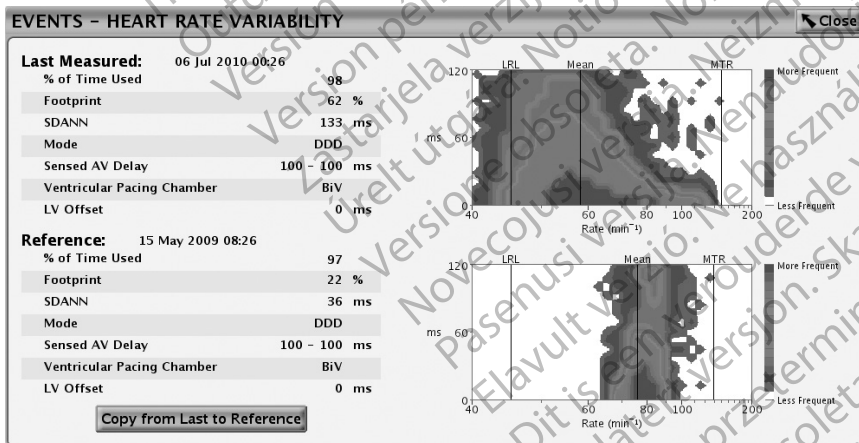

Figure 6–4. Heart Rate Variability display

Consider the following information when using HRV:

- The cardiac cycle (R–R interval) in HRV is determined by RV sensed and paced events (LV paced events when the Pacing Chamber is programmed to LV Only).
- Programming the pacing parameters causes the data acquired for the current 24-hour collection period to be invalid.
- The device saves only one set of values and corresponding HRV plot for the Reference portion of the screen. Once the values are copied from Last Measured to Reference, older data cannot be retrieved.

- The first time the HRV feature is used, the Reference screen will show the data from the first valid 24-hour collection period.

Follow the steps below to view HRV:

1. To access the HRV monitor screen, select the Events tab.
2. From the Events screen, select the Patient Diagnostics tab.
3. Select the Heart Rate Variability Details button to view the Last Measured and Reference data.
4. To copy the Last Measured HRV measurements into the Reference section, select the Copy From Last to Reference button.

The HRV monitor screen displays a set of measurements and a HRV plot based on the most recent 24-hour collection period in the Last Measured portion of the screen; measurements from a previously saved collection period are displayed in the Reference portion of the screen. Both collection periods can be viewed simultaneously to compare data that could show trends in the patient's HRV changes over a period of time. By saving the Last Measured values to the Reference portion of the screen, you can view the last measured data during a later session.

HRV Collection Criteria

Only valid sinus rhythm intervals are used in the HRV data calculations. For HRV, valid intervals are those which include only valid HRV events.

Valid HRV events are listed below:

- AS with an interval not faster than MTR, followed by a VS
- AS followed by VP at the programmed AV Delay

Invalid HRV events are as follows:

- AP/VS or AP/VP
- AS with an interval faster than MTR
- Non-tracked VP events
- Consecutive AS events (no intervening V event)
- VP-Ns
- Rate Smoothing events (e.g., RVP↑)
- PVC

HRV data may not be reported for a variety of reasons; the most common are as follows:

- Brady Mode is not DDD or VDD (COGNIS devices)
- Less than 67% of the 24-hour collection period (approximately 16 hours) contains valid HRV events
- Brady Parameters were programmed within the last 24 hours

An example of how HRV data is recorded is shown (Figure 6–5 Example of HRV data collection on page 6-14). In this example, the HRV data in the first collection period is invalid because the Brady Parameters were programmed after the device was taken out of Storage. HRV data is successfully calculated and reported at the end of the second 24-hour collection period. Subsequent HRV data is not reported until the end of Collection Period 5.

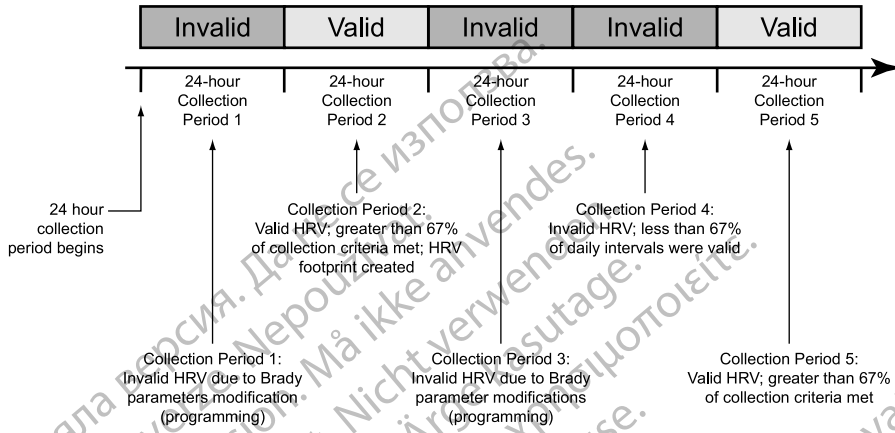

Figure 6–5. Example of HRV data collection

TRENDS

Trends provide a graphical view of specific patient, device, and lead data. This data can be useful when evaluating your patient's condition and the effectiveness of programmed parameters. Unless otherwise noted below, data for all trends is reported every 24 hours and is available for up to 1 year. For many trends, a value of "N/R" is reported if there is insufficient or invalid data for the collection period.

The following trends are available:

- **Events**—displays both atrial and ventricular events stored in the Arrhythmia Logbook, organized by date and type ("Arrhythmia Logbook" on page 6-2). This trend is updated whenever an episode is completed, and may contain data that is older than 1 year.
- **Activity Level**—displays a measure of the patient's daily activity represented by the "Percent of Day Active".
- **Atrial Burden**—displays a trend of the total number of ATR Mode Switch events and the total amount of time spent in an ATR Mode Switch per day.
- **Respiratory Rate**—displays a trend of the patient's daily minimum, maximum, and median respiratory rate values ("Respiratory Rate Trend" on page 6-16). For COGNIS devices, the Respiratory Rate trend is not currently available for use. It cannot be turned on, nor will the trend graph have any data.
- **AP Scan/ApneaScan**—displays a trend of the average number of respiratory disturbance events as measured by the pulse generator that the patient experiences per hour during the programmed sleep period ("AP Scan/ApneaScan" on page 6-16).
- **Heart Rate**—displays a trend of the patient's daily maximum, mean, and minimum heart rate. Intervals used in this calculation must be valid sinus rhythm intervals.

The validity of an interval and the Heart Rate Trend data for the 24-hour collection period is determined by the HRV collection criteria ("Heart Rate Variability" on page 6-11).

- SDANN (Standard Deviation of Averaged Normal-to-Normal R-R intervals)—displays a trend of the standard deviation of the averages of intrinsic intervals over the 24-hour collection period (which is comprised of 288 5-minute segments). Only intervals that meet the HRV collection criteria are considered valid.

A normal SDANN value is 127 plus or minus 35 ms.⁵

- HRV Footprint—displays the percentage of the graph area used by the HRV Footprint plot, illustrating the distribution of variability versus heart rate over a 24-hour period. The trended percentage is a normalized score based on the footprint in the graph. Refer to additional information about HRV ("Heart Rate Variability" on page 6-11).
- ABM (Autonomic Balance Monitor)—displays a trend of the LF/HF ratio.⁶ Normal range for the LF/HF ratio is 1.5 - 2.0.⁷ ABM is a device calculation based on R-R interval measurements, which mathematically functions as a surrogate measurement for LF/HF ratio. Intervals used in the calculation must be valid sinus rhythm intervals as determined by the HRV collection criteria. If the HRV data is invalid for the 24-hour collection period, then the ABM is not calculated and a value of "N/R" is displayed.
- Lead impedance and amplitude—displays trends of the daily intrinsic amplitude and lead impedance measurements ("Leads Status" on page 5-7).
- A Pace Threshold—displays a trend of the daily right atrial pacing thresholds.
- RV Pace Threshold—displays a trend of the daily right ventricular pacing thresholds.
- LV Pace Threshold—displays a trend of the daily left ventricular pacing thresholds.

Follow the steps below to access Trends:

1. From the Events screen, select the Trends Tab.
2. Choose the Select Trends button to specify the trends you want to view. You can choose from the following categories:

- Heart Failure—includes Heart Rate, SDANN, and HRV Footprint trends.
- Atrial Arrhythmia—includes Events, Heart Rate, and Atrial Burden trends.
- Activity—includes Heart Rate, Activity Level, and Respiratory Rate trends.

NOTE: For COGNIS devices, Respiratory Rate trend is not currently available for use. It cannot be turned on, nor will the trend graph have any data.

- Custom—allows you to select various trends to customize the information displayed on the Trends screen.

The display on the screen can be viewed in the following manner:

- Select the desired time on the View button to choose the length of visible trend data.

5. Electrophysiology Task Force of the European Society of Cardiology and the North American Society of Pacing and Electrophysiology. *Circulation*, 93:1043-1065, 1996.
6. Parasympathetic tone is primarily reflected in the high-frequency (HF) component of spectral analysis. The low-frequency (LF) component is influenced by both the sympathetic and parasympathetic nervous systems. The LF/HF ratio is considered a measure of sympathovagal balance and reflects sympathetic modulations. (Source: ACC/AHA Guidelines for Ambulatory Electrocardiography—Part III, JACC VOL. 34, No. 3, September 1999:912-48).
7. Electrophysiology Task Force of the European Society of Cardiology and the North American Society of Pacing and Electrophysiology. *Circulation*, 93:1043-1065, 1996.

- Adjust the start and end dates by moving the horizontal slider at the top of the window. You can also adjust these dates using the scroll left and scroll right icons.
- Move the vertical axis across the graph by moving the horizontal slider at the bottom of the display window.

Respiratory Rate Trend

This feature is available in AUTOGEN, DYNAGEN, INOGEN, INCEPTA, and ENERGEN devices.

The Respiratory Rate trend displays a graph of the patient's daily minimum, maximum, and median respiratory rate values. These daily values are stored for up to one year to create a longitudinal display of physiological data.

NOTE: *The American College of Cardiology (ACC)/American Heart Association (AHA) guidelines recommend the measurement and documentation of physiological vital signs including respiratory rate for cardiac patients.⁸*

Ensure the MV/Respiratory Sensor is programmed to On (or Passive for the MV Sensor) for Respiratory Rate trend data to be collected and displayed ("Minute Ventilation (MV)/Respiratory Sensor" on page 6-17).

Move the horizontal slider over a data point to view the values for a given date. At least 16 hours of data must be collected for values to be calculated and plotted to the Respiratory Rate trend. If insufficient data was collected, no data point will be plotted and there will be a gap in the trend line. This gap will be labeled as N/R to indicate that insufficient or no data was collected.

AP Scan/ApneaScan

The AP Scan feature is available in AUTOGEN and DYNAGEN devices. The ApneaScan feature is available in INCEPTA devices.

AP Scan/ApneaScan is a trend of the average number of respiratory disturbance events as measured by the pulse generator that the patient experiences per hour during the programmed sleep period. This trend is not intended to diagnose patients with sleep apnea. Standard clinic methods such as polysomnogram should be used for actual diagnosis. Data provided by this trend can be used along with other clinical information to follow changes in patients who may be at high risk for sleep-disordered breathing.

This feature is modeled after accepted sleep clinic scoring methodologies for detection of apnea and hypopnea⁹. The pulse generator considers a respiratory disturbance event to be a 26% or greater reduction in respiratory signal amplitude, lasting at least 10 seconds. The average is calculated by dividing the total number of respiratory disturbance events observed during the programmed sleep period by the number of hours in the sleep period. These averages are plotted once a day to the trend.

Consider the following when using AP Scan/ApneaScan:

- To aid in interpreting the trend, a threshold is displayed on the graph at 32 average events per hour. This threshold is intended to approximately correlate to a clinical threshold for severe apnea. Data points above this threshold may indicate the need to further investigate the presence of severe sleep-disordered breathing.
- Respiratory signal amplitude can be affected by factors such as patient posture or movement.

8. ACC/AHA Heart Failure Clinical Data Standards. *Circulation*, Vol. 112 (12), September 20, 2005.

9. Meoli et al., *Sleep*, Vol. 24 (4), 469–470, 2001.

- The accuracy of the trend can be diminished under any of the following conditions:
 - The patient is not asleep during part or all of the defined sleep period
 - The patient experiences milder sleep-disordered breathing that the pulse generator cannot accurately detect
 - The patient has low respiratory signal amplitudes, making it difficult for the pulse generator to detect respiratory disturbance events
 - The patient is receiving treatment for sleep apnea (e.g., continuous positive airway pressure therapy)

To activate AP Scan/ApneaScan, perform the following steps:

1. Ensure the MV/Respiratory Sensor is programmed to On (or Passive for the MV Sensor) ("Minute Ventilation (MV)/Respiratory Sensor" on page 6-17).
2. Program the following Sleep Schedule parameters (available on the General tab of the Patient Information screen):

- Sleep Start Time—time when you expect the patient to typically fall asleep each night
- Sleep Duration—amount of time you expect the patient to typically sleep each night

NOTE: Ensure the MV/Respiratory Sensor is programmed to On (or Passive for the MV Sensor) to activate AP Scan/ApneaScan. Programming the Sleep Schedule parameters will have no effect if the MV/Respiratory Sensor is Off.

To increase the likelihood that the patient is sleeping during data collection, the pulse generator does not begin collecting data until 1 hour after the Sleep Start Time, and stops collecting data 1 hour before the Sleep Duration period would otherwise have expired.

Example: If you select a Sleep Start Time of 22:00 and a Sleep Duration of 8 hours, the pulse generator will monitor for respiratory disturbance events starting at 23:00 and stopping at 05:00.

Move the horizontal slider over a data point to view the average for a given date. At least 2 hours of data must be collected for an average to be calculated and plotted to the trend. If insufficient data was collected, no data point will be plotted and there will be a gap in the trend line. This gap will be labeled as N/R to indicate that insufficient or no data was collected.

Minute Ventilation (MV)/Respiratory Sensor

The following Minute Ventilation (MV)/Respiratory Sensor information applies to AUTOGEN, DYNAGEN, and INOGEN devices.

The Minute Ventilation (MV) feature is available in AUTOGEN devices. The Respiratory Sensor is available in DYNAGEN and INOGEN devices.

The MV/Respiratory Sensor uses transthoracic impedance measurements to collect respiration-related data for use in generating the Respiratory Rate and AP Scan/ApneaScan trends.

CAUTION: Program the MV/Respiratory Sensor to Off during mechanical ventilation. Otherwise, the following may occur:

- Inappropriate MV sensor-driven rate
- Misleading respiration-based trending

Approximately every 50 ms (20 Hz), the pulse generator drives a current excitation waveform between the RA Ring electrode and Can (primary vector). The application of the current between these electrodes creates an electrical field (modulated by respiration) across the thorax. During

inspiration, the transthoracic impedance is high, and during expiration it is low. The pulse generator will detect the resulting voltage modulations between the RA Tip electrode and Can. Due to advanced filtering, breathing rates up to 72 (MV Sensor) or 65 (Respiratory Sensor) breaths per minute are supported.

CAUTION: Any medical equipment, treatment, therapy, or diagnostic test that introduces electrical current into the patient has the potential to interfere with pulse generator function.

- External patient monitors (e.g., respiratory monitors, surface ECG monitors, hemodynamic monitors) may interfere with the pulse generator's impedance-based diagnostics (e.g., shock lead impedance measurements, Respiratory Rate trend). This interference may also result in accelerated pacing, possibly up to the maximum sensor-driven rate, when MV is programmed to On. To resolve suspected interactions with the MV sensor, deactivate the sensor either by programming it to Off (no MV rate driving or MV sensor-based trending will occur), or Passive (no MV rate driving will occur). Alternatively, program the Brady Mode to a non-rate responsive mode (no MV rate driving will occur).

To resolve suspected interactions with Respiratory Sensor-based diagnostics, deactivate the pulse generator's Respiratory Sensor by programming it to Off.

NOTE: *The MV Sensor signal does not cause an increase in heart rate if it is programmed to Passive. The Respiratory Sensor signal does not cause an increase in heart rate.*

Consider the following when programming the sensor:

- Examine real-time EGMs before and after activating the sensor. The sensor signal can sometimes be observed on EGMs.

CAUTION: If MV/Respiratory Sensor signal artifacts are observed on EGMs, and the leads are otherwise shown to be performing appropriately, consider programming the sensor to Off to prevent oversensing.

- Program the sensor to Off if you detect or suspect any loss of lead integrity.

CAUTION: Do not program the MV sensor to On until after the pulse generator has been implanted and system integrity has been tested and verified.

The pulse generator may temporarily suspend the sensor in the following circumstances:

- Ventricular Tachy episode is declared (8 out of 10 fast beats)—The sensor will be suspended for the duration of the episode. Once the episode has ended, MV driven pacing will resume unless an automatic 6-hour calibration occurs due to a long episode or out of range lead impedances (test performed at end of episode).
- Excessive electrical noise levels—The pulse generator continuously monitors electrical noise levels. The sensor is temporarily suspended if noise is excessive (the MV Sensor Status will indicate Suspended: Noise Detected), and is turned on again when noise decreases to an acceptable level.
- Loss of lead integrity—Lead impedances for the sensor are evaluated hourly (separate from daily lead measurements). If either impedance measurement is out of range, the following occurs:
 - The pulse generator evaluates the lead impedance for a secondary vector driven from the RV Coil to the Can, and measured from the RV Tip electrode to the Can. If this impedance measurement is in range, the sensor reverts to this secondary vector. If the lead impedance is also out of range with the secondary vector, the sensor is temporarily suspended until the next lead impedance evaluation.

NOTE: If an RA lead is not used, only the secondary vector is available.

- The pulse generator will continue to monitor lead impedance hourly to determine if the sensor should be returned to the primary or secondary vector, or remain suspended. Acceptable lead impedance values are 200–2000 Ω for the tip to can vector, 100–1500 Ω for the ring to can vector, and 20–200 Ω for the RV Coil to Can vector.

To program the MV Sensor, use the following steps:

1. From the Settings tab on the main screen, select Settings Summary.
2. Select the Brady Settings button.
3. Select the desired option for MV Sensor.

To program the Respiratory Sensor, use the following steps:

1. From the Summary tab, select Leads.
2. Select the Setup button.
3. Select the desired option for Respiration-related Trends.

CAUTION: To obtain an accurate MV baseline, the MV sensor will be calibrated automatically or can be calibrated manually. A new, manual calibration should be performed if the pulse generator is removed from the pocket following implant, such as during a lead repositioning procedure, or in cases where the MV baseline may have been affected by factors such as lead maturation, air entrapment in the pocket, pulse generator motion due to inadequate suturing, external defibrillation or cardioversion, or other patient complications (e.g., pneumothorax).

Respiratory Sensor

The following Respiratory Sensor information applies to INCEPTA and ENERGEN devices.

The Respiratory Sensor uses transthoracic impedance measurements to collect respiration-related data for use in generating the Respiratory Rate and ApneaScan trends.

CAUTION: Program the MV/Respiratory Sensor to Off during mechanical ventilation. Otherwise, the following may occur:

- Inappropriate MV sensor-driven rate
- Misleading respiration-based trending

Approximately every 50 ms (20 Hz), the pulse generator drives a current excitation waveform between the RV Coil electrode and Can. The application of the current between these electrodes creates an electrical field (modulated by respiration) across the thorax. During inspiration, the transthoracic impedance is high, and during expiration it is low. The pulse generator will detect the resulting voltage modulations between the RV Tip electrode and Can. Due to advanced filtering, breathing rates up to 65 breaths per minute are supported.

CAUTION: Any medical equipment, treatment, therapy, or diagnostic test that introduces electrical current into the patient has the potential to interfere with pulse generator function.

- External patient monitors (e.g., respiratory monitors, surface ECG monitors, hemodynamic monitors) may interfere with the pulse generator's impedance-based diagnostics (e.g., shock lead impedance measurements, Respiratory Rate trend). This interference may also result in accelerated pacing, possibly up to the maximum sensor-driven rate, when MV is programmed to On. To resolve suspected interactions with the MV sensor, deactivate the sensor either by

programming it to Off (no MV rate driving or MV sensor-based trending will occur), or Passive (no MV rate driving will occur). Alternatively, program the Brady Mode to a non-rate responsive mode (no MV rate driving will occur).

To resolve suspected interactions with Respiratory Sensor-based diagnostics, deactivate the pulse generator's Respiratory Sensor by programming it to Off.

NOTE: *The Respiratory Sensor signal does not cause an increase in heart rate.*

Consider the following when programming the sensor:

- Examine real-time EGMs before and after activating the sensor. The sensor signal can sometimes be observed on EGMs.

CAUTION: If MV/Respiratory Sensor signal artifacts are observed on EGMs, and the leads are otherwise shown to be performing appropriately, consider programming the sensor to Off to prevent oversensing.

- Program the sensor to Off if you detect or suspect any loss of lead integrity.

The pulse generator may temporarily suspend the sensor in the following circumstances:

- Detection of 3 fast intervals on the RV sense channel (when Tachy Mode is set to Monitor Only or Monitor + Therapy)—The pulse generator immediately suspends the sensor. It is turned on again after 1 hour unless there is a ventricular tachy detection in progress, in which case the device waits another hour to reevaluate.

CAUTION: For INCEPTA and ENERGEN devices, the Respiratory Sensor will not be suspended due to 3 fast intervals if the Tachy Mode is set to Off. Consider turning the Respiratory Sensor Off when Tachy Mode is Off to prevent potential oversensing and pauses in pacing.

NOTE: *If 3 fast ventricular beats are detected as a result of oversensing of the sensor signal, the patient may experience a short pause in pacing up to approximately twice the programmed LRL.*

- Excessive electrical noise levels—The pulse generator continuously monitors electrical noise levels. The sensor is temporarily suspended if noise is excessive, and is turned on again when noise decreases to an acceptable level.
- Loss of lead integrity—Lead impedances for the sensor are evaluated every 24 hours (separate from daily lead measurements). If either impedance measurement is out of range, the following occurs:
 - The pulse generator evaluates the lead impedance for a secondary vector driven from the RA Ring electrode to the Can, and measured from the RA Tip electrode to the Can. If this impedance measurement is in range, the sensor reverts to this secondary vector. If the lead impedance is also out of range with the secondary vector, the sensor is temporarily suspended until the next lead impedance evaluation in 24 hours.

NOTE: *If an RA lead is not used, the secondary vector is not available.*

- The pulse generator will continue to monitor lead impedance every 24 hours to determine if the sensor should be returned to the primary or secondary vector, or remain suspended. Acceptable lead impedance values are 200–2000 Ω for the tip to can and ring to can vectors and 20–200 Ω for the RV Coil to Can vector.

To program the Respiratory Sensor, use the following steps:

1. From the Settings tab on the main screen, select Settings Summary.
2. From the Settings Summary tab, select the Normal Settings button.
3. From the Normal Settings screen, select the Accelerometer button.
4. On the Accelerometer screen, select the desired option for Respiratory Sensor.

POST IMPLANT FEATURES

Patient Triggered Monitor (PTM)

This feature is available in AUTOGEN, DYNAGEN, INOGEN, ORIGEN, INCEPTA, ENERGEN, PUNCTUA, and COGNIS devices.

Patient Triggered Monitor allows the patient to trigger the storage of EGMs, intervals, and annotated marker data during a symptomatic episode by placing a magnet over the device. Instruct the patient to place the magnet on the device briefly and one time only.

Patient Triggered Monitor is enabled by selecting Store EGM as the desired Magnet Response. This can be found in the Magnet and Beeper section on the V-Tachy Therapy Setup screen.

When PTM is enabled, the patient can trigger data storage by holding a magnet over the device for at least 2 seconds. The device will store data for up to 2 minutes prior to and up to 1 minute after magnet application. The stored data include the episode number, rates at magnet application, and start time and date of magnet application. After one EGM is generated and stored, PTM is disabled. To store another EGM, the PTM feature must be re-enabled using the programmer. If 60 days elapse and the patient did not trigger data storage, PTM is automatically disabled.

When data are stored, the corresponding episode type is recorded as PTM in the Arrhythmia Logbook.

CAUTION: Use care when using Patient Triggered Monitor, because the following conditions will exist while it is enabled:

- All other magnet features, including inhibiting therapy, are disabled. The Magnet/Beeper feature will not indicate magnet position.
- Device longevity is impacted. To help reduce the longevity impact, PTM only allows storage of one episode, and PTM is automatically disabled after 60 days if data storage was never triggered.
- Once the EGM is stored (or 60 days elapses), PTM is disabled and the device Magnet Response automatically will be set to Inhibit Therapy. However, the pulse generator will not inhibit therapy until the magnet is removed for 3 seconds and placed on the device again.

To program the Patient Triggered Monitor feature, follow these steps:

1. From the Settings tab on the main screen, select Settings Summary.
2. From the Settings Summary tab, select Ventricular Tachy Therapy.
3. From Ventricular Tachy Therapy, select the V-Tachy Therapy Setup details button.
4. Program the Magnet Response to Store EGM.

5. Determine if the patient is capable of activating this feature prior to being given the magnet and prior to enabling Patient Triggered Monitor. Remind the patient to avoid strong magnetic fields so the feature is not inadvertently triggered.
6. Consider having the patient initiate a stored EGM at the time Patient Triggered Monitor is enabled to assist with patient education and feature validation. Verify the activation of the feature on the Arrhythmia Logbook screen.

WARNING: If desired, ensure that Patient Triggered Monitor is enabled prior to sending the patient home by confirming the Magnet Response is programmed to Store EGM. If the feature is inadvertently left in the Inhibit Therapy setting, the patient could potentially disable tachyarrhythmia detection and therapy.

WARNING: Once the Patient Triggered Monitor feature has been triggered by the magnet and an EGM has been stored, or after 60 days have elapsed from the day that Store EGM was enabled, the Magnet Response programming automatically will be set to Inhibit Therapy. When this happens, the patient should not apply the magnet because tachyarrhythmia therapy could be inhibited.

NOTE: *When the Magnet Response programming has automatically been set to Inhibit Therapy, magnet application will cause the device to emit beeping tones. Inform the patient that if they hear tones coming from their device after applying the magnet, they should remove the magnet.*

7. Patient Triggered Monitor can only be enabled for a 60-day period of time. To disable the feature within the 60-day time period, reprogram the Magnet Response to a setting other than Store EGM. When 60 days have passed since enabling Patient Triggered Monitor, the feature will automatically disable itself and the Magnet Response will revert to Inhibit Therapy. To re-enable the feature, repeat these steps.

For additional information, contact Boston Scientific using the information on the back cover.

Beeper Feature

This feature is available in AUTOGEN, DYNAGEN, INOGEN, ORIGEN, INCEPTA, ENERGEN, PUNCTUA, and COGNIS devices.

The pulse generator contains a beeper that emits audible tones to communicate status information. The Beeper includes both programmable and nonprogrammable features.

Programmable Features

The following Beeper features are programmable:

- **Beep During Capacitor Charge**—When programmed to On, regardless of the Tachy Mode, a warbling tone will sound continuously while the pulse generator is charging (except when charging during an auto capacitor re-form). The tone will continue until charging is complete. When this feature is programmed to Off, there is no audible indication that the pulse generator is charging. This feature is useful during EP testing.
- **Beep when Explant is Indicated**—When this feature is programmed to On, the pulse generator emits tones upon reaching Explant. The Explant indicator consists of 16 tones repeated every six hours after the pulse generator reaches Explant until the feature is turned off via the programmer. When this feature is programmed to Off, there is no audible indication of Explant.
- **Beep When Out-of-Range**—When this feature is programmed to On, the pulse generator emits tones when Daily Impedance values are out of range. It is separately programmable for each pacing lead impedance as well as shock impedance. The Out-of-Range indicator

consists of 16 tones repeated every six hours. When this feature is programmed to Off, there is no audible indication of Daily Impedance values.

Perform the following steps to program the Magnet and Beeper features:

Magnet and Beeper Response

1. Select the Settings tab.
2. From Ventricular Tachy, select the Therapy button.
3. Select the V-Tachy Therapy Setup button.
4. Enter the desired values.

Beep when Explant is Indicated

1. Select the Summary tab.
2. Select the Battery button.
3. From the Battery Status summary screen, select the Battery Detail button.
4. From the Battery Detail summary screen, select the desired value for Beep when Explant is Indicated.

Beep When Out-of-Range

1. Select the Summary tab.
2. Select the Leads button.
3. From the Leads Status summary screen, select the Setup tab.
4. Select the desired values for Beep When Out-of-Range.

NOTE: When the Magnet Response is programmed to Inhibit Therapy, magnet application will cause other types of beeping tones to be emitted, depending on the device mode. Refer to "Magnet Feature" on page 6-24 for more information.

Nonprogrammable Features

The following Beeper features are nonprogrammable:

- Battery capacity depleted—Regardless of whether Beep when Explant Is Indicated is programmed to On or Off, once the battery capacity is depleted, the pulse generator will emit the explant indicator tones
- Fault code tones—For certain fault codes or when Safety Mode is entered, the pulse generator will beep 16 times every 6 hours.

NOTE: Beeping tones may emit under nonprogrammable scenarios in response to device self-diagnostic testing. Advise patients to have their pulse generator checked whenever they hear tones coming from the device.

Configure Beeper Settings (post-MRI):

The Beeper will no longer be usable following an MRI scan. Coming in contact with the strong magnetic field of an MRI scanner causes a permanent loss of the Beeper volume. This cannot be

recovered, even after leaving the MR scan environment and exiting MRI Protection Mode. The system proactively disables the programmable and non-programmable Beeper features when MRI Protection Mode is programmed. The Beeper will remain Off upon exiting MRI Protection Mode. Upon interrogation, a notification will be provided on the Summary dialog that the Beeper is disabled due to MRI Protection Mode usage. After exit from MRI Protection Mode, the Beeper can be reenabled using the Configure Beeper Settings option if desired. After reenabling the Beeper, ensure it is still audible by checking the audible tones using the magnet. If the Beeper is inaudible, reprogram the Beeper to Off.

WARNING: The Beeper will no longer be usable following an MRI scan. Coming in contact with the strong magnetic field of an MRI scanner causes a permanent loss of the Beeper volume. This cannot be recovered, even after leaving the MR scan environment and exiting MRI Protection Mode. Before an MRI procedure is performed, a physician and patient should weigh the benefit of the MR procedure against the risk of losing the Beeper. It is strongly recommended that patients are followed on LATITUDE NXT after an MRI scan if they are not already. Otherwise, an in-clinic follow-up schedule of every three months is strongly recommended to monitor device performance.

The Configure Beeper Settings option will only be available after the device is programmed into MRI Protection Mode. When the Beeper is programmed back On, all programmable and non-programmable Beeper features will be reverted to their nominal values ("Magnet and Beeper Functions PgmOp" on page A-11).

Perform the following steps to program the Configure Beeper Settings:

1. Select the Settings tab.
2. Select the Beeper tab.
3. Select the desired value for Beeper.
4. After re-enabling the Beeper, ensure it is still audible by placing a magnet over the device and listening for beeps. If the Beeper is audible, leave the Beeper On. If the Beeper is not audible, program the Beeper to Off.

For additional information regarding the Beeper, refer to the ImageReady MR Conditional Defibrillation System MRI Technical Guide or contact Boston Scientific using the information on the back cover.

Magnet Feature

This feature is available in AUTOGEN, DYNAGEN, INOGEN, ORIGEN, INCEPTA, ENERGEN, PUNCTUA, and COGNIS devices.

The magnet feature allows certain device functions to be triggered when a magnet is placed in close proximity to the pulse generator (Figure 6-6 Proper position of magnet Model 6860 to activate the pulse generator magnet feature on page 6-25).

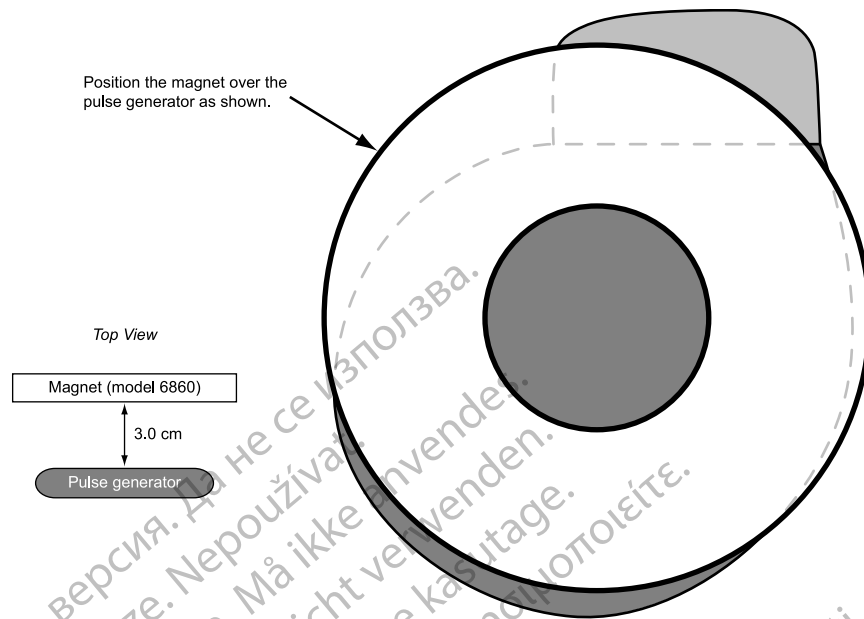

Figure 6-6. Proper position of magnet Model 6860 to activate the pulse generator magnet feature

The pulse generator Magnet Response settings can be programmed to control the behavior of the pulse generator when a magnet is detected. The Magnet Response settings are located in the Magnet and Beeper section of the V-Tachy Therapy Setup screen.

The following Magnet Response settings are available:

- Off—no response
- Store EGM—patient monitoring data will be stored
- Inhibit Therapy—therapy will be stopped

Off

When the Magnet Response is programmed to Off, application of the magnet will have no effect on the pulse generator.

Store EGM

When the Magnet Response is programmed to Store EGM, application of the magnet will activate the Patient Triggered Monitor functionality ("Patient Triggered Monitor" on page 6-21).

Inhibit Therapy

When the Magnet Response is programmed to Inhibit Therapy, application of the magnet will inhibit and/or divert charging for a shock, divert a shock that is about to be delivered, or inhibit and/or divert further ATP therapy.

When Magnet Response is programmed to Inhibit Therapy, initiation of tachyarrhythmia therapy and arrhythmia induction is inhibited any time the magnet is properly positioned over the pulse generator. The tachyarrhythmia detection process continues, but therapy or induction cannot be triggered. When a magnet is placed over the pulse generator, the following will occur:

- If the Tachy Mode is Monitor + Therapy or Off when the magnet is applied, the Tachy Mode changes temporarily to Monitor Only mode and will remain in Monitor Only mode as long as the magnet is applied. Three seconds after the magnet is removed, the mode will return to the previously programmed mode.

- If the pulse generator is charging to deliver shock therapy when the magnet is applied, the charging continues but is then terminated within one to two seconds of magnet application, and the charge is diverted. (This delay occurs in case the magnet is inadvertently passed over the device when therapy inhibition is not desired.) The pulse generator remains in temporary Monitor Only mode while the magnet is applied. No further therapy is initiated until the magnet is removed; however, detection will continue.
- If charging is complete or completes within the 1–2 second delay period, holding the magnet over the pulse generator for more than two seconds will divert the shock. (If the magnet is removed during the delay period, the shock could still be delivered.) Shocks will not be delivered with the magnet in place.
- If the pulse generator is initiating fibrillation induction or ATP pulses, it terminates the delivery after one to two seconds of magnet application. No further induction or ATP pulse sequences are initiated until the magnet is removed.
- If the Tachy Mode is Monitor Only or Off, magnet application will produce a constant tone to indicate that the device is in a non-therapy mode.
- If the Tachy Mode is Monitor + Therapy, magnet application will cause the pulse generator to beep once per second to indicate that the device is in a therapy mode.
- If the pulse generator is in Electrocautery Protection Mode, magnet application will produce beeping consistent with whichever Tachy Mode was active when the pulse generator was placed into Electrocautery Protection Mode. For example, if Electrocautery Protection Mode was enabled when the Tachy Mode was set to Monitor + Therapy, magnet application will cause the pulse generator to beep once per second.

NOTE: *If tachy detection occurs while the magnet is in place, detailed therapy history will indicate that therapy was not delivered because the device was in Monitor Only mode.*

NOTE: *The magnet feature is suspended when the pulse generator is in MRI Protection Mode.*

ELECTROPHYSIOLOGIC TESTING

CHAPTER 7

This chapter contains the following topics:

- “EP Test Features” on page 7-2
- “Induction Methods” on page 7-4
- “Commanded Therapy Methods” on page 7-8

Остаряла версия. Да не се използва.
Zastaralá verze. Nepoužívat.
Forældet version. Må ikke anvendes.
Version überholt. Nicht verwenden.
Aegunud versioón. Árgæ kasutage.
Παλιά έκδοση. Μην την χρησιμοποιείτε.
Outdated version. Do not use.
Versión obsoleta. No utilizar.
Zastarjela verzija. Nemojte upotrebljavati.
Úreilt útgáfa. Notið ekki.
Versione obsoleta. Non utilizzare.
Pasenusi versija. Neizmantot.
Elavult verzió. Ne használja!
Dit is een verouderde versie. Niet gebruiken.
Utdatert versjon. Skal ikke brukes.
Wersja przeterminowana. Nie używać.
Versão obsoleta. Não utilize.
Versiune expirată. A nu se utiliza.
Zastaraná verzia. Nepoužívať.
Vanhentunut versio. Älä käytä.
Föråldrad version. Använd ej.
Güncel olmayan sürüm. Kullanmayın.

EP TEST FEATURES

Electrophysiologic (EP) Testing features enable you to induce and terminate arrhythmias noninvasively in order to monitor and test the effectiveness of selected detection criteria and therapies. The EP Test features can be used in conjunction with the ECG display so that real-time traces may be viewed. The status of the pulse generator/patient interaction is also displayed.

WARNING: Always have external defibrillation equipment available during implant and electrophysiologic testing. If not terminated in a timely fashion, an induced ventricular tachyarrhythmia can result in the patient's death.

The features allowing noninvasive EP testing of arrhythmias include the following:

- V Fib induction
- Shock on T induction
- Programmed electrical stimulation (PES) induction/termination
- 50 Hz/Manual Burst pacing induction/termination
- Commanded Shock therapy
- Commanded ATP therapy

Temporary EP Mode

Temporary EP Mode allows you to program the device mode to a temporary value for EP test delivery, and ensures that the normal device mode remains unchanged.

EP Test Screen

The EP Test screen displays the real-time status of the detection and therapy process of the pulse generator when telemetry communication is occurring. Viewing this display allows you to induce and test either a programmed detection/therapy prescription or optional therapies while monitoring the pulse generator's progress.

Refer to the EP Test screen (Figure 7–1 EP Test Screen on page 7-2):

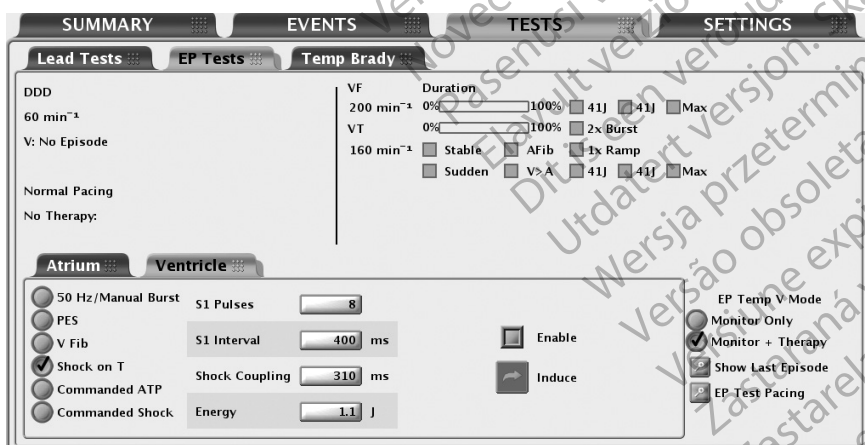

Figure 7–1. EP Test Screen

The screen provides the following information:

- Status messages indicate detection and therapy status and are described below:

- Ventricular episode status—if an episode is occurring, the duration of the episode is displayed. (If it is greater than 10 minutes, then it is displayed as > 10:00 m:s).
- Ventricular detection status—if an episode is occurring, it indicates whether ventricular detection is in Initial Detection, Redetection, or the zone in which that detection is met. If no episode is occurring, the programmer will also display the time (in minutes) since the last ventricular therapy (up to 10 minutes).
- Brady pacing and SRD status.
- The type of therapy initiated and the zone.
- The status of the therapy such as In Progress, Diverted, or Delivered.
- Duration timer—Progression of the duration timer is graphically displayed using a scale. The bar in the scale moves from left to right to show the percent complete of programmed duration. When duration is expired and therapy delivery begins, the bar is removed.
- Detection status—The status for each programmed detection enhancement is displayed. When enhancement criteria are met, a mark appears in the adjacent box.
- Therapy prescriptions—Only those therapy prescriptions that are programmed are displayed. As each therapy is delivered, a check mark or number will appear in the box adjacent to the respective therapy. ATP therapies indicate the scheme type as well as the programmed number of bursts in the scheme. A number will appear and increment (1, 2, etc.) in the ATP therapy box each time an ATP burst is delivered. Shock therapies indicate the programmed energy level for the programmable shocks. A number will appear and increment (1, 2, etc.) in the Max box each time a maximum-energy shock is delivered.

Follow the steps below to perform EP Test functions:

1. Select the Tests tab, then select the EP Tests tab.
2. Establish telemetry communication. Telemetry communication between the programmer and the pulse generator should be maintained throughout all EP test procedures.
3. Set Backup Pacing and EP Test Pacing Outputs as desired.
4. Program the EP Temp V Mode appropriate to the EP Test method (Table 7–1 EP Temp V Mode for EP Test Functions on page 7-3).

Table 7–1. EP Temp V Mode for EP Test Functions

EP Test Method ^a	EP Temp V Mode		
	Monitor + Therapy ^d	Monitor Only ^e	Off
50 Hz/Manual Burst ^b	X		
PES ^b	X		
V Fib ^c	X		
Shock on T ^c	X		
Commanded ATP ^c		X	
Commanded Shock ^c	X	X	

- a. EP functions cannot be performed if the pulse generator is in Storage Mode.
- b. Available method for both atrial and ventricular induction.
- c. Available method only for ventricular induction.
- d. The Ventricular Tachy Mode must be programmed to Monitor + Therapy.
- e. The Ventricular Tachy Mode must be programmed to Monitor Only or Monitor + Therapy.

INDUCTION METHODS

Each EP Test method available from the EP Test screen is described below with instructions. During any type of induction/termination, the pulse generator performs no other activity until the test has ceased, at which time the programmed mode will take effect and the pulse generator will respond accordingly.

Consider the following information when using these methods:

- Ventricular PES, Shock on T wave, and Ventricular ATP are BiV
- Ventricular Manual Burst and 50 Hz Burst are RV Only
- All inductions and tachycardia therapy delivery are inhibited when a magnet is positioned over the pulse generator (if magnet response is set to Inhibit Therapy)
- Pacing pulses during induction are delivered at the programmed EP Test pacing parameters

VFib Induction

V Fib induction uses the shocking electrodes to stimulate the right ventricle at very fast rates.

The following settings are available to allow use of the minimum energy necessary for induction:

- V Fib Low delivers a stimulation waveform of 9 volts
- V Fib High delivers a stimulation waveform of 15 volts

Performing V Fib Induction

NOTE: *The patient should be sedated prior to delivery of fibrillation induction pulses. The large surface area of the shocking electrodes tends to stimulate the surrounding muscle and can be uncomfortable.*

1. Select the V Fib option. Buttons for each test and an Enable checkbox are displayed.
2. Select the Enable checkbox.
3. Select the desired Hold for Fib button to initiate delivery of the fibrillation induction train. The induction train is delivered up to 15 seconds as long as the button is held and the telemetry link is maintained.

During induction the pulse generator is automatically disabled from detecting, and automatically re-enabled following induction delivery. If V Fib induction is initiated during an episode, the end-of-episode is declared before the V Fib induction pulses are started. A new episode (with initial detection and therapy) can be declared after the V Fib induction is completed. Event markers and EGMs are interrupted during V Fib induction and will automatically restart following induction.

4. To stop the induction train, release the button (the button will become dimmed again).

For AUTOGEN, DYNAGEN, INOGEN, ORIGEN, INCEPTA, ENERGEN, and PUNCTUA devices, following the induction the pulse generator automatically restarts detection and Post-shock Pacing is activated.

For COGNIS devices, following the induction the pulse generator automatically restarts detection and normal pacing is activated.

5. To deliver another fibrillation induction, repeat these steps.

Shock on T Induction

A Shock on T wave induction method allows the device to deliver a drive train (up to 30 equally timed pacing pulses, or S1 pulses) through the ventricular pace/sense electrodes followed by shock delivery through the shocking electrodes (Figure 7–2 Shock on T induction drive train on page 7-5).

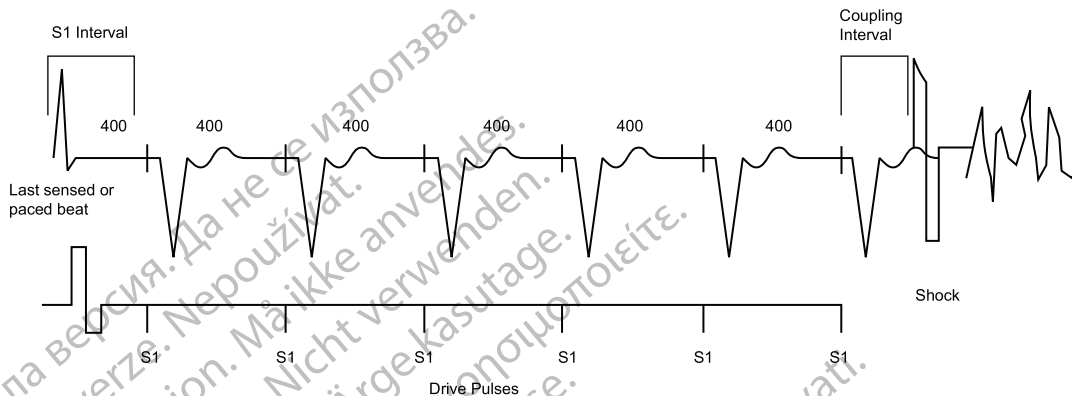

Figure 7–2. Shock on T induction drive train

The initial S1 pulse follows the last sensed or paced event at the S1 Interval. The shock is coupled to the last S1 pulse of the drive train.

Performing Shock on T Induction

1. Select the Shock on T option. The programmable induction parameters will be displayed.
2. Select the desired value for each parameter.
3. Select the Enable checkbox. The Induce button will no longer be dimmed.
4. Select the induce button to begin delivery of the drive train. The pulses are delivered in sequence until the programmed number of pulses is reached. Once induction is initiated, the drive train delivery will not stop if you interrupt telemetry communication. While telemetry is active, pressing the DIVERT THERAPY key will stop induction delivery.
5. Shock on T induction is complete when the drive train and shock are delivered, at which time the pulse generator automatically restarts detection.

For AUTOGEN, DYNAGEN, INOGEN, ORIGEN, INCEPTA, ENERGEN, and PUNCTUA devices, Post-shock Pacing is then activated.

For COGNIS devices, normal pacing is then activated.

NOTE: Prior to drive train delivery, tones will be heard indicating capacitor charging in preparation for shock delivery.

NOTE: The shock delivered during Shock on T induction does not increment episode or therapy counters.

Backup Ventricular Pacing During Atrial EP Testing

Backup biventricular pacing is available during atrial EP testing (PES, 50 Hz/Manual Burst) regardless of the programmed Normal or Post-therapy pacing modes.

NOTE: Backup Pacing is performed in VOO mode.

Program the backup pacing parameters by selecting the EP Test Pacing button. Backup Pacing parameters are independently programmable from the permanent pacing parameters. Backup Pacing can also be disabled by programming the Backup Pacing Mode to Off.

Programmed Electrical Stimulation (PES)

PES induction allows the pulse generator to deliver up to 30 equally timed pacing pulses (S1) followed by up to 4 premature stimuli (S2–S5) to induce or terminate arrhythmias. Drive pulses, or S1 pulses, are intended to capture and drive the heart at a rate slightly faster than the intrinsic rate. This ensures that the timing of the premature extra stimuli will be accurately coupled with the cardiac cycle (Figure 7–3 PES induction drive train on page 7-6).

The initial S1 pulse is coupled to the last sensed or paced beat at the S1 Interval. All pulses are delivered in XOO modes (where X is the chamber) at the programmed EP Test pacing parameters.

For Atrial PES, backup pacing parameters are provided.

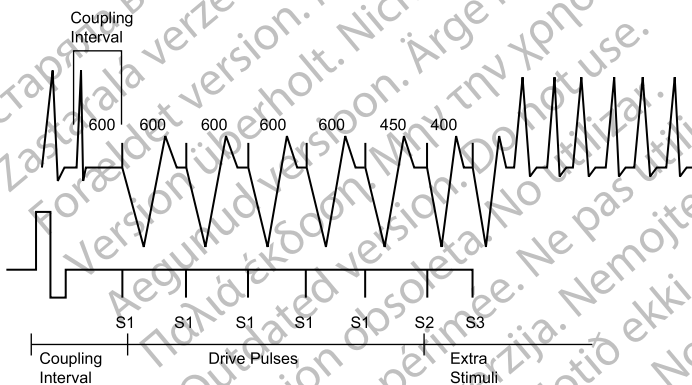

Figure 7–3. PES induction drive train

Performing PES Induction

1. Choose the Atrium or Ventricle tab, depending on which chamber you want to pace
2. Select the PES option. Buttons for the S1–S5 pulses and the corresponding burst cycle lengths are displayed
3. Select the desired value for the S1–S5 intervals (Figure 7–4 PES induction options on page 7-6). You can either select a value box for the desired S interval and choose a value from the box or use the plus or minus symbols to change the value visible in the value box.

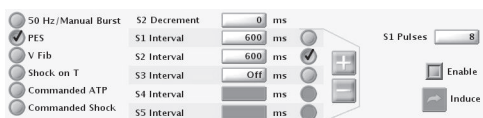

Figure 7–4. PES induction options

4. Select the Enable checkbox.
5. Select (do not hold) the Induce button to begin delivery of the drive train. When the programmed number of S1 pulses is delivered, the pulse generator will then deliver the programmed S2–S5 pulses. The pulses are delivered in sequence until a pulse is encountered that is set to Off (e.g., if S1 and S2 are set to 600 ms, and S3 is Off, then S3,

S4, and S5 will not be delivered). Once induction is initiated, the PES delivery will not stop if you interrupt telemetry communication. (While telemetry is active, pressing the DIVERT THERAPY key will stop induction delivery.)

6. PES induction is complete when the drive train and extra stimuli are delivered, at which time the pulse generator automatically restarts detection.

NOTE: Ensure the PES induction is complete before beginning another induction.

NOTE: When PES is used to terminate an arrhythmia that has been detected (and an episode declared), the episode is terminated when the PES is commanded regardless of whether it is successful or not. A new episode can be declared after the PES induction is completed. The PES itself is not recorded in therapy history; this may result in several episodes being counted in therapy history.

NOTE: Real-time EGMs and annotated event markers will continue to be displayed during the entire test sequence.

50 Hz/Manual Burst Pacing

50 Hz pacing and Manual Burst pacing are both used to induce or terminate arrhythmias when delivered to the desired chamber. Pacing parameters are programmable for Manual Burst but are fixed for 50 Hz pacing.

Manual Burst and 50 Hz pacing pulses are delivered in XOO mode (where X is the chamber) at the programmed EP Test pacing parameters. For Atrial Manual Burst and 50 Hz, backup pacing parameters are provided.

Performing Manual Burst Pacing

1. Choose the Atrium or Ventricle tab, depending on which chamber you want to pace.
2. Select the 50 Hz/Manual Burst option.
3. Select the desired value for the Burst Interval, Minimum, and Decrement. This indicates the cycle length of the intervals in the drive train.
4. Select the Enable checkbox.
5. To deliver the burst, select and hold the Hold for Burst button.

The ventricular Manual Burst will be delivered up to 30 seconds as long as the Hold for Burst button is held and the telemetry link is maintained.

The atrial Manual Burst will be delivered up to 45 seconds as long as the Hold for Burst button is held and the telemetry link is maintained.

The intervals will continue to be decremented until the Minimum interval is reached, then all further pulses will be at the Minimum interval.

6. To stop the burst delivery, release the Hold for Burst button. The Hold for Burst button will become dimmed again.
7. To deliver additional Manual Burst pacing, repeat these steps.

Performing 50 Hz Burst Pacing

1. Choose the Atrium or Ventricle tab, depending on which chamber you want to pace.

2. Select the 50 Hz/Manual Burst option.
3. Select the Enable checkbox.
4. To deliver the burst, select and hold the Hold for 50 Hz Burst button.

The ventricular 50 Hz Burst will be delivered up to 30 seconds as long as the Hold for Burst button is held and the telemetry link is maintained.

The atrial 50 Hz Burst will be delivered up to 45 seconds as long as the Hold for Burst button is held and the telemetry link is maintained.

NOTE: *During Hold for 50 Hz Burst pacing, the S1 Interval is automatically set to 20 ms and the Decrement to 0. These values will not be displayed on the screen.*

5. To stop the burst delivery, release the Hold for 50 Hz Burst button. The Hold for 50 Hz Burst button will become dimmed again.
6. To deliver additional 50 Hz Burst pacing, repeat these steps.

NOTE: *Real-time EGMs and annotated event markers will continue to be displayed during the entire test sequence.*

COMMANDED THERAPY METHODS

The commanded EP test methods, Commanded Shock and Commanded ATP, may be delivered independently of the programmed detection and therapy parameters. If the pulse generator is in the process of delivering therapy when a commanded method is initiated, the EP Test function overrides and aborts the therapy in process. If an episode is not in progress, then a Commanded Ventricular Episode will be recorded in the Arrhythmia Logbook. Commanded Shock and Commanded ATP delivery is inhibited when the DIVERT THERAPY key is pressed or when a magnet is positioned over the pulse generator, if it is programmed to Inhibit Therapy.

Commanded Shock

The Commanded Shock feature allows delivery of a shock with programmable Energy and Coupling Interval.

All Commanded Shocks are Committed and delivered R-Wave synchronously when the Coupling Interval is programmed to Sync. Shock Waveform and Polarity are identical to detection-initiated shocks but a programmed Coupling Interval may be specified. The Coupling Interval is initiated at the point where the shock would have been delivered in Sync mode, but is instead delivered at the programmed Coupling Interval. Following any Commanded Shock delivery, Post-Shock Redetection is used and Post-shock Pacing is activated.

Performing Commanded Shock Delivery

1. Select the Commanded Shock option.
2. Select the desired values for the Coupling Interval and Shock Energy.
3. Select the Enable checkbox. The Deliver Shock button will become available.
4. Select the Deliver Shock button to initiate shock delivery. The Commanded Shock is recorded in therapy history.
5. To deliver subsequent shocks, repeat these steps.

Commanded ATP

Commanded ATP allows you to manually deliver ATP schemes, independent of the programmed detection and therapy parameters. You can configure the Commanded ATP by either selecting the type of ATP scheme or by programming ATP parameters on the Details screen in order to deliver Commanded ATP.

The EP Temp V Mode must be programmed to Monitor Only to ensure the Commanded ATP does not interfere with detection-initiated ATP.

Performing Commanded ATP

1. If the pulse generator Ventricular Tachy Mode is not currently programmed to Monitor Only, select the Monitor Only EP Temp V Mode option.
2. Select the type of ATP scheme and select the value for Number of Bursts.
3. Select the Start Ventricular ATP button to initiate the first burst in the selected ATP scheme. The Bursts Remaining counter will decrement as each burst is completed.
4. Select the Continue button for each additional burst delivery desired. If all bursts in a scheme have been delivered, the Bursts Remaining counter will return to the initial count, and the Continue button will be dimmed.
5. Other ATP schemes may be selected at any time; select the desired scheme and repeat the above sequence. The Commanded ATP is recorded as a physician-commanded therapy counter and displayed on the counters screen.
6. After using Commanded ATP, remember to program the EP Temp V Mode to Monitor + Therapy or leave the screen so that the EP Temp V Mode is ended and the permanent Tachy Mode is resumed.

NOTE: If any button other than the Continue button is selected during delivery of a Commanded ATP scheme, the scheme will be reset and the Bursts Remaining box will be restored to its initial value. The Start Ventricular ATP button must be reselected to initiate the scheme again.

Остаряла версия. Да не се използва.
Zastaralá verze. Nepoužívat.
Forældet version. Må ikke anvendes.
Version überholt. Nicht verwenden.
Aegunud versioón. Äрге kasutage.
Παλιά έκδοση. Μην την χρησιμοποιείτε.
Outdated version. Do not use.
Versión obsoleta. Ne utilizar.
Zastarjela verzija. Nemojte upotrebljavati.
Úreilt útgáfa. Notið ekki.
Versione obsoleta. Non utilizzare.
Pasenusi versija. Nenaudokite.
Elavult verzió. Ne használja!
Dit is een verouderde versie. Niet gebruiken.
Wersja przeterminowana. Nie używać.
Versão obsoleta. Não utilize.
Versiune expirată. A nu se utiliza.
Zastaraná verzia. Nepoužívať.
Vanhentunut versio. Älä käytä.
Föråldrad version. Använd ej.
Güncel olmayan sürüm. Kullanmayın.

PROGRAMMABLE OPTIONS

APPENDIX A

Table A–1. ZIP Telemetry settings

Parameter	Programmable Values	Nominal ^a
Communication Mode	Enable use of ZIP telemetry (May require limited use of wand); Use wand for all telemetry	Enable use of ZIP telemetry (May require limited use of wand)

a. If the Communication Mode is selected via the Utilities button on the PRM Startup screen, the Nominal setting within the ZOOMVIEW Programmer software application will correspond to the value chosen on the Startup screen.

Table A–2. Tachy Mode parameter

Parameter	Programmable Values	Nominal
Tachy Mode	Off; Monitor Only; Monitor + Therapy; Enable Electrocautery Protection; Enable MRI Protection ^a	Storage

a. Available in models with the MRI Protection Mode feature.

Table A–3. Ventricular Zones parameter

Parameter	Programmable Values	Nominal
Ventricular Zones	1; 2; 3	2

Table A–4. Detection parameters for 1-zone, 2-zone, and 3-zone configurations

Parameter	VT-1 Zone	VT Zone	VF Zone	Nominal
Rate ^a (min ⁻¹) 3 zones (intervals in ms)	90; 95; ...; 200 (667–300)	110; 115; ...; 210 (545–286); 220 (273)	130; 135; ...; 210 (462–286); 220; 230; 240; 250 (273–240)	140 (Tolerance ± 5 ms) for VT-1 Zone 160 (Tolerance ± 5 ms) for VT Zone 200 (Tolerance ± 5 ms) for VF Zone
Rate ^a (min ⁻¹) 2 zones (intervals in ms)	--	90; 95; ...; 210 (667–286); 220 (273)	110; 115; ...; 210 (545–286); 220; 230; 240; 250 (273–240)	160 (Tolerance ± 5 ms) for VT Zone 200 (Tolerance ± 5 ms) for VF Zone
Rate ^a (min ⁻¹) 1 zone (intervals in ms)	--	--	90; 95; ...; 210 (667–286); 220 (273)	200 (Tolerance ± 5 ms)
Initial Duration ^b (sec) 3 zones	1.0; 1.5; ...; 5.0; 6.0; 7.0; ...; 15.0; 20.0; 25.0; ...; 60.0	1.0; 1.5; ...; 5.0; 6.0; 7.0; ...; 15.0; 20.0; 25.0; 30.0	1.0; 1.5; ...; 5.0; 6.0; 7.0; ...; 15.0	2.5 (Tolerance ± 1 cardiac cycle) for VT-1 Zone 2.5 (Tolerance ± 1 cardiac cycle) for VT Zone 1.0 (Tolerance ± 1 cardiac cycle) for VF Zone
Initial Duration ^b (sec) 2 zones	--	1.0; 1.5; ...; 5.0; 6.0; 7.0; ...; 15.0; 20.0; 25.0; 30.0	1.0; 1.5; ...; 5.0; 6.0; 7.0; ...; 15.0	2.5 (Tolerance ± 1 cardiac cycle) for VT Zone 1.0 (Tolerance ± 1 cardiac cycle) for VF Zone
Initial Duration (sec) 1 zone	--	--	1.0; 1.5; ...; 5.0; 6.0; 7.0; ...; 15.0	1.0 (Tolerance ± 1 cardiac cycle)
Redetection Duration ^b (sec) 3 zones	1.0; 1.5; ...; 5.0; 6.0; 7.0; ...; 15.0	1.0; 1.5; ...; 5.0; 6.0; 7.0; ...; 15.0	1.0 (nonprogrammable)	1.0 (Tolerance ± 1 cardiac cycle) for all zones
Redetection Duration (sec) 2 zones	--	1.0; 1.5; ...; 5.0; 6.0; 7.0; ...; 15.0	1.0 (nonprogrammable)	1.0 (Tolerance ± 1 cardiac cycle) for all zones

Table A-4. Detection parameters for 1-zone, 2-zone, and 3-zone configurations (continued)

Parameter	VT-1 Zone	VT Zone	VF Zone	Nominal
Redetection Duration (sec) 1 zone	--	--	1.0 (nonprogrammable)	1.0 (Tolerance ± 1 cardiac cycle)
Post-shock Duration ^b (sec) 3 zones	1.0; 1.5; ...; 5.0; 6.0; 7.0; ...; 15.0; 20.0; 25.0; ...; 60.0	1.0; 1.5; ...; 5.0; 6.0; 7.0; ...; 15.0; 20.0; 25.0; 30.0	1.0 (nonprogrammable)	1.0 (Tolerance ± 1 cardiac cycle) for all zones
Post-shock Duration (sec) 2 zones	--	1.0; 1.5; ...; 5.0; 6.0; 7.0; ...; 15.0; 20.0; 25.0; 30.0	1.0 (nonprogrammable)	1.0 (Tolerance ± 1 cardiac cycle) for all zones
Post-shock Duration (sec) 1 zone	--	--	1.0 (nonprogrammable)	1.0 (Tolerance ± 1 cardiac cycle)

- a. The Rate difference between each tachy zone must be at least 20 min⁻¹. The lowest Tachy Rate Threshold must be ≥ 5 min⁻¹ higher than the Maximum Tracking Rate, Maximum Sensor Rate, and the Maximum Pacing Rate; and the lowest Tachy Rate Threshold must be ≥ 15 min⁻¹ higher than the Lower Rate Limit.
- b. The Duration in a zone must be equal to or greater than the Duration in the next highest zone.

Table A-5. Ventricular Detection Enhancement Type for 2-zone and 3-zone configurations

Parameter	Programmable Values	Nominal
Detection Enhancement Type	Off; Rhythm ID ^a ; Onset/Stability	Onset/Stability

- a. Available in models with the Rhythm ID feature.

Table A-6. Onset/Stability detection enhancement parameters for 2-zone and 3-zone configurations

Parameter	VT-1 Zone	VT Zone	VF Zone	Nominal
V Rate > A Rate 3 zones ^a	Off; On	--	--	On
V Rate > A Rate 2 zones	--	Off; On	--	On
AFib Rate Threshold (min ⁻¹) 3 zones ^{a b}	Off; 100; 110; ...; 300	--	--	170 (Tolerance ± 5 ms)
AFib Rate Threshold (min ⁻¹) 2 zones ^b	--	Off; 100; 110; ...; 300	--	170 (Tolerance ± 5 ms)
Stability (ms) 3 zones ^a	Off; 6; 8; ...; 32; 35; 40; ...; 60; 70; 80; ...; 120	--	--	20 (Tolerance ± 5 ms)
Stability (ms) 2 zones	--	Off; 6; 8; ...; 32; 35; 40; ...; 60; 70; 80; ...; 120	--	20 (Tolerance ± 5 ms)
Shock If Unstable (ms) 3 zones	--	Off; 6; 8; ...; 32; 35; 40; ...; 60; 70; 80; ...; 120	--	30 (Tolerance ± 5 ms)
Shock If Unstable (ms) 2 zones	--	Off; 6; 8; ...; 32; 35; 40; ...; 60; 70; 80; ...; 120	--	Off (Tolerance ± 5 ms)
Onset (% or ms) 3 zones ^a	Off; 9; 12; 16; 19; ...; 37; 41; 44; 47; 50% or 50; 60; ...; 250 ms	--	--	9% (Tolerance ± 5 ms)
Onset (% or ms) 2 zones	--	Off; 9; 12; 16; 19; ...; 37; 41; 44; 47; 50% or 50; 60; ...; 250 ms	--	9% (Tolerance ± 5 ms)
Stability And/Or Onset 3 zones ^a	And; Or	--	--	And
Stability And/Or Onset 2 zones	--	And; Or	--	And
Sustained Rate Duration (min:sec) 3 zones ^a	Off; 00:10; 00:15; ...; 00:55; 01:00; 01:15; ...; 02:00; 02:30; 03:00; ...; 10:00; 15:00; 20:00; ...; 60:00	--	--	03:00 (Tolerance ± 1 cardiac cycle)
Sustained Rate Duration (min:sec) 2 zones	--	Off; 00:10; 00:15; ...; 00:55; 01:00; 01:15; ...; 02:00; 02:30; 03:00; ...;	--	03:00 (Tolerance ± 1 cardiac cycle)

Table A-6. Onset/Stability detection enhancement parameters for 2-zone and 3-zone configurations (continued)

Parameter	VT-1 Zone	VT Zone	VF Zone	Nominal
		10:00; 15:00; 20:00; ...; 60:00		
Detection Enhancement 3 zones	Off; On	Off; On	--	On (VT-1); Off (VT)
Detection Enhancement 2 zones	--	Off; On	--	On
Atrial Tachyarrhythmia Discrimination 3 zones ^a	Off; On	--	--	On
Atrial Tachyarrhythmia Discrimination 2 zones	--	Off; On	--	On
Sinus Tachycardia Discrimination 3 zones ^a	Off; On	--	--	On
Sinus Tachycardia Discrimination 2 zones	--	Off; On	--	On
Polymorphic VT Discrimination 3 zones	--	Off; On	--	On
Polymorphic VT Discrimination 2 zones	--	Off; On	--	Off

- a. If all VT-1 therapy is programmed to Off, detection enhancements will apply in the VT zone, not the VT-1 zone.
 b. All of the AFib Rate Thresholds are linked to the ATR Trigger Rate and Atrial Flutter Response Rate. If any one of these rates is reprogrammed, the others will automatically change to the same value.

Table A-7. Rhythm ID detection enhancement parameters for 2-zone and 3-zone configurations

Parameter	VT-1 Zone	VT Zone	VF Zone	Nominal
Initial Detection Enhancement 3 zones	Off; On	Off; On	--	On (VT-1); Off (VT)
Initial Detection Enhancement 2 zones	--	Off; On	--	Off
Sustained Rate Duration (min:sec) 3 zones	Off; 00:10; 00:15; ...; 01:00; 01:15; ...; 02:00; 02:30; ...; 10:00; 15:00; ...; 60:00	Off; 00:10; 00:15; ...; 01:00; 01:15; ...; 02:00; 02:30; ...; 10:00; 15:00; ...; 60:00	--	03:00 (VT-1 and VT) (Tolerance \pm 1 cardiac cycle)
Sustained Rate Duration (min:sec) 2 zones		Off; 00:10; 00:15; ...; 01:00; 01:15; ...; 02:00; 02:30; ...; 10:00; 15:00; ...; 60:00		03:00 (Tolerance \pm 1 cardiac cycle)
Passive Method 3 zones (one value for all zones)	Off; On	Off; On	--	On
Passive Method 2 zones	--	Off; On	--	On
Active Method 3 zones (one value for all zones)	Off; On	Off; On	--	On
Active Method 2 zones	--	Off; On	--	On
RhythmMatch Threshold (%) 3 zones (one value for all zones)	70; 71; ...; 96	70; 71; ...; 96	--	94
RhythmMatch Threshold (%) 2 zones	--	70; 71; ...; 96	--	94
Temporary LRL (min ⁻¹) 3 zones (one value for all zones)	Use Normal Brady LRL; 30; 35; ...; 105	Use Normal Brady LRL; 30; 35; ...; 105	--	Use Normal Brady LRL (Tolerance \pm 5 ms)
Temporary LRL (min ⁻¹) 2 zones	--	Use Normal Brady LRL; 30; 35; ...; 105	--	Use Normal Brady LRL (Tolerance \pm 5 ms)
Atrial Tachy Discrimination 3 zones (one value for all zones)	Off; On	Off; On	--	On

Table A-7. Rhythm ID detection enhancement parameters for 2-zone and 3-zone configurations (continued)

Parameter	VT-1 Zone	VT Zone	VF Zone	Nominal
Atrial Tachy Discrimination 2 zones	--	Off; On	--	On
AFib Rate Threshold (min ⁻¹) 3 zones (one value for all zones) ^{a b}	100; 110; ...; 300	100; 110; ...; 300	--	170 (Tolerance ± 5 ms)
AFib Rate Threshold (min ⁻¹) 2 zones ^{a b}	--	100; 110; ...; 300	--	170 (Tolerance ± 5 ms)
Stability (ms) 3 zones (one value for all zones) ^a	6; 8; ...; 32; 35; 40; ...; 60; 70; ...; 120	6; 8; ...; 32; 35; 40; ...; 60; 70; ...; 120	--	20 (Tolerance ± 5 ms)
Stability (ms) 2 zones ^a	--	6; 8; ...; 32; 35; 40; ...; 60; 70; ...; 120	--	20 (Tolerance ± 5 ms)

- a. This parameter is used in initial detection and Post-shock Detection. Changing the value for initial detection will change the value for Post-Therapy Brady.
- b. All of the AFib Rate Thresholds are linked to the ATR Trigger Rate and Atrial Flutter Response Rate. If any one of these rates is reprogrammed, the others will automatically change to the same value.

Table A-8. Post-shock Onset/Stability detection enhancement parameters for 2-zone and 3-zone configurations

Parameter	VT-1 Zone	VT Zone	VF Zone	Nominal
Post-shock V Rate > A Rate 3 zones ^a	Off; On	--	--	On
Post-shock V Rate > A Rate 2 zones	--	Off; On	--	On
Post-shock AFib Rate Threshold (min ⁻¹) 3 zones ^{a b}	Off; 100; 110; ...; 300	--	--	170 (Tolerance ± 5 ms)
Post-shock AFib Rate Threshold (min ⁻¹) 2 zones ^b	--	Off; 100; 110; ...; 300	--	170 (Tolerance ± 5 ms)
Post-shock Stability (ms) 3 zones ^a	Off; 6; 8; ...; 32; 35; 40; ...; 60; 70; 80; ...; 120	--	--	20 (Tolerance ± 5 ms)
Post-shock Stability (ms) 2 zones	--	Off; 6; 8; ...; 32; 35; 40; ...; 60; 70; 80; ...; 120	--	20 (Tolerance ± 5 ms)
Post-shock Sustained Rate Duration (min:sec) 3 zones ^a	Off; 00:10; 00:15; ...; 00:55; 01:00; 01:15; ...; 02:00; 02:30; 03:00; ...; 10:00; 15:00; 20:00; ...; 60:00	--	--	00:15 (Tolerance ± 1 cardiac cycle)
Post-shock Sustained Rate Duration (min:sec) 2 zones	--	Off; 00:10; 00:15; ...; 00:55; 01:00; 01:15; ...; 02:00; 02:30; 03:00; ...; 10:00; 15:00; 20:00; ...; 60:00	--	00:15 (Tolerance ± 1 cardiac cycle)

- a. If all VT-1 therapy is programmed to Off, detection enhancements will apply in the VT zone, not the VT-1 zone.
- b. All of the AFib Rate Thresholds are linked to the ATR Trigger Rate and Atrial Flutter Response Rate. If any one of these rates is reprogrammed, the others will automatically change to the same value.

Table A-9. Post-shock Rhythm ID detection enhancement parameters for 2-zone and 3-zone configurations

Parameter	VT-1 Zone	VT Zone	VF Zone	Nominal
Post Shock Detection Enhancement 3 zones	Off; On	Off; On	--	Off
Post Shock Detection Enhancement 2 zones	--	Off; On	--	Off
Post Shock Sustained Rate Duration (min:sec) 3 zones	Off; 00:10; 00:15; ...; 00:55; 01:00; 01:15; ...; 02:00; 02:30; ...; 10:00; 15:00; ...; 60:00	Off; 00:10; 00:15; ...; 00:55; 01:00; 01:15; ...; 02:00; 02:30; ...; 10:00; 15:00; ...; 60:00	--	0:15 (Tolerance ± 1 cardiac cycle)

Table A-9. Post-shock Rhythm ID detection enhancement parameters for 2-zone and 3-zone configurations (continued)

Parameter	VT-1 Zone	VT Zone	VF Zone	Nominal
Post Shock Sustained Rate Duration (min:sec) 2 zones	--	Off; 00:10; 00:15; ...; 00:55; 01:00; 01:15; ...; 02:00; 02:30; ...; 10:00; 15:00; ...; 60:00	--	0:15 (Tolerance \pm 1 cardiac cycle)
AFib Rate Threshold (min ⁻¹) 3 zones (one value for all zones) ^{a b}	100; 110; ...; 300	100; 110; ...; 300	--	170 (Tolerance \pm 5 ms)
AFib Rate Threshold (min ⁻¹) 2 zones ^{a b}	--	100; 110; ...; 300	--	170 (Tolerance \pm 5 ms)
Stability (ms) 3 zones (one value for all zones) ^a	6; 8; ...; 32; 35; 40; ...; 60; 70; ...; 120	6; 8; ...; 32; 35; 40; ...; 60; 70; ...; 120	--	20 (Tolerance \pm 5 ms)
Stability (ms) 2 zones ^a	--	6; 8; ...; 32; 35; 40; ...; 60; 70; ...; 120	--	20 (Tolerance \pm 5 ms)

- a. This parameter is used in initial detection and Post-shock Detection. Changing the value for initial detection will change the value for Post-Therapy Brady.
- b. All of the AFib Rate Thresholds are linked to the ATR Trigger Rate and Atrial Flutter Response Rate. If any one of these rates is reprogrammed, the others will automatically change to the same value.

Table A-10. Ventricular ATP parameters (specified into a 750 Ω load)

Parameter	VT-1 Zone	VT Zone	VF Zone	Nominal
ATP Type 3 zones	Off; Burst; Ramp; Scan; Ramp/Scan	Off; Burst; Ramp; Scan; Ramp/Scan	--	Off (VT-1); Burst (VT ATP1); Ramp (VT ATP2)
ATP Type 2 zones	--	Off; Burst; Ramp; Scan; Ramp/Scan	--	Burst (VT ATP1); Ramp (VT ATP2)
Number of Bursts (per scheme) 3 zones	Off; 1; 2; ...; 30	Off; 1; 2; ...; 30	--	Off (VT-1); 2 (VT ATP1); 1 (VT ATP2)
Number of Bursts (per scheme) 2 zones	--	Off; 1; 2; ...; 30	--	2 (VT ATP1); 1 (VT ATP2)
Initial Pulse (pulses) 3 zones	1; 2; ...; 30	1; 2; ...; 30	--	4 (VT-1); 10 (VT)
Initial Pulse (pulses) 2 zones	--	1; 2; ...; 30	--	10
Pulse Increment (pulses) 3 zones	0; 1; ...; 5	0; 1; ...; 5	--	0
Pulse Increment (pulses) 2 zones	--	0; 1; ...; 5	--	0
Maximum Number of Pulses 3 zones	1; 2; ...; 30	1; 2; ...; 30	--	4 (VT-1); 10 (VT)
Maximum Number of Pulses 2 zones	--	1; 2; ...; 30	--	10
Coupling Interval (% or ms) 3 zones	50; 53; 56; 59; 63; 66; ...; 84; 88; 91; 94; 97% or 120; 130; ...; 750 ms	50; 53; 56; 59; 63; 66; ...; 84; 88; 91; 94; 97% or 120; 130; ...; 750 ms	--	81% (Tolerance \pm 5 ms)
Coupling Interval (% or ms) 2 zones	--	50; 53; 56; 59; 63; 66; ...; 84; 88; 91; 94; 97% or 120; 130; ...; 750 ms	--	81% (Tolerance \pm 5 ms)
Coupling Interval Decrement (ms) 3 zones	0; 2; ...; 30	0; 2; ...; 30	--	0 (Tolerance \pm 5 ms)
Coupling Interval Decrement (ms) 2 zones	--	0; 2; ...; 30	--	0 (Tolerance \pm 5 ms)
Burst Cycle Length (BCL) (% or ms) 3 zones	50; 53; 56; 59; 63; 66; ...; 84; 88; 91; 94; 97% or 120; 130; ...; 750 ms	50; 53; 56; 59; 63; 66; ...; 84; 88; 91; 94; 97% or 120; 130; ...; 750 ms	--	81% (Tolerance \pm 5 ms)

Table A-10. Ventricular ATP parameters (specified into a 750 Ω load) (continued)

Parameter	VT-1 Zone	VT Zone	VF Zone	Nominal
Burst Cycle Length (BCL) (% or ms) 2 zones	--	50; 53; 56; 59; 63; 66; ...; 84; 88; 91; 94; 97% or 120; 130; ...; 750 ms	--	81% (Tolerance ± 5 ms)
Ramp Decrement (ms) 3 zones ^c	0; 2; ...; 30	0; 2; ...; 30	--	0 (VT-1 ATP1); 10 (VT-1 ATP2); 0 (VT ATP1); 10 (VT ATP2)
Ramp Decrement (ms) 2 zones	--	0; 2; ...; 30	--	0 (VT ATP1); 10 (VT ATP2) (Tolerance ± 5 ms)
Scan Decrement (ms) 3 zones	0; 2; ...; 30	0; 2; ...; 30	--	0 (Tolerance ± 5 ms)
Scan Decrement (ms) 2 zones	--	0; 2; ...; 30	--	0 (Tolerance ± 5 ms)
Minimum Interval (ms) 3 zones	120; 130; ...; 400	120; 130; ...; 400	--	220 (Tolerance ± 5 ms)
Minimum Interval (ms) 2 zones	--	120; 130; ...; 400	--	220 (Tolerance ± 5 ms)
Right Ventricular ATP Pulse Width ^a (ms) 3 zones (one value for all zones)	0.1; 0.2; ...; 2.0	0.1; 0.2; ...; 2.0	--	1.0 (Tolerance ± 0.03 ms at < 1.8 ms; ± 0.08 ms at ≥ 1.8 ms)
Right Ventricular ATP Pulse Width ^a (ms) 2 zones (one value for all zones)	--	0.1; 0.2; ...; 2.0	--	1.0 (Tolerance ± 0.03 ms at < 1.8 ms; ± 0.08 ms at ≥ 1.8 ms)
Left Ventricular ATP Pulse Width ^a (ms) 3 zones (one value for all zones)	0.1; 0.2; ...; 2.0	0.1; 0.2; ...; 2.0	--	1.0 (Tolerance ± 0.03 ms at < 1.8 ms; ± 0.08 ms at ≥ 1.8 ms)
Left Ventricular ATP Pulse Width ^a (ms) 2 zones (one value for all zones)	--	0.1; 0.2; ...; 2.0	--	1.0 (Tolerance ± 0.03 ms at < 1.8 ms; ± 0.08 ms at ≥ 1.8 ms)
Right Ventricular ATP Amplitude ^a (V) 3 zones (one value for all zones)	0.1; 0.2; ...; 3.5; 4.0; ...; 7.5	0.1; 0.2; ...; 3.5; 4.0; ...; 7.5	--	5.0 (Tolerance ± 15% or ± 100 mV, whichever is greater)
Right Ventricular ATP Amplitude ^a (V) 2 zones (one value for all zones)	--	0.1; 0.2; ...; 3.5; 4.0; ...; 7.5	--	5.0 (Tolerance ± 15% or ± 100 mV, whichever is greater)
Left Ventricular ATP Amplitude ^a (V) 3 zones (one value for all zones)	0.1; 0.2; ...; 3.5; 4.0; ...; 7.5	0.1; 0.2; ...; 3.5; 4.0; ...; 7.5	--	5.0 (Tolerance ± 15% or ± 100 mV, whichever is greater)
Left Ventricular ATP Amplitude ^a (V) 2 zones (one value for all zones)	--	0.1; 0.2; ...; 3.5; 4.0; ...; 7.5	--	5.0 (Tolerance ± 15% or ± 100 mV, whichever is greater)
ATP Time-out ^b (min:sec) 3 zones	Off; 00:10; 00:15; ...; 01:00; 01:15; ...; 02:00; 02:30; ...; 10:00; 15:00; ...; 60:00	Off; 00:10; 00:15; ...; 01:00; 01:15; ...; 02:00; 02:30; ...; 10:00; 15:00; ...; 60:00	--	01:00
ATP Time-out (min:sec) 2 zones	--	Off; 00:10; 00:15; ...; 01:00; 01:15; ...; 02:00; 02:30; ...; 10:00; 15:00; ...; 60:00	--	01:00

Table A-10. Ventricular ATP parameters (specified into a 750 Ω load) (continued)

Parameter	VT-1 Zone	VT Zone	VF Zone	Nominal
QUICK CONVERT ATP (VF Only) 1, 2, or 3 zones ^e	--	--	Off; On	On
QUICK CONVERT ATP (VF Only) 1, 2, or 3 zones ^d	--	--	Off; 250; 300	250 (Tolerance ± 5 ms)

- a. The programmed Amplitude and Pulse Width values affect Post Therapy Brady Pacing, but are separately programmable from Normal Brady Pacing, Temporary Brady Pacing, and EP Test.
- b. The VT-1 ATP Time-out must be greater than or equal to the VT ATP Time-out.
- c. Values apply if Burst is selected for the VT-1 ATP parameter.
- d. For models with programmable rate QUICK CONVERT ATP.
- e. For models with non-programmable rate QUICK CONVERT ATP.

Table A-11. Ventricular Shock Parameters

Parameter	Programmable Values	Nominal
Shocks 1 and 2 energy (J) ^{a, b, c} (stored energy)	Off; 0.1; 0.3; 0.6; 0.9; 1.1; 1.7; 2; 3; 5; 6; 7; 9; 11; 14; 17; 21; 23; 26; 29; 31; 36; 41	41 J (Tolerance +150/-60% for 0.1 J; ± 60% for 0.3 J; ± 40% for 0.6–3 J; ± 20% for 5–36 J; ±10% for 41 J) (AUTOGEN, DYNAGEN, INOGEN, and ORIGEN devices) 41 J (Tolerance ± 60% for ≤ 0.3 J; ± 40% for 0.6–3 J; ± 20% for 5–36 J; ± 10% for 41 J) (INCEPTA, ENERGEN, PUNCTUA, and COGNIS devices)
Energy of Remaining Shocks (J) ^{a, c} (stored energy)	Off; 41	41 J (Tolerance ± 10% for 41 J)
Lead Polarity ^d	Initial; Reversed	Initial
Committed Shock	Off; On	Off
Shock Lead Vector	RV Coil to RA Coil and Can; RV Coil to Can; RV Coil to RA Coil	RV Coil to RA Coil and Can

- a. Biphasic energy is specified.
- b. The Shock 2 energy level must be greater than or equal to the Shock 1 energy level.
- c. In a VT-1 zone of a 3-zone configuration or a VT zone of a 2-zone configuration, all or some of the shocks may be programmed to Off while other shocks in that zone are programmed in joules.
- d. A commanded STAT SHOCK is delivered at the programmed Polarity.

Table A-12. Pacing therapy parameters (Normal, Post-Therapy, and Temporary) (specified into a 750 Ω load)

Parameter	Programmable Values	Nominal
Mode ^{a, e}	DDD(R); DDI(R); VDD(R); VVI(R); AAI(R); Off; Temporary: DDD; DDI; DOO; VDD; VVI; VOO; AAI; AOO; Off	DDD
Lower Rate Limit (LRL) ^{a, b, c} (min ⁻¹)	30; 35; ...; 185	45 (Tolerance ± 5 ms)
Maximum Tracking Rate (MTR) ^e (min ⁻¹)	50; 55; ...; 185	130 (Tolerance ± 5 ms)
Maximum Sensor Rate (MSR) ^{e, h} (min ⁻¹)	50; 55; ...; 185	130 (Tolerance ± 5 ms)
Pulse Amplitude ^{a, c, d, m} (atrium) (V)	Auto: 0.1; 0.2; ...; 3.5; 4.0; ...; 5.0; Temporary: 0.1; 0.2; ...; 3.5; 4.0; ...; 5.0	3.5 (5.0 post-therapy) (Tolerance ± 15% or ± 100mV, whichever is greater)
Pulse Amplitude ^{a, c, d, m} (right ventricle) (V)	Auto: 0.1; 0.2; ...; 3.5; 4.0; ...; 7.5; Temporary: 0.1; 0.2; ...; 3.5; 4.0; ...; 7.5	3.5 (5.0 post-therapy) (Tolerance ± 15% or ± 100mV, whichever is greater)
Pulse Amplitude Daily Trend ^k (independently programmable in each chamber)	Disabled; Enabled	Disabled
Pulse Width ^{a, c, d, i} (atrium, right ventricle) (ms)	0.1; 0.2; ...; 2.0	0.4 (1.0 post-therapy) (Tolerance ± 0.03 ms at < 1.8 ms; ± 0.08 ms at ≥ 1.8 ms)
Atrial Pace/Sense Configuration ^{a, e}	Bipolar; Off	Bipolar

Table A–12. Pacing therapy parameters (Normal, Post-Therapy, and Temporary) (specified into a 750 Ω load) (continued)

Parameter	Programmable Values	Nominal
Accelerometer ^{e h n}	On; Passive	Passive
Accelerometer Activity Threshold ^{e h}	Very High; High; Medium High; Medium; Medium Low; Low; Very Low	Medium
Accelerometer Reaction Time ^{e h} (sec)	10; 20; ...; 50	30
Accelerometer Response Factor ^{e h}	1; 2; ...; 16	8
Accelerometer Recovery Time ^{e h} (min)	2; 3; ...; 16	2
Minute Ventilation ^{e h}	On; Passive; Off	Passive
Minute Ventilation Response Factor ^{e h}	1; 2; ...; 16	8
Minute Ventilation Fitness Level	Sedentary; Active; Athletic; Endurance Sports	Active
Patient's Age ⁱ	≤5; 6–10; 11–15; ...; 91–95; ≥96	56–60
Patient's Gender ⁱ	Male; Female	Male
Ventilatory Threshold (min ⁻¹)	30; 35; ...; 185	115 (Tolerance ± 5 ms)
Ventilatory Threshold Response (%)	Off; 85; 70; 55	70
Maximum PVARP ^{a e} (ms)	150; 160; ...; 500	280 (Tolerance ± 5 ms)
Minimum PVARP ^{a e} (ms)	150; 160; ...; 500	240 (Tolerance ± 5 ms)
PVARP After PVC ^{a e} (ms)	Off; 150; 200; ...; 500	400 (Tolerance ± 5 ms)
RV-Blank After A-Pace ^{a f} (ms)	45; 65; 85; Smart	65 (Tolerance ± 5 ms)
A-Blank After V-Pace ^{a f} (ms)	85; 105; 125; Smart	Smart (Tolerance ± 5 ms)
A-Blank After RV-Sense ^{a f} (ms)	45; 65; 85; Smart	Smart (Tolerance ± 5 ms)
Maximum VRP (right ventricle) ^{a e} (ms)	150; 160; ...; 500	250 (Tolerance ± 5 ms)
Minimum VRP (right ventricle) ^{a g} (ms)	150; 160; ...; 500	230 (Tolerance ± 5 ms)
Maximum Paced AV Delay ^{a e} (ms)	30; 40; ...; 300	180 (Tolerance ± 5 ms)
Minimum Paced AV Delay ^{a e} (ms)	30; 40; ...; 300	180 (Tolerance ± 5 ms)
Maximum Sensed AV Delay ^{a e} (ms)	30; 40; ...; 300	120 (Tolerance ± 5 ms)
Minimum Sensed AV Delay ^{a e} (ms)	30; 40; ...; 300	120 (Tolerance ± 5 ms)
Respiratory Sensor ^{a e}	Off; On	Off
Respiration-related Trends ^{l o}	Off; On	On
Tracking Preference ^{e h}	Off; On	On
Rate Hysteresis Hysteresis Offset ^{e h} (min ⁻¹)	-80; -75; ...; -5; Off	Off (Tolerance ± 5 ms)
Rate Hysteresis Search Hysteresis ^{e h} (cycles)	Off; 256; 512; 1024; 2048; 4096	Off (Tolerance ± 1 cycle)
Rate Smoothing (up, down) ^{e h} (%)	Off; 3; 6; 9; 12; 15; 18; 21; 25	Off (Tolerance ± 1%)
Rate Smoothing Maximum Pacing Rate (MPR) ^e (min ⁻¹)	50; 55; ...; 185	130 (Tolerance ± 5 ms)

Table A–12. Pacing therapy parameters (Normal, Post-Therapy, and Temporary) (specified into a 750 Ω load) (continued)

Parameter	Programmable Values	Nominal
Noise Response ^{a e}	AOO; VOO; DOO; Inhibit Pacing	DOO for DDD(R) and DDI(R) modes; VOO for VDD(R) and VVI(R) modes; AOO for AAI(R) mode
Post Therapy Pacing Period (min:sec) (available post-shock only)	00:15; 00:30; 00:45; 01:00; 01:30; 02:00; 03:00; 04:00; 05:00; 10:00; 15:00; 30:00; 45:00; and 60:00	00:30 (Tolerance ± 1 cardiac cycle)

- a. The programmed Normal Brady values will be used as the nominal values for Temporary Brady pacing.
- b. The basic pulse period is equal to the pacing rate and the pulse interval (no hysteresis). Runaway protection circuitry inhibits bradycardia pacing above 205 min⁻¹. Magnet application does not affect pacing rate (test pulse interval).
- c. Separately programmable for ATP/Post-shock, Temporary Brady, and EP Test.
- d. Values are not affected by temperature variation within the range 20°–43°C.
- e. This parameter is used globally in Normal Brady pacing and Post-Therapy Brady pacing. Changing the value for Normal Brady will change the value for Post-Therapy Brady.
- f. This parameter is automatically set to at least 85 ms for Post-Therapy Brady.
- g. This parameter is automatically adjusted in Post-Therapy Brady to allow appropriate sensing.
- h. This parameter is disabled during Temporary Brady.
- i. When the Pulse Amplitude is set to Auto or Pulse Amplitude Daily Trend is enabled the Pulse Width is fixed at 0.4 ms.
- j. This parameter is used for calculating Ventilatory Threshold Response.
- k. This parameter is automatically enabled if Auto is selected for the Pulse Amplitude.
- l. This value is located on the Lead Setup screen.
- m. Auto is available in models which contain the PaceSafe feature.
- n. For INCEPTA, ENERGEN, PUNCTUA and COGNIS devices, the Accelerometer parameter is controlled by the Brady Mode (rate adaptive versus non-rate adaptive).
- o. This parameter is used to control the Respiratory Sensor.

Table A–13. Brady/CRT left ventricular pacing parameters (specified into a 750 Ω load)

Parameter	Programmable Values	Nominal
Ventricular Pacing Chamber ^{a b}	RV Only; BiV; LV Only	BiV
LV Offset ^{a b} (ms)	-100; -90; ...; 0; +10; ...; +100	0 (Tolerance ± 5 ms)
Pulse Amplitude ^{a c d i} (left ventricle) (V)	Auto; 0.1; 0.2; ...; 3.5; 4.0; ...; 7.5; Temporary: 0.1; 0.2; ...; 3.5; 4.0; ...; 7.5	3.5 (5.0 post therapy) (Tolerance ± 15% or ± 100mV) (whichever is greater)
Pulse Amplitude Daily Trend ^g (left ventricle)	Disabled; Enabled	Disabled
Pulse Width ^{a c d} (left ventricle) (ms)	0.1; 0.2; ...; 2.0	0.4 (1.0 post therapy) (Tolerance ± 0.03 ms at < 1.8 ms; ± 0.08 ms at ≥ 1.8 ms)
LV-Blank After A-Pace ^{a e} (ms)	45; 65; 85; Smart	Smart (Tolerance ± 5 ms)
LVRP ^{a b} (ms)	250; 260; ...; 500	250 (Tolerance ± 7.5 ms)
LVPP ^{a b} (ms)	300; 350; ...; 500	400 (Tolerance ± 5 ms)
BiV Trigger ^{b h}	Off; On	Off
BiV/VRR Maximum Pacing Rate ^{b f} (min ⁻¹)	50; 55; ...; 185	130 (Tolerance ± 5 ms)
Left Ventricular Electrode Configuration ^{a b}	Dual; Single; None	None
Left Ventricular Electrode Configuration ^{a b}	Quadripolar (Non-programmable)	Quadripolar
Left Ventricular Pace Configuration ^{a b}	Single or Dual: LVtip>>Can LVtip>>RV Dual Only: LVring>>Can LVring>>RV LVtip>>LVring LVring>>LVtip	Single: LVtip>>RV Dual: LVtip>>RV (AUTOGEN, DYNAGEN, INOGEN, and ORIGEN devices) Dual: LVtip>>LVring (INCEPTA, ENERGEN, PUNCTUA, and COGNIS devices)
Left Ventricular Pace Configuration ^{a b}	Quadripolar: LVTip1>>LVRing2 LVTip1>>LVRing3 LVTip1>>LVRing4 LVTip1>>RV	LVTip1>>RV

Table A-13. Brady/CRT left ventricular pacing parameters (specified into a 750 Ω load) (continued)

Parameter	Programmable Values	Nominal
	LVTip1>>Can LVRing2>>LVRing3 LVRing2>>LVRing4 LVRing2>>RV LVRing2>>Can LVRing3>>LVRing2 LVRing3>>LVRing4 LVRing3>>RV LVRing3>>Can LVRing4>>LVRing2 LVRing4>>LVRing3 LVRing4>>RV LVRing4>>Can	
Left Ventricular Sense Configuration ^{a b}	Single or Dual: LVtip>>Can LVtip>>RV Off Dual Only: LVring>>Can LVring>>RV LVtip>>LVring	Single: LVtip>>RV Dual: LVtip>>LVring
Left Ventricular Sense Configuration ^{a b}	Quadripolar: LVTip1>>LVRing2 LVTip1>>LVRing3 LVTip1>>LVRing4 LVTip1>>RV LVTip1>>Can LVRing2>>LVRing3 LVRing2>>RV LVRing2>>Can Off (Disable Sensing)	LVTip1>>LVRing2
PaceSafe LV Automatic Threshold Maximum Amplitude (V)	2.5; 3.0; ...; 7.5	5.0
PaceSafe LV Automatic Threshold Safety Margin (V)	0.5; 1.0; ...; 2.5	1.0

- a. The programmed Normal Brady values will be used as the nominal values for Temporary Brady pacing.
- b. This parameter is used globally in Normal Brady pacing and Post-Therapy Brady pacing. Changing the value for Normal Brady will change the value for Post-Therapy Brady.
- c. Separately programmable for ATP/Post-shock, Temporary Brady, and EP Test.
- d. Values are not affected by temperature variation within the range 20°–43°C.
- e. This parameter is automatically set to at least 85 ms for Post-Therapy Brady.
- f. The BiV/VRR Maximum Pacing Rate is shared by BiV Trigger and VRR, changing the value for BiV MPR will also change the value for VRR MPR.
- g. This parameter is automatically enabled if Auto is selected for Pulse Amplitude.
- h. This parameter is disabled during Temporary Brady.
- i. Auto is available in models which contain the PaceSafe feature.

Table A-14. Atrial Tachy Parameters

Parameter	Programmable Values	Nominal
ATR Mode Switch ^{a b}	Off; On	On
ATR Trigger Rate ^{a b f} (min ⁻¹)	100; 110; ...; 300	170 (Tolerance ± 5 ms)
ATR Duration ^{a b} (cycles)	0; 8; 16; 32; 64; 128; 256; 512; 1024; 2048	8 (Tolerance ± 1 cardiac cycle)
ATR Entry Count ^{a b} (cycles)	1; 2; ...; 8	8
ATR Exit Count ^{a b} (cycles)	1; 2; ...; 8	8
ATR Fallback Mode ^{b g}	VDI; DDI; VDIR; DDIR	DDI
ATR Fallback Time ^{a b} (min:sec)	00:00; 00:15; 00:30; 00:45; 01:00; 01:15; 01:30; 01:45; 02:00	00:30
ATR/VTR Fallback LRL ^{a b} (min ⁻¹)	30; 35; ...; 185	70 (Tolerance ± 5 ms)
ATR Ventricular Rate Regulation (VRR) ^{a b}	Off; Min; Med; Max	Min

Table A-14. Atrial Tachy Parameters (continued)

Parameter	Programmable Values	Nominal
ATR BiV Trigger ^{a b}	Off; On	On
ATR Maximum Pacing Rate (MPR) ^{a b e} (min ⁻¹)	50; 55; ...; 185	130 (Tolerance ± 5 ms)
Atrial Flutter Response ^{b c}	Off; On	Off
Atrial Flutter Response Trigger Rate ^{b c f} (min ⁻¹)	100; 110; ...; 300	170 (Tolerance ± 5 ms)
PMT Termination ^{b c}	Off; On	On
Ventricular Rate Regulation (VRR) ^{b c}	Off; Min; Med; Max	Off
BiV/VRR Maximum Pacing Rate (MPR) ^{b c d} (min ⁻¹)	50; 55; ...; 185	130 (Tolerance ± 5 ms)

- a. The programmed Normal Brady values will be used as the nominal values for Temporary Brady pacing.
- b. This parameter is used globally in Normal Brady pacing and Post-Therapy Brady pacing. Changing the value for Normal Brady will change the value for Post-Therapy Brady.
- c. This parameter gets disabled during Temporary Brady.
- d. The BiV/VRR MPR is shared by VRR and BiV Trigger. Changing this parameter for VRR will also change the MPR value for BiV Trigger.
- e. The ATR MPR is shared by ATR VRR and ATR BiV Trigger. Changing this parameter for ATR VRR will also change the MPR value for ATR BiV Trigger.
- f. ATR Trigger Rate and Atrial Flutter Response Rate are linked to all the AFib Rate Thresholds. If any one of these rates is reprogrammed, the others will automatically change to the same value.
- g. If Normal Brady ATR Fallback Mode is DDIR or DDI, then Temporary Brady ATR Fallback Mode is DDI. If Normal Brady ATR Fallback Mode is VDIR or VDI, then Temporary Brady ATR Fallback Mode is VDI.

Table A-15. MRI Protection parameters

Parameter	Programmable Values	Nominal
MRI Brady Mode	Off; VOO; AOO; DOO	--
MRI Lower Rate Limit (LRL) (min ⁻¹)	30; 35; ...; 100	20 min ⁻¹ above the normal mode LRL
MRI Ventricular Pacing Chamber	RV Only; BiV	If normal mode Pacing Chamber is RV Only or BiV, same as normal mode Pacing Chamber; If normal mode Pacing Chamber is LV Only, BiV
MRI Atrial Amplitude (V)	2.0; 2.1; ...; 3.5; 4.0; ...; 5.0	5.0 (Tolerance ± 15% or ± 100 mV, whichever is greater) ^a
MRI Right Ventricular Amplitude (V)	2.0; 2.1; ...; 3.5; 4.0; ...; 5.0	5.0 (Tolerance ± 15% or ± 100 mV, whichever is greater) ^a
MRI Left Ventricular Amplitude (V)	2.0; 2.1; ...; 3.5; 4.0; ...; 5.0	Same as the normal mode LV Amplitude, capped between 2.0 and 5.0 (Tolerance ± 15% or ± 100 mV, whichever is greater) ^a
MRI Left Ventricular Pulse Width (ms)	0.1; 0.2; ...; 2.0	Same as the normal mode LV Pulse Width (Tolerance ± 0.03 ms at < 1.8 ms; ± 0.08 ms at ≥ 1.8 ms)
MRI Protection Time-out (hours)	Off; 3; 6; 9; 12	6

- a. During the transition into the MRI Protection Mode, it may take up to 6 cardiac pacing cycles for the pace amplitude to meet the specified tolerance range.

Table A-16. Magnet and Beep functions

Parameter	Programmable Values	Nominal
Magnet Response	Off; Store EGM; Inhibit Therapy	Inhibit Therapy
Beep During Capacitor Charge	Off; On	Off
Beep When Explant is Indicated	Off; On	On
Atrial Beep When Out-of-Range	Off; On	Off
Right Ventricular Beep When Out-of-Range	Off; On	Off

Table A-16. Magnet and Beeper functions (continued)

Parameter	Programmable Values	Nominal
Left Ventricular Beep When Out-of-Range	Off; On	Off
Shock Beep When Out-of-Range	Off; On	Off
Beeper (post-MRI)	Off; On	Off

Table A-17. Sensitivity Adjustment

Parameter	Programmable Values	Nominal
Atrial Sensitivity ^a (mV)	AGC 0.15; AGC 0.2; AGC 0.25; AGC 0.3; AGC 0.4; ...; AGC 1.0; AGC 1.5	AGC 0.25
Right Ventricular Sensitivity ^a (mV)	AGC 0.15; AGC 0.2; AGC 0.25; AGC 0.3; AGC 0.4; ...; AGC 1.0; AGC 1.5	AGC 0.6
Left Ventricular Sensitivity ^a (mV)	AGC 0.15; AGC 0.2; AGC 0.25; AGC 0.3; AGC 0.4; ...; AGC 1.0; AGC 1.5	AGC 1.0

a. With CENELEC waveform, per EN 45502-2-2:2008.

Table A-18. Daily Lead Measurements

Parameter	Programmable Values	Nominal
Atrial Daily Intrinsic Amplitude	On; Off	On
Right Ventricular Daily Intrinsic Amplitude	On; Off	On
Left Ventricular Daily Intrinsic Amplitude	On; Off	On
Atrial Daily Impedance	On; Off	On
Right Ventricular Daily Impedance	On; Off	On
Left Ventricular Daily Impedance	On; Off	On
Shock Daily Impedance	On; Off	On
Atrial Low Impedance Limit (Ω)	200; 250; ...; 500	200
Atrial High Impedance Limit (Ω)	2000; 2250; ...; 3000 (AUTOGEN, DYNAGEN, INOGEN, and ORIGEN devices) 2000; 2250; 2500 (INCEPTA, ENERGEN, PUNCTUA, and COGNIS devices)	2000
Right Ventricular Low Impedance Limit (Ω)	200; 250; ...; 500	200
Right Ventricular High Impedance Limit (Ω)	2000; 2250; ...; 3000 (AUTOGEN, DYNAGEN, INOGEN, and ORIGEN devices) 2000; 2250; 2500 (INCEPTA, ENERGEN, PUNCTUA, and COGNIS devices)	2000
Left Ventricular Low Impedance Limit (Ω)	200; 250; ...; 500	200
Left Ventricular High Impedance Limit (Ω)	2000; 2250; ...; 3000 (AUTOGEN, DYNAGEN, INOGEN, and ORIGEN devices) 2000; 2250; 2500 (INCEPTA, ENERGEN, PUNCTUA, and COGNIS devices)	2000
Shock High Impedance Limit (Ω)	125; 150; 175; 200	125

Table A–19. Ventricular Commanded ATP

Parameter ^a	Programmable Values	Nominal
Commanded Ventricular ATP (Type)	Burst; Ramp; Scan; Ramp/Scan	Burst
Number Of Bursts	1; 2; ...; 30	30
Initial Pulses per Burst (pulses)	1; 2; ...; 30	4
Pulse Increment (pulses)	0; 1; ...; 5	0
Maximum Number of Pulses	1; 2; ...; 30	4
Coupling Interval (% or ms)	50; 53; 56; 59; 63; 66; ...; 84; 88; 91; 94; 97% or 120; 130; ...; 750 ms	81% (Tolerance \pm 5 ms)
Coupling Interval Decrement (ms)	0; 2; ...; 30	0 (Tolerance \pm 5 ms)
Burst Cycle Length (BCL) (% or ms)	50; 53; 56; 59; 63; 66; ...; 84; 88; 91; 94; 97% or 120; 130; ...; 750 ms	81% (Tolerance \pm 5 ms)
Ramp Decrement (ms)	0; 2; ...; 30	0 (Tolerance \pm 5 ms)
Scan Decrement (ms)	0; 2; ...; 30	0 (Tolerance \pm 5 ms)
Minimum Interval (ms)	120; 130; ...; 400	200 (Tolerance \pm 5 ms)

a. The ventricular Commanded ATP Pulse Width and Amplitude values are the same as programmed for ventricular ATP therapy.

Table A–20. 50 Hz/Manual Burst Pacing

Parameter ^a	Programmable Values	Nominal
Burst Interval (ms)	20; 30; ...; 750	600 (Tolerance \pm 5 ms)
Minimum Interval (ms)	20; 30; ...; 750	200 (Tolerance \pm 5 ms)
Decrement (ms)	0; 10; ...; 50	50 (Tolerance \pm 5 ms)

a. Applied to the atrium or ventricle depending on the chamber selected.

Table A–21. Ventricular Commanded Shock

Parameter	Programmable Values	Nominal
Shock (J) (stored energy)	0.1; 0.3; 0.6; 0.9; 1.1; 1.7; 2; 3; 5; 6; 7; 9; 11; 14; 17; 21; 23; 26; 29; 31; 36; 41	41 J (Tolerance +150/-60% for 0.1 J; \pm 60% for 0.3 J; \pm 40% for 0.6–3 J; \pm 20% for 5–36 J; \pm 10% for 41 J) (AUTOGEN, DYNAGEN, INOGEN, and ORIGEN devices) 41 J (Tolerance \pm 60% for \leq 0.3 J; \pm 40% for 0.6–3J; \pm 20% for 5–36 J; \pm 10% for 41 J) (INCEPTA, ENERGEN, PUNCTUA, and COGNIS devices)
Coupling Interval (ms)	SYNC; 50; 60; ...; 500	SYNC

Table A–22. VFib (Ventricular Fibrillation) Induction

Parameter	Values
V Fib High	15V (nonprogrammable) (Tolerance \pm 10V)
V Fib Low	9V (nonprogrammable) (Tolerance \pm 7V)

Table A-23. Shock on T Induction

Parameter	Programmable Values	Nominal
Shock (J) (stored energy)	0.1; 0.3; 0.6; 0.9; 1.1; 1.7; 2; 3; 5; 6; 7; 9; 11; 14; 17; 21; 23; 26; 29; 31; 36; 41	1.1 J (Tolerance +150/-60% for 0.1 J; ± 60% for 0.3 J; ± 40% for 0.6–3 J; ± 20% for 5–36 J; ±10% for 41 J) (AUTOGEN, DYNAGEN, INOGEN, and ORIGEN devices) 1.1 J (Tolerance ± 60% for ≤ 0.3 J; ± 40% for 0.6–3J; ± 20% for 5–36 J; ± 10% for 41 J) (INCEPTA, ENERGEN, PUNCTUA, and COGNIS devices)
Number of S1 Pulses	1; 2; ...; 30	8
S1 Interval (ms)	120; 130; ...; 750	400
Coupling Interval (ms)	SYNC; 10; 20; ...; 500	310

Table A-24. Sensor Trending

Parameter	Programmable Values	Nominal
Recording Method	Beat To Beat; Off; 30 Second Average	30 Second Average
Data Storage	Continuous; Fixed	Continuous

Table A-25. Backup EP Test

Parameter	Programmable Values	Nominal
Backup Pacing Mode ^a	Off; On	On
Backup Pacing Lower Rate Limit ^{a b} (min ⁻¹)	30; 35; ...; 185	45 (Tolerance ± 5 ms)
Backup Pacing RV Refractory ^{a b} (ms)	150; 160; ...; 500	250 (Tolerance ± 5 ms)
Backup Pacing Ventricular Pacing Chamber ^a	BiV (nonprogrammable)	BiV
EP Test Pacing Outputs Atrial Amplitude (when test is in the atrium) (V)	Off; 0.1; 0.2; ...; 3.5; 4.0; ...; 5.0	5.0 (Tolerance ± 15% or 100 mV, whichever is greater)
EP Test Pacing Outputs RV Amplitude (V)	Off; 0.1; 0.2; ...; 3.5; 4.0; ...; 7.5	7.5 (Tolerance ± 15% or 100 mV, whichever is greater)
EP Test Pacing Outputs LV Amplitude (V)	Off; 0.1; 0.2; ...; 3.5; 4.0; ...; 7.5	7.5 (Tolerance ± 15% or 100 mV, whichever is greater)
EP Test Pacing Outputs Atrial Pulse Width (when test is in the atrium) (ms)	0.1; 0.2; ...; 2.0	1.0 (Tolerance ± 0.03 ms at < 1.8 ms; ± 0.08 ms at ≥ 1.8 ms)
EP Test Pacing Outputs RV Pulse Width (ms)	0.1; 0.2; ...; 2.0	1.0 (Tolerance ± 0.03 ms at < 1.8 ms; ± 0.08 ms at ≥ 1.8 ms)
EP Test Pacing Outputs LV Pulse Width (ms)	0.1; 0.2; ...; 2.0	1.0 (Tolerance ± 0.03 ms at < 1.8 ms; ± 0.08 ms at ≥ 1.8 ms)

a. This parameter only applies when the test is in the atrium.

b. The programmed Normal Brady value will be used as the nominal value.

Table A-26. PES (Programmed Electrical Stimulation)

Parameter ^a	Programmable Values	Nominal
Number of S1 Intervals (pulses)	1; 2; ...; 30	8
S2 Decrement (ms)	0; 10; ...; 50	0
S1 Interval (ms)	120; 130; ...; 750	600 (Tolerance ± 5 ms)
S2 Interval (ms)	Off; 120; 130; ...; 750	600 (Tolerance ± 5 ms)

Table A–26. PES (Programmed Electrical Stimulation) (continued)

Parameter ^a	Programmable Values	Nominal
S3 Interval (ms)	Off; 120; 130; ...; 750	Off (Tolerance \pm 5 ms)
S4 Interval (ms)	Off; 120; 130; ...; 750	Off (Tolerance \pm 5 ms)
S5 Interval (ms)	Off; 120; 130; ...; 750	Off (Tolerance \pm 5 ms)

a. Applied to the atrium or ventricle as commanded by the programmer.

Остаряла версия. Да не се използва.
 Zastaralá verze. Nepoužívat.
 Forældet version. Må ikke anvendes.
 Version überholt. Nicht verwenden.
 Aegunud versioon. Ärge kasutage.
 Παλιά έκδοση. Μην την χρησιμοποιείτε.
 Outdated version. Do not use.
 Versión obsoleta. No utilizar.
 Zastarjela verzija. Nemojte upotrebljavati.
 Úreлт útgáfa. Notið ekki.
 Versione obsoleta. Ne pas utiliser.
 Pasenusi versija. Neizmantot.
 Elavult verzió. Ne használja!
 Dit is een verouderde versie. Niet gebruiken.
 Utdatert versjon. Skal ikke brukes.
 Wersja przeterminowana. Nie używać.
 Versão obsoleta. Não utilize.
 Versiune expirată. A nu se utiliza.
 Zastaraná verzia. Nepoužívať.
 Vanhentunut versio. Älä käytä.
 Föråldrad version. Använd ej.
 Güncel olmayan sürüm. Kullanmayın.

Остаряла версия. Да не се използва.
Zastaralá verze. Nepoužívat.
Forældet version. Må ikke anvendes.
Version überholt. Nicht verwenden.
Aegunud versioón. Äрге kasutage.
Παλιά έκδοση. Μην την χρησιμοποιείτε.
Outdated version. Do not use.
Versión obsoleta. No utilizar.
Zastarjela verzija. Nemojte upotrebljavati.
Úreilt útgáfa. Notið ekki.
Versione obsoleta. Ne pas utiliser.
Zastarjela verzija. Nemojte upotrebljavati.
Novecojsi versija. Non utilizzare.
Elavult verzió. Ne használja!
Dit is een verouderde versie. Niet gebruiken.
Wersja przeterminowana. Nie używać.
Utdatert versjon. Skal ikke brukes.
Versão obsoleta. Não utilize.
Versiune expirată. A nu se utiliza.
Zastaraná verzia. Nepoužívať.
Zastarela različica. Ne uporabite.
Vanhentunut versio. Älä käytä.
Föråldrad version. Använd ej.
Güncel olmayan sürüm. Kullanmayın.

SYMBOLS ON PACKAGING

APPENDIX B















SYMBOLS ON PACKAGING

The following symbols may be used on packaging and labeling (Table B–1 Symbols on packaging on page B-1):

Table B–1. Symbols on packaging

Symbol	Description
	Reference number
	Package contents
	Pulse generator
	Torque wrench
	Literature enclosed
	Serial number
	Use by
	Lot number
	Date of manufacture
	Non-ionizing electromagnetic radiation
	Sterilized using ethylene oxide
	Do not resterilize
	Do not reuse
	Do not use if package is damaged
	Dangerous voltage
	Consult instructions for use on this website: www.bostonscientific-elabeling.com
	Temperature limitation
	CE mark of conformity with the identification of the notified body authorizing use of the mark

Table B-1. Symbols on packaging (continued)

Symbol	Description
	RTTE designation for radio equipment with a use restriction
	Place telemetry wand here
	Open here
	Authorized Representative in the European Community
	Manufacturer
	C-Tick with supplier codes
	Australian Communications and Media Authority (ACMA) radio compliance mark
	New Zealand Radio Spectrum Management (RSM) radio compliance mark
	Australian Sponsor Address
	MR Conditional
	CRT-D RA, RV, LV
	ICD RA, RV
	ICD RV
	Uncoated device
	RF Telemetry

Остаряла версия. Да не се използва.
Zastaralá verze. Nepoužívat.
Forældet version. Må ikke anvendes.
Version überholt. Nicht verwenden.
Aegunud versioón. Myn þyn χρησιμοποιεíte.
Παλιά έκδοση. Μην την χρησιμοποιείτε.
Outdated version. Do not use.
Versión obsoleta. No utilizar.
Zastarjela verzija. Nemojte upotrebljavati.
Úreilt útgáfa. Notið ekki.
Versione obsoleta. Ne pas utiliser.
Zastarjela verzija. Nenaudokite.
Novecojsi versija. Non utilizzare.
Elavult verzió. Ne használja!
Dit is een verouderde versie. Niet gebruiken.
Wersja przeterminowana. Nie używać.
Versão obsoleta. Não utilize.
Versione expiratá. A nu se utiliza.
Zastaraná verzia. Nepoužívať.
Vanhentunut versio. Älä käytä.
Föråldrad version. Använd ej.
Güncel olmayan sürüm. Kullanmayın.

INDEX

Symbols

50 Hz/manual burst pacing 7-7

A

A-blank

after RV-sense 4-72

after V-pace 4-72

A-tachy response (ATR)

mode switch 4-46

ABM (Autonomic Balance Monitor) 6-15

Accelerate, in zone 3-3

Accelerometer 4-31

activity threshold 4-32

reaction time 4-33

recovery time 4-34

response factor 4-31

Activity threshold 4-32

Adaptive-rate pacing 4-30

AFib rate threshold 2-25, 2-30–2-31

AGC (automatic gain control) 4-26

Amplitude 4-14

ATP (antitachycardia pacing) 3-13

intrinsic test 5-12

AP Scan 6-16

ApneaScan 6-16

Application screen 1-2

Arrhythmia logbook 6-2

episode detail 6-5

events summary 6-5

interval 6-8

stored EGM 6-5

ATP (antitachycardia pacing) 3-7

amplitude 3-13

burst cycle length (BCL) 3-10

burst scheme 3-11

commanded, EP test 7-9

coupling interval 3-9

minimum interval 3-11

number of bursts 3-8

pulse count 3-8

pulse width 3-13

ramp scheme 3-11

ramp/scan scheme 3-12

redetection after ATP 2-16

scan scheme 3-12

time-out 3-13

ATR (atrial tachy response)

atrial flutter response 4-50

biventricular trigger 4-50

duration 4-47

end of ATR episode 4-49

entry count 4-47

exit count 4-48

LRL, fallback 4-48

maximum pacing rate 4-50

mode switch 4-46

mode, fallback 4-48

PMT termination 4-51

rate threshold 4-47

time, fallback 4-48

ventricular rate regulation 4-49

VTR (ventricular tachy response) 4-49

ATR Trigger Rate 4-47

Atrial

refractory period, post ventricular atrial (PVARP) 4-66

refractory period, same chamber 4-69

use of atrial information 2-6

Atrial flutter response 4-50

Atrial tachy

ATR mode switch 4-46

atrial flutter response 4-50

PMT termination 4-51

ventricular rate regulation 4-49

Attention conditions, yellow 1-7

Automatic Intrinsic Rhythm ID 2-8

Automatic threshold

LVAT 4-22

RAAT 4-14

RVAT 4-18

AV delay 4-61

paced 4-61

sensed 4-62

B

Backup ventricular pacing during atrial stimulation,

EP test 7-5

Battery

Explant status 5-3

icon 1-5

indicator 5-3

status 5-2

Beep

during capacitor charge 5-6

feature setup 6-22

Biventricular trigger 4-50

maximum pacing rate 4-50

Blanking 4-70

A-blank after RV-sense 4-72

A-blank after V-pace 4-72

LV-blank after A-pace 4-72

RV-blank after A-pace 4-71

Blended Sensors 4-42

Brady Tachy Response (BTR) 4-80

Burst

ATP (antitachycardia pacing) 3-8

cycle length (BCL) 3-10

minimum interval 3-11

number of bursts 3-8

pacing, 50 Hz/manual burst 7-7

parameter 3-8

pulse count 3-8

scheme 3-11

Buttons, software 1-5

C

- Capacitor
 - deformation 3-16, 5-6
 - re-formation 5-6
- Charge time 3-16
 - measurement 5-6
- Check
 - icon 1-6
- Commanded
 - ATP, EP test 7-9
 - shock, EP test 7-8
 - therapy, EP test 7-8
- Committed shock 2-11, 3-18
- Communication, telemetry
 - Radio frequency (RF) 1-8
- Continue
 - icon 1-6
- Counter
 - brady/CRT 6-11
 - therapy history 6-10
 - ventricular 6-10
- Coupling interval 3-9
 - decrement 3-9
- CRT (cardiac resynchronization therapy) delivery zone 2-6

D

- Daily measurements 5-7
- Data
 - disk 1-18
 - patient 1-18
 - storage 1-18
 - USB 1-18
- Decelerate, in zone 3-3
- Decrement
 - coupling interval 3-9
 - ramp scheme 3-11
 - scan scheme 3-12
- Defibrillation
 - backup defibrillator, safety mode 1-21
- Demonstration
 - Programmer/recorder/monitor (PRM) mode 1-3, 1-8
- Detail icon 1-5
- Detection
 - AFib rate threshold 2-25
 - duration 2-14
 - enhancement 2-7, 2-19
 - episode 2-17
 - onset 2-29
 - rate sensing 2-4
 - rate threshold 2-5
 - reconfirmation/committed shock 3-18
 - redetection 2-11
 - RhythmMatch Threshold 2-22
 - stability 2-27
 - sustained rate duration (SRD) 2-30
 - tachyarrhythmia 2-2
 - tachyarrhythmia, safety mode 1-21
 - V rate > A rate 2-24

- vector timing and correlation 2-22
- ventricular, initial 2-7
- window 2-12
- Device
 - memory 1-19
 - mode 2-2
 - programming recommendation 4-3
- Diagnostic
 - battery status 5-2
 - heart rate variability (HRV) 6-11
 - histogram 6-9
 - lead test 5-11
 - patient triggered monitor 6-21
- Disk
 - data 1-18
 - read 1-18
 - save 1-18
- DIVERT THERAPY 1-16
- Dual-Sensor Blending 4-42
- Duration 2-14
 - ATR (atrial tachy response) 4-47
 - post-shock 2-16
 - redetection 2-16
- Dynamic Noise Algorithm 4-28, 4-76

E

- ECG (electrocardiogram)
 - display 1-3
 - surface 1-3
 - wireless 1-4
- EGM (electrogram)
 - display 1-3
 - left ventricular (LV) 4-57
 - real-time 1-3
- Electrocautery
 - mode 2-2
- Electrode, lead configuration 4-57
- End of ATR episode 4-49
- Energy
 - shock 3-15
- Enhancement
 - detection 2-7, 2-19
- Entry count 4-47
- EP test (electrophysiologic test) 7-2
 - ATP, commanded 7-9
 - backup ventricular pacing during atrial stimulation 7-5
 - burst pacing, 50 Hz/manual 7-7
 - commanded therapy 7-8
 - fibrillation 7-4
 - induction 7-4
 - mode, temporary 7-2
 - programmed electrical stimulation (PES) 7-6
 - shock on T 7-5
 - shock, commanded 7-8
 - VFib 7-4
- Episode 2-17
 - end of ATR 4-49
 - Non-Treated 2-18
 - nontreated 6-10
 - treated 6-10

Treated 2-18
ventricular 2-17
Event
counter 6-10
icon 1-6
summary 6-5
therapy history 6-2
Exit count 4-48

F

Fallback, atrial mode switch
LRL 4-48
mode 4-48
time 4-48
Fibrillation
VFib induction 7-4
Fitness Level 4-41
Follow-up
Lead status 5-7

H

Heart failure 4-3
Heart rate variability (HRV) 6-11
Histogram 6-9
Hold
icon 1-6
Horizontal slider
icon 1-6
Hysteresis, rate 4-53

I

Icon
battery 1-5
check 1-6
continue 1-6
details 1-5
event 1-6
hold 1-6
horizontal slider 1-6
increment and decrement 1-6
information 1-6
lead 1-5
patient 1-5
patient information 1-18
Programmer/recorder/monitor (PRM) mode
indicator 1-3
run 1-6
scrolling 1-7
snapshot 1-6
sorting 1-6
vertical slider 1-6
Impedance test, lead 5-13
Implant
post, information 6-21
Increment and decrement

icon 1-6
Indications Based Programming (IBP) 1-14
Induction, EP test 7-4
Information
icon 1-6
implant 1-18
lead 1-18
patient 1-18
Interrogate 1-9
Interval
arrhythmia logbook 6-8
coupling, ATP 3-9
minimum, burst cycle length 3-11
Intrinsic amplitude test 5-12

L

Last delivered shock 5-6
Lead
configuration 4-57
Daily measurements 5-7
icon 1-5
impedance 5-13
intrinsic amplitude 5-12
Lead status 5-7
pace threshold 5-14
test 5-11
Left ventricular protection period (LVPP) 4-70
Left ventricular refractory period (LVRP) 4-70
Logbook 6-2
Lower rate limit (LRL) 4-8
LV offset 4-13
LV VectorGuide 5-17
LV-blank after A-pace 4-72
LVAT (left ventricular automatic threshold) 4-22

M

Magnet
feature setup 6-24
inhibit tachy therapy 6-25
Maintaining cardiac resynchronization therapy
maintaining CRT 4-4
Manual programming 1-16
Manual/50 Hz burst pacing 7-7
Maximum
pacing rate 4-50
sensor rate (MSR) 4-11
tracking rate (MTR) 4-9
Maximum pacing rate
rate smoothing 4-56
Memory, device 1-19
Minimum
interval 3-11
Minute Ventilation 4-35
fitness level 4-41
response factor 4-39
Ventilatory Threshold 4-40
Ventilatory Threshold Response 4-40
Mode

Demonstration 1-8
device 2-2
electrocautery 2-2
fallback ATR (atrial tachy response) 4-48
pacing 4-6
Programmer/recorder/monitor (PRM) 1-3
temporary, EP test 7-2
ventricular tachy 2-2
MRI Protection Mode 2-3
MTR (maximum tracking rate) 4-4

N

Noise

blanking and noise rejection 4-71
Dynamic Noise Algorithm 4-28, 4-76
response 4-75

Nominal parameter setting A-1

Number of bursts 3-8
pulse count 3-8

O

Onset 2-10, 2-29, 2-31–2-32

P

Pace

STAT PACE 1-17

Pace threshold test 5-14

PaceSafe

LVAT 4-22
RAAT 4-14
RVAT 4-18

pacing

CRT (cardiac resynchronization therapy) 4-4

Pacing

adaptive-rate 4-30
amplitude 4-14
ATR mode switch 4-46
AV delay 4-61
backup during atrial stimulation 7-5
backup pacemaker in safety mode 1-20
burst, 50 Hz/manual 7-7
chamber, ventricular 4-12
Indications Based Programming (IBP) 1-14
lower rate limit (LRL) 4-8
LV offset 4-13
maximum sensor rate (MSR) 4-11
maximum tracking rate (MTR) 4-9
mode 4-6
noise response 4-75
PaceSafe LVAT 4-22
PaceSafe RAAT 4-14
PaceSafe RVAT 4-18
parameter, basic 4-5
post therapy 4-29

post-therapy 4-28
programming recommendation 4-3
pulse width 4-13
refractory 4-66
runaway protection 4-12
sensitivity 4-25
sensor 4-43
SmartDelay optimization 4-64
temporary 4-29
therapy 4-2

Package

symbol on B-1

Patient

information icon 1-5

Patient Information 1-18

Patient triggered monitor 6-21

PES (programmed electrical stimulation) 7-6

PMT (pacemaker-mediated tachycardia) termination
4-51

Polarity

shock 3-17

Post implant information 6-21

beeper feature 6-22
magnet feature 6-24

Post-shock

detection parameter 2-12

duration 2-16

pacing 4-29

Post-therapy pacing 4-28

Premature ventricular contraction (PVC) 4-68

Prescription

therapy 3-2

Print

report 1-19

Printer

external 1-19

Program 1-14

Programmable option, parameter A-1

Programmer/recorder/monitor (PRM) 1-2

controls 1-2, 1-16

Demonstration mode 1-8

modes 1-3

software terminology 1-2

use of color 1-7

Programming recommendation 1-14, 1-16, 4-3

Protection

period, left ventricular (LVPP) 4-70

runaway 4-12

Pulse amplitude 4-14

Pulse count 3-8

Pulse generator (PG)

memory 1-19

replacement indicators 5-3

Pulse width 4-13

ATP (antitachycardia pacing) 3-13

PVARP (post ventricular atrial refractory period) 4-66

after PVC (premature ventricular contraction) 4-68

dynamic PVARP 4-67

PVC (premature ventricular contraction) 4-68

Q

QUICK CONVERT ATP 3-14
Quit
 ending a telemetry session 1-9

R

RAAT (right atrial automatic threshold) 4-14
Radio frequency (RF)
 interference 1-12
 operating temperature, telemetry 1-10, 1-12
 starting telemetry 1-9
 telemetry 1-8

Ramp scheme 3-11

Ramp/Scan scheme 3-12

Rate

 adaptive 4-30
 AFib threshold 2-25
 calculation 2-5
 lower limit (LRL) 4-8
 maximum sensor 4-11
 maximum tracking 4-9
 sensing 2-4
 sustained rate duration (SRD) 2-30
 threshold, ventricular 2-5
 V rate > A rate 2-24
 ventricular 2-5
 zone 2-5

Rate adaptive pacing 4-30

Rate enhancement, pacing

 rate hysteresis 4-53
 rate smoothing 4-54
 tracking preference 4-52

Rate Hysteresis 4-53

 hysteresis offset 4-53
 search hysteresis 4-53

Rate smoothing 4-54

 down 4-56
 Maximum pacing rate 4-56
 up 4-55

Rate threshold, ATR 4-47

Reaction time 4-33

Read data 1-18

Reconfirmation 2-11, 3-18

Recovery time 4-34

Red warning conditions 1-7

Redetection 2-11

 after ATP delivery 2-16, 3-6
 after shock delivery 2-16, 3-7
 duration 2-16
 ventricular 3-6

Reform, capacitor 5-6

Refractory

 atrial, post ventricular (PVARP) 4-66
 atrial, same chamber 4-69
 blanking and noise rejection 4-71
 left ventricular (LVRP) 4-70
 left ventricular protection period 4-70
 PVARP after PVC 4-68
 right ventricular (RVRP) 4-69

Refractory; pacing

 refractory 4-66

Replacement Indicators 5-3

Report, printed 1-3, 1-18

 ECG/EGM 1-3

Response factor, accelerometer 4-31

Response Factor, Minute Ventilation 4-39

Rhythm

 ID, automatic intrinsic 2-8

RhythmMatch Threshold 2-22

Right ventricular refractory (RVRP) 4-69

RightRate Pacing 4-35

Run

 icon 1-6

Runaway protection 4-12

RV-blank after A-pace 4-71

RVAT (right ventricular automatic threshold) 4-18

S

Safety core 1-20

Safety mode 1-20

Safety Tachy Mode 1-21

Save data 1-18

Scan scheme 3-12

Screen, programmer application 1-2

Scrolling

 icon 1-7

Security

 ZIP telemetry 1-10, 1-12

Sensing, rate 2-4

Sensitivity 4-25

 AGC (automatic gain control) 4-26

Sensor and trending, pacing 4-43

 accelerometer 4-31

 adaptive-rate 4-30

 maximum sensor rate (MSR) 4-11

 minute ventilation 4-35

 SmartDelay optimization 4-64

Setting

 parameter value A-1

 zone configuration 2-5

Shock

 charge time, energy 3-16, 5-6

 commanded, EP test 7-8

 committed 3-18

 diverting 1-16

 energy 3-15

 impedance 5-13

 last delivered 5-6

 on T induction 7-5

 polarity 3-17

 post-shock pacing 4-29

 redetection 2-16

 selection 3-3

 sequence 3-2

 STAT SHOCK 1-16

 therapy 3-15

 ventricular therapy 3-15

 waveform 3-17

Shock if unstable 2-28

Shock on T induction 7-5

SmartDelay optimization 4-64

Snapshot 6-8
icon 1-6
Software terminology 1-2
Sorting
icon 1-6
Stability 2-10, 2-27, 2-30–2-32
STAT PACE 1-17
STAT SHOCK 1-16
Stimulation, PES induction 7-6
Stored EGM
arrhythmia logbook 6-5
Sustained rate duration (SRD) 2-30
Symbol
on package B-1

Timing
blanking 4-70
left ventricular protection period (LVPP) 4-70
PVARP after PVC 4-68
Timing, pacing 4-66
Toolbar 1-5
Tracking preference 4-52
Trending
sensor 4-43
Trends 6-14
AP scan 6-16
ApneaScan 6-16
minute ventilation sensor 6-17
respiratory rate 6-16
respiratory sensor 6-17, 6-19

T

Tabs, software 1-5
Tachy mode 2-2
Safety Mode 1-21
Tachyarrhythmia
detection 2-2
detection in safety mode 1-21
Indications Based Programming (IBP) 1-15
therapy 3-2
therapy in safety mode 1-21
zone 2-5
Telemetry
ending a telemetry session 1-9
operating temperature, ZIP 1-10, 1-12
starting ZIP 1-9
wand 1-8
wanded 1-9
ZIP 1-8
Temporary
pacing 4-29
Test
EP (electrophysiologic) 7-2
intrinsic amplitude 5-12
lead 5-11
lead impedance 5-13
pace threshold 5-14
Therapy
ATP (antitachycardia pacing) 3-7
pacing 4-2
post-shock pacing 4-29
prescription 3-2
selection 3-3
shock 3-15
tachyarrhythmia 3-2
tachyarrhythmia, safety mode 1-21
Therapy history 6-2
arrhythmia logbook 6-2
counter 6-10
heart rate variability (HRV) 6-11
histogram 6-9
patient triggered monitor 6-21
Threshold
AFib rate 2-25
rate 2-5
Threshold, activity 4-32
Time-out, ATP 3-13

U

Upper Rate Behavior 4-9
USB 1-18

V

V rate > A rate 2-24
Vector timing and correlation 2-22, 2-30
RhythmMatch Threshold 2-22
VectorGuide (LV) 5-17
Ventilatory Threshold 4-40
Ventilatory Threshold Response 4-40
Ventricular
ATP (antitachycardia pacing) 3-7
detection, tachyarrhythmia 2-7
redetection after ventricular ATP therapy 3-6
redetection after ventricular shock therapy 3-7
redetection after ventricular therapy delivery 3-6
shock therapy 3-15
tachy mode 2-2
tachyarrhythmia therapy 3-2
Ventricular pacing chamber 4-12
Ventricular rate regulation 4-49
maximum pacing rate 4-50
Ventricular shock vector 3-15
Vertical slider
icon 1-6
VFib induction 7-4
VTR (ventricular tachy response) 4-49

W

Wand, telemetry 1-2, 1-8–1-9
Warning conditions, red 1-7
Waveform, shock 3-17
Wenckebach 4-4, 4-54
Window
detection 2-12

Y

Yellow attention conditions 1-7

Z

ZIP telemetry 1-8

advantages 1-9

indicator light 1-9

interference 1-12

operating temperature 1-10, 1-12

radio frequency (RF) 1-9

security 1-10, 1-12

session 1-9

Zone

cardiac resynchronization therapy (CRT) delivery
2-6

configuration 2-5

ventricular 2-5

ventricular tachyarrhythmia 2-5

ZOOM LATITUDE Programming System

components 1-2

ZOOMVIEW Software Application 1-2

purpose 1-2

screens and icons 1-2

use of color 1-7

Остаряла версія. Не се използва.
Zastarjela verzija. Ne koristite.
Forældret version. Do not use.
Version obsolet. Ne použijte.
Version obsolete. Ne utilizez.
Aegunnu versjón. Annið kasutage.
Παλιά έκδοση. Μην την χρησιμοποιείτε.
Outdated version. Do not use.
Versión obsoleta. No utilizar.
Zastarjela verzija. Nemojte upotrebljavati.
Version périmée. Ne pas utiliser.
Úreilt útgáfa. Notið ekki.
Versione obsoleta. Non utilizzare.
Pasenusi verzija. Neizmantot.
Elavult versio. Nenaudokite.
Dit is een verouderde versie. Niet gebruiken.
Wersja przeterminowana. Nie używać.
Versão obsoleta. Não utilize.
Versione expirată. Nu se utilizează.
Zastaraná verzia. Nepoužívať.
Vanhentunut versio. Älä käytä.
Föråldrad version. Använd ej.
Güncel olmayan sürüm. Kullanmayın.

Остаряла версия. Да не се използва.
Zastaralá verze. Nepoužívat.
Forældet version. Må ikke anvendes.
Version überholt. Nicht verwenden.
Aegunud versioón. Ærge kasutage.
Παλιά έκδοση. Μην την χρησιμοποιείτε.
Outdated version. Do not use.
Versión obsoleta. No utilizar.
Zastarjela verzija. Nemojte upotrebljavati.
Úreilt útgáfa. Notið ekki.
Versione obsoleta. Ne pas utiliser.
Novecojsi versija. Non utilizzare.
Pasenusi versija. Neizmantot.
Elavult verzió. Ne használja!
Dit is een verouderde versie. Niet gebruiken.
Wersja przeterminowana. Nie używać.
Versão obsoleta. Não utilize.
Versiune expirată. A nu se utiliza.
Zastaraná verzia. Nepoužívať.
Vanhentunut versio. Älä käytä.
Föråldrad version. Använd ej.
Güncel olmayan sürüm. Kullanmayın.

Остаряла версия. Да не се използва.
Zastaralá verze. Nepoužívat.
Forældet version. Må ikke anvendes.
Version überholt. Nicht verwenden.
Aegunud versioón. Myn þyn χρησιμοποιείτε.
Παλιά έκδοση. Μην την χρησιμοποιείτε.
Outdated version. Do not use.
Versión obsoleta. No utilizar.
Zastarjela verzija. Nemojte upotrebljavati.
Úreilt útgáfa. Notið ekki.
Versione obsoleta. Ne pas utiliser.
Zastarjela verzija. Nenaudokite.
Novecojsi versija. Non utilizzare.
Elavult verzió. Ne használja!
Dit is een verouderde versie. Niet gebruiken.
Wersja przeterminowana. Nie używać.
Versão obsoleta. Não utilize.
Versione expiratá. A nu se utiliza.
Zastaraná verzia. Nepoužívať.
Vanhentunut versio. Älä käytä.
Föråldrad version. Använd ej.
Güncel olmayan sürüm. Kullanmayın.



Boston Scientific Corporation
4100 Hamline Avenue North
St. Paul, MN 55112-5798 USA

EC REP

Guidant Europe NV/SA; Boston Scientific
Green Square, Lambroekstraat 5D
1831 Diegem, Belgium

www.bostonscientific.com

1.800.CARDIAC (227.3422)

+1.651.582.4000

© 2017 Boston Scientific Corporation or its affiliates.

All rights reserved.

359406-035 EN Europe 2017-11

CE0086

Authorized 2013 (AUTOGEN, DYNAGEN, INOGEN, ORIGEN); 2010
(INCEPTA, ENERGEN, PUNCTUA)

Products no longer placed on the EU market but continue to be
supported. 2008 (COGNIS)

