

RAPIDO® Cut-Away® Guiding Catheter System

CAREFULLY READ ALL INSTRUCTIONS PRIOR TO USE.

CAUTION: Federal (USA) law restricts this device to sale, distribution, and use by or on the order of a physician.

HOW SUPPLIED

STERILE. Bleedback control valve, rotating hemostasis valve, and cutter sterilized with electron beam radiation. Guiding catheter sterilized with ethylene oxide gas. Non-pyrogenic. Do not use if the package is open or damaged.

SYSTEM COMPONENTS. One (1) Guiding Catheter; One (1) 0.185" Bleedback Control Valve (7568) or One (1) 0.185" Rotating Hemostasis Valve (7565); One (1) Cutter (7566); One (1) commercially available Luer Lock Stopcock.

Figure 1.0

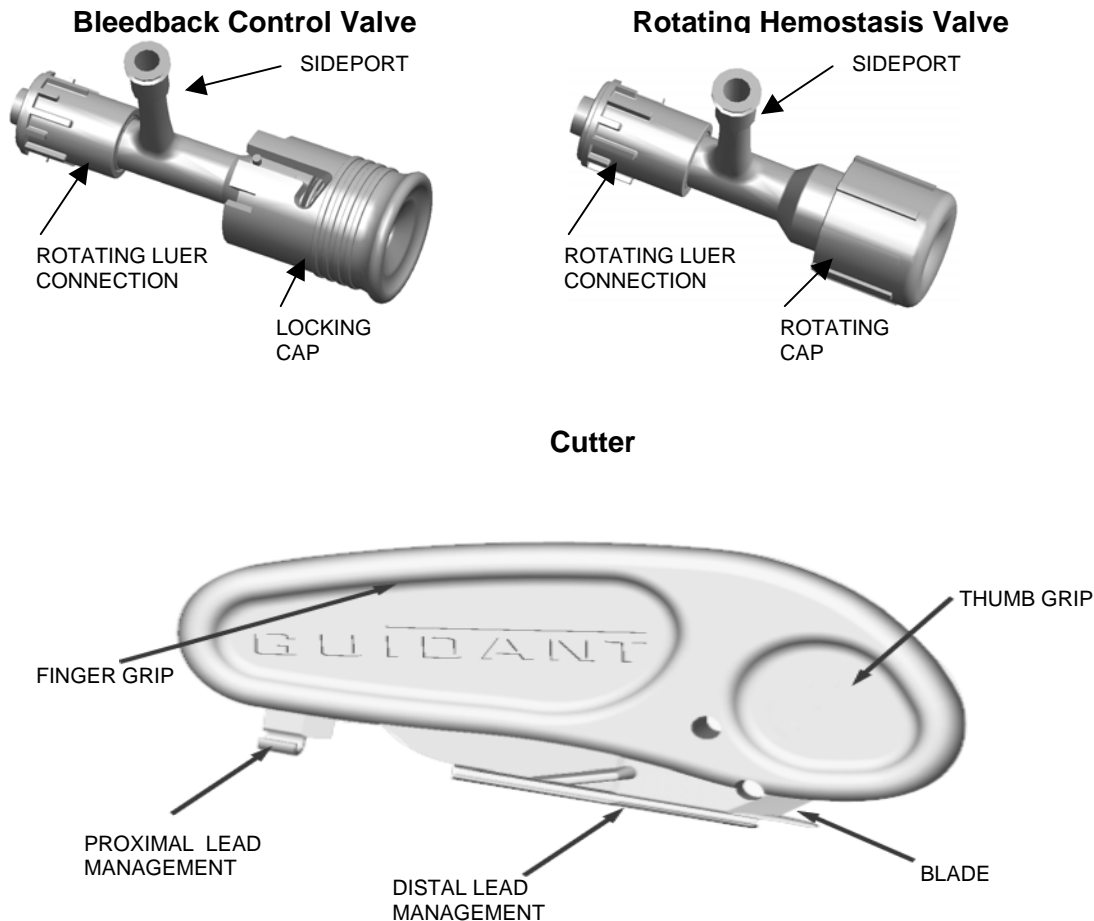

Guiding Catheter

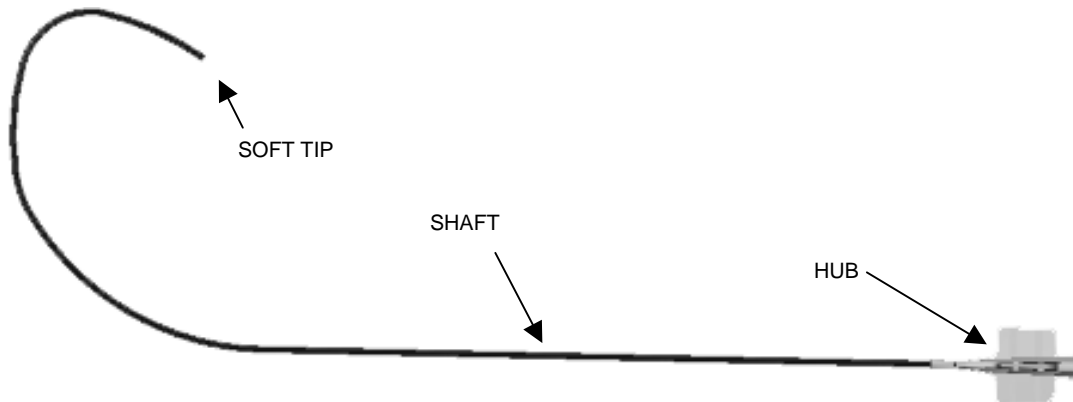

STORAGE. Store in a dry, dark, cool place.

INDICATIONS

The Guidant RAPIDO® Cut-Away® Guiding Catheter is intended to access the coronary venous system, and may be used as a dual-catheter assembly. The catheter serves as a conduit for the delivery of contrast medium and devices, including implantable coronary venous leads, introduced into the coronary venous system.

The Guidant Rotating Hemostasis Valve is intended for maintaining a fluid-tight seal around devices, including implantable coronary venous leads, during the implant procedure.

The Guidant Bleedback Control Valve is intended for maintaining a seal around diagnostic / interventional devices with an outside diameter of less than 0.185" in the venous anatomy only, during interventional procedures.

The Guidant Cutter is intended to facilitate RAPIDO® Cut-Away® Guiding Catheter removal after the Guidant coronary venous lead is positioned.

INTENDED USE

The Guidant RAPIDO® Cut-Away® Guiding Catheter is intended to be used with the Guidant Bleedback Control Valve or Rotating Hemostasis Valve, a Guidant Cutter, and a commercially available luer lock stopcock.

CONTRAINDICATIONS

The Guidant Bleedback Control Valve is not intended for use with pressure injections of greater than 30 psi.

WARNINGS

These devices are distributed STERILE, NON-PYROGENIC and is intended for one time use only. Do NOT resterilize and / or reuse it, as this can potentially result in compromised device performance and risk of inappropriate sterilization and cross contamination.

Sideholes should not be placed in the shaft of the guiding catheter by the user. Puncturing the shaft of the guiding catheter with hospital instruments may lead to thrombogenesis or failure of shaft integrity.

When this guiding catheter is in the body, it should be manipulated while under high-quality fluoroscopic observation.

PRECAUTIONS

Prior to use, the guiding catheter, bleedback control valve or rotating hemostasis valve, cutter, and stopcock, should be examined to verify functionality and ensure that its size and shape are suitable for the specific procedure for which it is to be used.

It is recommended that a guide wire be used to advance the guiding catheter into the venous system, right atrium or coronary sinus.

PREPARATION FOR USE

1. Remove components from the sterile packaging and place on sterile flat surface. Set Cutter(s) off to the side for later use.
2. Attach the hemostasis valve of choice to the guiding catheter proximal hub. Attach the stopcock to the side arm of the hemostasis valve, with the stopcock closed.
3. Attach a 10 – 12 cc luer lock syringe filled with sterile heparinized normal saline to the Stopcock.
 - a. If using a Bleedback Control Valve:
 - i. Open the bleedback control valve by pushing on the cap and rotating it clockwise to the locked open position.
 - ii. Place finger over the distal guiding catheter tip, and flush until fluid fills and exits the bleedback control valve cap.
 - iii. Rotate the cap counterclockwise to unlock and return the valve to a closed position. (See Figure 2.0 for locked and unlocked position).
 - iv. Remove finger from the distal guiding catheter tip and continue to flush until fluid exits the distal tip of the guiding catheter.
 - v. Turn stopcock lever to a closed position.

Figure 2.0

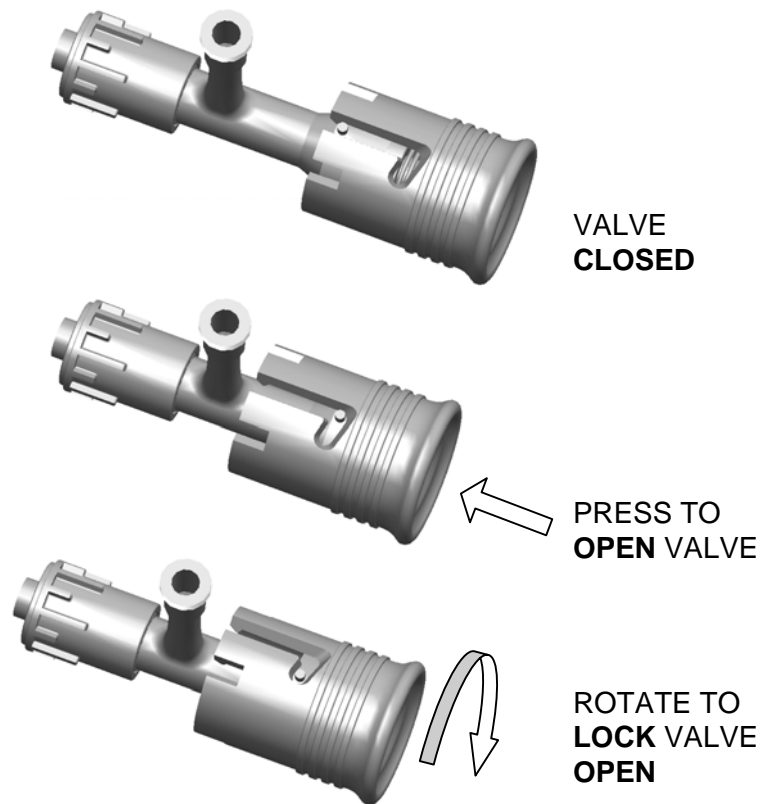

b. If using a Rotating Hemostasis Valve:

- i. Open the rotating hemostasis valve by rotating the cap in a counterclockwise direction.
- ii. Place finger over the distal guiding catheter tip, and flush until fluid fills and exits the rotating hemostasis valve cap.
- iii. Rotate the cap clockwise to a closed position.
- iv. Remove finger from the distal guiding catheter tip, and continue to flush until fluid exits the distal tip of the guiding catheter.
- v. Turn stopcock lever to a closed position.

DIRECTIONS FOR USE

1. Prior to inserting the guiding catheter assembly, verify that the hemostasis valve is closed, and that the distal rotating luer is securely attached to the guiding catheter. Insert the guiding catheter assembly into an introducer, using the vessel entry technique of choice.
2. Advance the guiding catheter assembly to the vascular site. Obtain a stable position with the guiding catheter. If a contrast injection is desired, attach a 10 - 12 cc contrast filled luer lock syringe to the stopcock.
3. Insert the desired device(s) into the guiding catheter through the hemostasis valve.
 - a. If using the Bleedback Control Valve:
 - i. Slightly compress the cap when introducing a device.
 - ii. Release the cap to its normal position to maintain hemostasis while advancing a device.
 - b. If using the Rotating Hemostasis Valve:
 - i. Rotate the cap counterclockwise to introduce and advance a device.
 - ii. Once the device is in position, close the rotating hemostasis valve by rotating the cap clockwise. Only tighten enough to maintain hemostasis.
4. Prior to removing the guiding catheter, ensure the finishing wire is in place.
5. Disconnect the hemostasis valve from the guiding catheter.
 - a. If using a Bleedback Control Valve:
 - i. Open the bleedback control valve by pushing on the cap and rotating it clockwise to the locked open position.
 - ii. Secure the guiding catheter hub in one hand. Loosen the rotating luer connection with the other hand by rotating it counterclockwise until it is freed from the guiding catheter hub.
 - iii. Maintaining the lead position at all times, slide the bleedback control valve carefully over the proximal end of the lead and finishing wire assembly.

- b. If using a Rotating Hemostasis Valve:
 - i. Open the rotating hemostasis valve by rotating the cap counterclockwise.
 - ii. Secure the guiding catheter hub in one hand. Loosen the rotating luer connection with the other hand by rotating it counterclockwise until it is freed from the guiding catheter hub.
 - iii. Maintaining the lead position at all times, slide the rotating hemostasis valve carefully over the proximal end of the lead and finishing wire assembly.
- 6. Cutting the guiding catheter:
 - a. Attach the distal lead management portion of the cutter to the proximal lead body as close to the guiding catheter hub as possible.
 - b. Attach the lead to the proximal lead management portion of the cutter. (See Figure 3.0 for cutter attachment.)

Figure 3.0

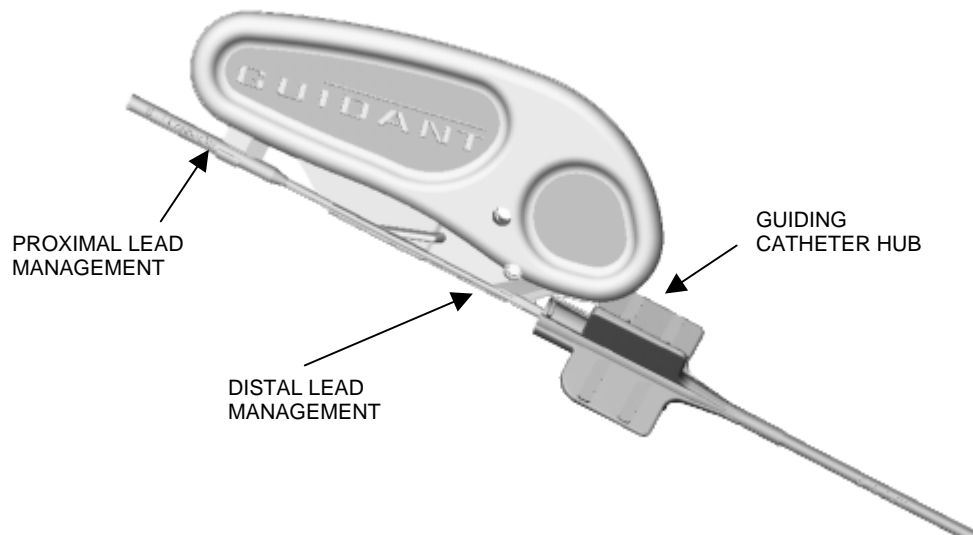

- c. Hold the cutter / lead / finishing wire assembly securely with one hand. Grasp the guiding catheter hub with the other hand. **DO NOT PUSH FORWARD WITH THE CUTTER / LEAD ASSEMBLY, MAINTAIN A FIXED POSITION ON A STABLE SURFACE, AND PULL BACK THE GUIDING CATHETER HUB.**
- d. Pull the guiding catheter hub across the cutter blade and away from the lead until the guiding catheter is completely cut.
- e. Once the lead is visualized and the guiding catheter has been completely removed, set the guiding catheter aside.







- f. While maintaining a secure hold on the lead distal to the cutter, carefully remove the lead from the cutter.
- g. While observing under fluoroscopy, carefully remove the finishing wire, verifying final lead position.

Guidant Corporation
4100 Hamline Avenue North
St. Paul, MN 55112-5798 USA

24-Hour Consultation
1-800-CARDIAC (1-800-227-3422)
Worldwide: 651-582-4000
www.guidant.com

© 2004, Guidant Corporation

**Graphical Symbols For
Medical Device Labeling**

| | | | |
|--|--|---------|----|
|  Manufacturer | <table border="1"><tr><td>STERILE</td><td>R</td></tr></table> Sterilized using Irradiation | STERILE | R |
| STERILE | R | | |
| REF Catalogue Number | <table border="1"><tr><td>STERILE</td><td>EO</td></tr></table> Sterilized using Ethylene Oxide | STERILE | EO |
| STERILE | EO | | |
| F French Size |  Date of Manufacture | | |
|  Consult Instructions for Use |  Use By | | |
|  Contents (Numeral represents quantity of units inside.) | <table border="1"><tr><td>LOT</td></tr></table> Batch Code | LOT | |
| LOT | | | |
|  Do Not Reuse | | | |