

Automobile “Smart Key” Systems and Implantable Pacemakers and Defibrillators

SUMMARY

This article describes the smart key system available in many automobiles, and provides information regarding its use around pacemaker and/or defibrillator patients.

- Some vehicle makers caution that electromagnetic waves transmitted by smart key system antennas may interfere with pacemakers or defibrillators¹
- Boston Scientific testing suggests that the smart key system remote unit and/or smart key system antennas should not interfere with Boston Scientific CRM implanted pacemakers or defibrillators.
- Patients should consult with their device following physician to discuss any concerns they might have regarding the potential for interference.

CRT-D: Cardiac Resynchronization Therapy Defibrillator
 CRT-P: Cardiac Resynchronization Therapy Pacemaker
 ICD: Implantable Cardioverter Defibrillator

CRM PRODUCTS REFERENCED*

All ICD, CRT-D, CRT-P and pacing systems

*Products referenced herein may not be approved in all geographies. For comprehensive information on device operation, reference the appropriate product labeling.

CRM CONTACT INFORMATION

Technical Services – U.S.
 1.800.CARDIAC (227.3422)
Tech.Services@bsci.com

Technical Services – Europe
 +32 2 416 7222
eurtechservice@bsci.com

LATITUDE Clinician Support
 1.800.CARDIAC (227.3422)
latitude@bsci.com

Patient Services
 1.866.484.3268 – U.S. and Canada
 001.651.582.4000 – International

Smart Key Systems

Many automobiles feature an electronic “smart key” system (names differ among automobile manufacturers).² These computerized systems allow drivers to lock and unlock the doors or to start and stop the vehicle engine without the use of a traditional key.

Smart key systems operate using two-way communication between a remote unit and special antennas located within the vehicle. The remote unit transmits signals to the vehicle when certain buttons on it are manually selected (e.g., the vehicle trunk release). Signals are received by the remote unit whenever it is within the specified operating range of the smart key system antennas located within the vehicle. While within range, the continuous signals received by the smart key antennas allow certain smart key system actions to be initiated, such as the entry or engine start/stop function.

Figure 1 illustrates common locations of the smart key antennas within automobiles as well as the effective range for detection of the smart key remote unit. For example, the Toyota Camry smart key system can be operated when the remote unit is within about 0.7 m (2.3 ft) of either the outside front door handles or trunk release handle, and whenever the remote unit is inside the vehicle cabin. To determine the exact location of smart key antennas and associated detection ranges, patients should refer to the vehicle owner’s manual, or contact the vehicle manufacturer.

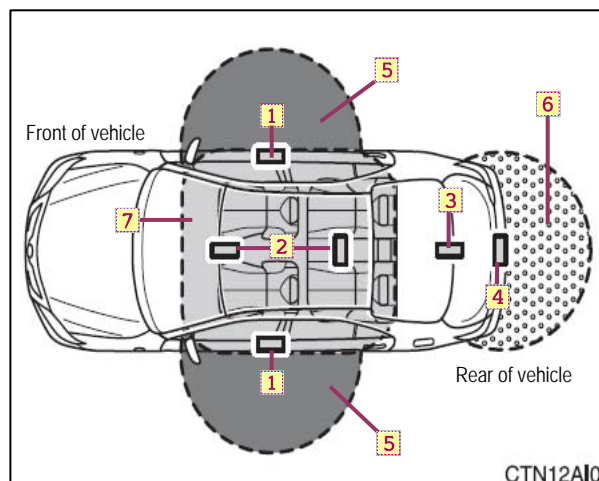

Examples of antenna locations:

- 1 Door handles
- 2 Center console and under rear seats
- 3 Trunk
- 4 Rear bumper

Examples of remote detection ranges:

- 5 When locking or unlocking the doors
- 6 When unlocking the trunk
- 7 When starting the engine

Figure 1. Example of antennae locations and the effective range for smart key system remote unit detection on a Toyota Camry.³

¹Toyota Camry e-brochure page. Toyota Web site. Available at <http://www.toyota.com/camry/ebrochure.html>. Accessed September 11, 2008.

²Examples of smart key systems available in various automobiles: Acura Keyless Access System; Audi Advanced Key; BMW Comfort Access; Cadillac Adaptive Remote Start and Keyless Access; Infiniti Intelligent Key with Push Button Ignition; Lexus SmartAccess System; Mercedes-Benz Keyless Go; Mitsubishi Motors FastKey; Nissan Intelligent Key; Porsche Porsche Entry & Drive System; Toyota Smart Key System; Mazda Advanced Keyless Entry & Start System; Suzuki SmartPass Keyless entry & starting system; Volvo Personal Car Communicator.

³Smart Key portion of user manual. Available at http://toyota.justanswer.com/uploads/skyvisions/2008-03-29_091613_09camry.pdf. Accessed on September 11, 2008.

Electromagnetic Interference (EMI)

Electronic devices radiate energy in the form of electromagnetic waves, which are the result of electrically and magnetically charged particles in motion. EMI occurs when electromagnetic fields from one electronic device disrupt the functioning of another electronic device. If an electronic device interferes with the operation of an implanted pacemaker or defibrillator, the effects are typically temporary and can be eliminated if the patient increases the distance between themselves and the source of EMI.

Smart Key System Evaluation

Because the smart key systems are electronic devices that transmit electromagnetic fields, many automobile manufacturers state in their product manuals and/or brochures the possibility that these systems may interfere with implanted pacemaker or defibrillators. In early 2006, a Japanese government office issued a precautionary notification (based on their own testing) to Japanese physicians, patients, and implantable device manufacturers of potential interactions between smart key systems and implantable pacemakers and defibrillators.⁴

Boston Scientific has performed testing and analysis to identify and understand potential interactions that may occur between smart key systems and Boston Scientific CRM implantable devices. Testing and analysis included representative combinations of Boston Scientific pacemakers and defibrillators and the smart key systems⁵ of various vehicle manufacturers. During this testing, Boston Scientific did not observe any type of EMI with respect to pacemaker or defibrillator function (i.e., sensing, pacing, shock therapy, and programming) as a result of smart key system operation. The test results were the same whether the vehicle engine was On or Off.

Boston Scientific evaluations suggests that a patient carrying one of these, or similar smart key system remote units in close proximity to their implanted pacemaker or defibrillator (e.g., in a shirt pocket) should not encounter interference with the operation of their implanted device. Evaluations also suggest that the signals transmitted by these or similar smart key system antennas within or on the vehicle should not interfere with the operation of Boston Scientific implantable pacemakers or defibrillators, including when a patient leans against or sits inside the vehicle.

NOTE: *Patients should consult with their device following physician to discuss any concerns they might have regarding the potential for interference. Boston Scientific cannot assure the safe and effective operation of its implantable CRM device or smart key systems when used in combination.*

⁴Pacemaker Committee, Japan Associations of Medical Equipment Industries. The effect of automobile and smart key systems on implanted cardiac pacemakers and implanted defibrillators. Available at: <http://www.pacemakercom.co.jp/pm0426.pdf>. Accessed July 2, 2008. Note that this document has been translated by Boston Scientific to be used as a reference; copies are available upon request via CRM Technical Services.

⁵Smart key systems tested or analyzed: 2007 Toyota Prius, 2007 Nissan Ultima, and 2008 Acura RL.