

# WallFlex™ Biliary RX

## Fully Covered Stent System RMV

*Prescriptive Information*

Refer to the device directions for use for complete instructions on device use.

### Caution/Rx Only:

Federal Law (USA) restricts this device to sale by or on the order of a physician.

### Warning

Contents supplied STERILE using an ethylene oxide (EO) process. Do not use if sterile barrier is damaged. If damage is found, call your Boston Scientific representative.

For single use only. Do not reuse, reprocess or resterilize. Reuse, reprocessing or resterilization may compromise the structural integrity of the device and/or lead to device failure which, in turn, may result in patient injury, illness or death. Reuse, reprocessing or resterilization may also create a risk of contamination of the device and/or cause patient infection or cross-infection, including, but not limited to, the transmission of infectious disease(s) from one patient to another. Contamination of the device may lead to injury, illness or death of the patient.

After use, dispose of product and packaging in accordance with hospital, administrative and/or local government policy.

### Intended Use/Indications for Use

The WallFlex Biliary RX Fully Covered Stent System RMV is indicated for use in the palliative treatment of biliary strictures produced by malignant neoplasms, relief of malignant biliary obstruction prior to surgery and for indwell up to 12 months in the treatment of benign biliary strictures secondary to chronic pancreatitis.

### Contraindications

The WallFlex Biliary RX Fully Covered Stent System RMV is contraindicated for:

- Placement in strictures that cannot be dilated enough to pass the delivery system.
- Placement in a perforated duct.
- Placement in very small intrahepatic ducts.
- Those patients for whom endoscopic techniques are contraindicated.

### General Warnings

Visually inspect the system for any signs of damage. DO NOT USE if the system has any visible signs of damage. Failure to observe this warning may result in patient injury.

The safety and effectiveness of this device for use in the vascular system has not been established.

Testing of overlapping stents has not been conducted.

Passing a second stent delivery system through a just deployed stent is not recommended and could cause the stent to dislodge.

Use caution when placing stent near ductal branches to avoid obstruction of duct. Placement of a fully covered biliary stent across a branch duct or major bifurcation may result in complications due to blockage of flow from the branch duct and prevent endoscopic or transhepatic access for future procedures.

A stent cannot be reconstrained after the reconstraint limit has been exceeded.

The stent contains nickel, which may cause an allergic reaction in individuals with nickel sensitivity.

### **WARNINGS FOR STENTING DUE TO MALIGNANCIES**

Careful consideration must be taken when removing a stent from an intrinsic malignant tumor. Removal may result in perforation, bleeding or tissue abrasion.

The WallFlex Biliary RX Fully Covered Stent should not be moved or removed after completion of the initial stent placement procedure in intrinsic malignant tumors. Manipulating, repositioning or removal of the stent may result in

# WallFlex™ Biliary RX

## Fully Covered Stent System RMV

*Prescriptive Information*

Refer to the device directions for use for complete instructions on device use.

perforation, bleeding, tissue abrasion or other patient injury.

### **WARNINGS FOR STENTING TO TREAT BENIGN STRICTURES SECONDARY TO CHRONIC PANCREATITIS**

Clinical Study was not able to demonstrate that the use of this device is safe and effective in the treatment of benign biliary post liver transplantation anastomotic strictures and of benign biliary post abdominal surgery strictures.

The safety and effectiveness of the stent for benign stricture treatment has not been established for indwell periods exceeding 12 months.

### **Device Description**

The WallFlex Biliary RX Fully Covered Stent System RMV consists of a flexible delivery system preloaded with a self-expanding biliary metal stent.

The stent is made from a Nitinol monofilament wire with a radiopaque platinum core that is formed into a cylindrical mesh. The WallFlex Biliary RX Fully Covered Stent is offered fully covered with Permalume® Coating, a translucent silicone polymer, to reduce the potential for tumor/tissue ingrowth through the stent (Figure 1). The WallFlex Biliary RX Fully Covered Stent has a retrieval loop for removal during the initial stent placement procedure, to be used in the event of incorrect placement and/or removal from benign strictures up to 12 months. The stent has a flare at both ends to aid in preventing migration after the stent has been placed in the bile duct. The WallFlex Biliary RX Fully Covered Stent System RMV is an RX compatible system only. The WallFlex Biliary RX Fully Covered Stent is provided sterile using ethylene oxide and is a single use device.

The delivery system is a coaxial tube design. The exterior tube is used to constrain the stent before deployment and reconstrain the stent, if stent repositioning is necessary, after partial deployment. The exterior tube has a clear section so that the constrained stent is visible. A yellow transition zone on the inner tube of the delivery system is visible between the stent and the blue outer sheath. There are four radiopaque (RO) markers to aid in the deployment of the stent while using fluoroscopy (Figure 2). There are two RO markers on the inner tube of the delivery system identifying the ends of the constrained stent (Figure 2, marker 1 and 3). Between these RO markers is an additional RO marker that indicates at what point reconstraint is no longer possible (Figure 2, marker 2). The fourth RO marker at the leading end of the exterior tube indicates how far the stent has been deployed (Figure 2, marker 4). There is one visual marker on the interior tube between the handles to aid in the deployment of the stent (Figure 2, marker 5). The visual marker indicates the point at which reconstraint is no longer possible. The interior tube has a single central lumen to accommodate a 0.035 in (0.89 mm) guidewire.

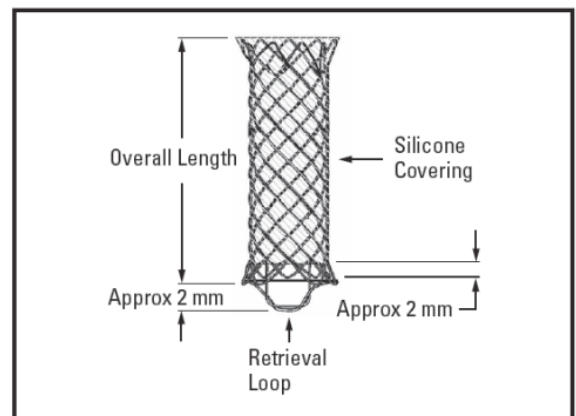

Figure 1. WallFlex Biliary RX Fully Covered Stent

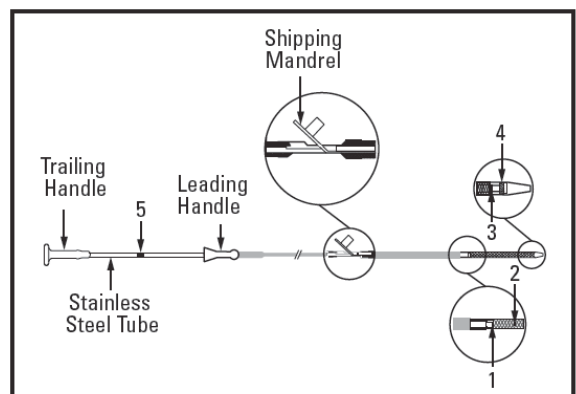

Figure 2. WallFlex Biliary RX Stent System RMV

# WallFlex™ Biliary RX

## Fully Covered Stent System RMV

*Prescriptive Information*

Refer to the device directions for use for complete instructions on device use.

### MRI Safety Information

MR Conditional - Non-clinical testing has demonstrated that the WallFlex Biliary RX Stent(s) are MR Conditional. A patient with this device can be safely scanned under the following conditions:

- Static magnetic field of 1.5 T and 3.0 T
- Maximum spatial gradient magnetic field of 3,000 gauss/cm (30 T/m)
- Maximum MR system reported, whole body averaged specific absorption rate (SAR) of < 4.0 W/kg (First Level Controlled Operating Mode)

Under the scan conditions defined above, the WallFlex Stent(s) are expected to produce temperature rise of less than 5.5 °C after 15 minutes of continuous scanning.

In non-clinical testing, the image artifact caused by the device extends approximately 2 mm from the ends and 10 mm beyond the perimeter of the WallFlex Biliary RX Stent(s) when imaged with a gradient echo pulse sequence in a 3T MRI System. The image artifact does obscure the device lumen.

### Contents

One (1) WallFlex Biliary RX Fully Covered Stent System RMV.

### Potential Complications

The following complications have been reported in the literature for biliary prostheses or have been observed in the Boston Scientific clinical trials of this device when used in the treatment of biliary strictures produced by malignant neoplasms, relief of malignant biliary obstruction prior to surgery and for the treatment of benign biliary strictures secondary to chronic pancreatitis.

#### **General Potential Complications Associated with Metal Stent Placement**

These include, but are not limited to:

- Pain
- Bleeding
- Fever
- Nausea
- Vomiting
- Infection
- Inflammation
- Stent occlusion
- Mucosal hyperplasia
- Cholangitis
- Cholecystitis
- Pancreatitis
- Ulceration of duodenum or bile duct

# WallFlex™ Biliary RX

## Fully Covered Stent System RMV

*Prescriptive Information*

Refer to the device directions for use for complete instructions on device use.

- Perforation of duodenum or bile duct
- Stent migration
- Death (other than due to normal disease progression)
- Stent misplacement
- Perforation of the gallbladder due to the stent covering the cystic duct
- Stent Fracture
- Hepatic abscess

### **Additional Potential Complications Associated with Metal Stent Placement for Palliation of Malignancies**

- Tumor overgrowth around ends of stent
- Tumor ingrowth through the stent

Potential Complications Associated with Stent Removal when Used to Palliate Malignancies (refer to Warnings)

### **These include but are not limited to:**

- Pain
- Bleeding
- Fever
- Nausea
- Vomiting
- Infection
- Inflammation
- Recurrent obstructive jaundice
- Mucosal hyperplasia
- Cholangitis
- Cholecystitis
- Pancreatitis
- Ulceration of duodenum or bile duct
- Perforation of duodenum or bile duct
- Death (other than due to normal disease progression)
- Impaction to the common bile duct wall

# WallFlex™ Biliary RX

## Fully Covered Stent System RMV

Prescriptive Information

Refer to the device directions for use for complete instructions on device use.

**Potential Complications Associated with Stent Removal when Used to Treat Benign Strictures are Detailed in the Clinical Study Overview Below**

### Cautions

Excessive force should not be used to position or deploy the stent. This may cause inadvertent damage to the device and/or endoscope.

The sterile packaging and device should be inspected prior to use. If sterility or performance of the device is suspected to be compromised, it should not be used.

## CLINICAL STUDY RESULTS FOR BENIGN BILIARY STRICTURE

### TREATMENT SECONDARY TO CHRONIC PANCREATITIS USING THE WALLFLEX BILIARY FULLY COVERED STENT CLINICAL STUDY OVERVIEW

#### Objective and Endpoints

A prospective, nonrandomized clinical trial was conducted to determine the effectiveness and safety of WallFlex Biliary Fully Covered Stent in the treatment of benign biliary stricture secondary to chronic pancreatitis (CP), post-liver transplant (OLT), and post-abdominal surgery (CCY). The stent was scheduled to be removed 10-12 months after implant for CP and CCY patients and 5 months for OLT patients. The primary endpoint was stent removability. The primary endpoint performance goal was that the observed and expected success levels would be 85% and 93% respectively based on an assessment of 310 cases in the literature.

Secondary endpoints included stricture resolution during stent indwell, stricture resolution after stent removal; occurrence of serious adverse events (SAEs), ability to deploy the stent in satisfactory position across the stricture (technical success at placement), length of stent placement and removal procedures, biliary obstructive symptom assessment during the study, and liver function tests (LFTs) during the study.

Study patients were required to meet the following patient selection criteria:

#### Inclusion Criteria

- Age 18 or older
- Willing and able to comply with the study procedures and provide written informed consent to participate in the study
- Chronic pancreatitis or prior liver transplantation or prior other abdominal surgery (to include cholecystectomy)
- Indicated for ERCP procedure with stent placement for:
  - Symptomatic bile duct stricture (i.e. obstructive jaundice, persistent cholestasis, acute cholangitis) confirmed by cholangiogram and/or
  - Bile duct stricture confirmed by cholangiogram and/or
  - Exchange of prior plastic stent(s) for management of benign stricture

#### Exclusion Criteria

- Placement of the stent in strictures that cannot be dilated enough to pass the delivery system
- Placement of the stent in a perforated duct
- Placement of the stent in very small intrahepatic ducts
- Patients for whom endoscopic techniques are contraindicated

# WallFlex™ Biliary RX

## Fully Covered Stent System RMV

*Prescriptive Information*

Refer to the device directions for use for complete instructions on device use.

- Biliary stricture of malignant etiology
- Biliary stricture of benign etiology other than chronic pancreatitis or liver transplant anastomosis or other abdominal surgery
- Stricture within 2 cm of duct bifurcation
- Symptomatic duodenal stenosis (with gastric stasis)
- Prior biliary self-expanding metal stent
- Suspected stricture ischemia based on imaging of hepatic artery occlusion or endoscopic evidence of biliary cast syndrome
- Known bile duct fistula
- Known sensitivity to any components of the stent or delivery system
- Participation in another investigational study within 90 days prior to consent or during the study

#### Additional Specific to Chronic Pancreatitis Patients

- Developing obstructive biliary symptoms associated with an attack of acute pancreatitis

#### Additional Specific to Post-Abdominal Surgery Patients

- History of hepatectomy
- History of liver transplant

#### Additional Specific to Liver Transplant Patients

- Live donor transplantation

Based on the study results, the intended use of the WallFlex Biliary RX Fully covered Stent System is limited to benign biliary strictures in patients secondary to chronic pancreatitis (CP).

## Warning

Clinical Study was not able to demonstrate that the use of this device is safe and effective in the treatment of benign biliary post liver transplantation anastomotic strictures and of benign biliary post abdominal surgery strictures.

## CHRONIC PANCREATITIS STUDY COHORT INFORMATION

### Patients

One hundred and twenty-seven (127) patients with a benign biliary stricture secondary to chronic pancreatitis with either ongoing biliary obstructive symptoms or being managed for biliary obstructive symptoms were enrolled.

### Demographics

The mean age was 52.5 years (sd 10.3 years) and 104 (82%) were male. The median time since CP diagnosis was 28 months. At baseline median total bilirubin level was 0.6 mg/dl (range 0.1-22.0 mg/dl) and median alkaline phosphatase level was 201 IU/l (range 27-2371 IU/l).

The benign biliary stricture location was mostly distal, notably 115 (90.6%) were in the distal common bile duct (CBD), 2 (1.6%) in the mid CBD, 8 (6.3%) in the proximal CBD, and 2 (1.6%) were papillary.

The majority of patients had received a prior sphincterotomy (124; 97.6%) and had previously received endotherapy using plastic biliary stents (105; 82.7%). The gallbladder was in situ in 101 (79.5%) of patients.

# WallFlex™ Biliary RX

## Fully Covered Stent System RMV

*Prescriptive Information*

Refer to the device directions for use for complete instructions on device use.

### **Patient Disposition**

The intent-to-treat (ITT) patient cohort includes all 127 enrolled patients. The per protocol (PP) patient cohort has 118 patients. Nine (9) patients were excluded from the PP cohort due to; death due to unrelated causes (7), transition to palliative care in setting of pancreatic cancer (1) and withdrawal of consent (1).

Stent removability, stricture resolution and rates of SAEs were assessed for the ITT cohort (127) and PP cohort (118).

Stricture recurrence after stent removal or complete distal migration was assessed on 94 patients who reached stricture resolution.

Stent functionality during stent indwell and removal success were assessed as post-hoc analyses in the ITT and PP cohorts.

### **Stent Placement**

Five WallFlex stent sizes (diameter x length) were available and stent selection was as follows: 8 x 60 mm (4; 3.1%), 8 x 80 mm (0; 0%), 10 x 40 mm (78; 61.4%), 10 x 60 mm (43; 33.9%), and 10 x 80 mm (2; 1.6%). Technical success at stent placement was attained in 100% (127/127) of patients. Mean procedure duration was 26.6 min (sd 21.0 min).

### **Stent Migration**

Stent migration in the course of the study was reported in 19 of 127 patients. The migration was proximal – in the direction of the liver – in 7 cases (37%), was partial distal – in the direction of the duodenum but still inside of the common bile duct – in 7 cases (37%), and was complete distal – completely out of the common bile duct – in 5 cases (26%). The 19 migrations were observed a median of 318 days (range 60-1140 days) after stent placement.

### **Stent Removability**

Stent removability is defined as the ability to remove the stent endoscopically after 10-12 months without serious stent removal related adverse events as assessed from the time of stent removal to one (1) month post-stent removal.

Stent removability was successful in 72.4% (92/127) ITT patients and 78.0 (92/118) PP patients.

A summary of the subjects classified as failures is given below:

- Seven (7) deaths due to unrelated causes (ITT only)
- One (1) transition to palliative care in setting of pancreatic cancer (ITT only)
- One (1) withdrew consent (ITT only)
- Thirteen (13) early endoscopic removal
- Four (4) loss to follow-up
- One (1) surgery for progression of CP
- Three (3) stent removal related SAEs
- Three (3) spontaneous stent migration without restenting
- Two (2) spontaneous stent passage with immediate restenting

# WallFlex™ Biliary RX

## Fully Covered Stent System RMV

*Prescriptive Information*

Refer to the device directions for use for complete instructions on device use.

### Removal Success

Removal success is defined as either scheduled endoscopic stent removal with no removal-related serious adverse events (SAEs), or spontaneous stent passage without the need for immediate restenting. Removal success was achieved in 84.3% (107/127) ITT patients and 90.7% (107/118) PP patients after stent indwell ranging from 8 to 613 days. Forceps/graspers and/or a snare were used in all but one case in which a stent-in-stent technique was used for endoscopic removal of the WallFlex stents.

A summary of the subjects classified as failures is given below:

- Four (4) patients experienced removal-related serious adverse events including three (3) cases of cholangitis and one (1) case of abdominal pain.
- Stent removal was not indicated in nine patients (9) due to death (7), transition to palliative care in setting of pancreatic cancer (1) and withdrawal of consent (1) (ITT only).
- Attempts were not made in five (5) patients due to loss to follow up (4) and surgery for CP progression (1).
- Two (2) patients experience complete distal stent migration that required immediate restenting.

Note: Stent-in-Stent removal as a technique for removal of biliary self-expanding metal stents was described in peer-reviewed publications<sup>1-3</sup>. In total, the three references report on 7 cases. The authors concluded that the stent-in-stent technique is effective when difficulties are encountered during self-expanding metal stent removal due to stent migration or hyperplastic stent ingrowth or overgrowth.

### REFERENCES

1. Tan DM, Lillemoe KD, Fogel EL. A new technique for endoscopic removal of uncovered biliary self-expandable metal stents: stent-in-stent technique with a fully covered biliary stent. *Gastrointest Endosc* 2012;75:923–5.
2. Menon S. Removal of an embedded covered biliary stent by the stent-in-stent technique. *World J Gastroenterol* 2013;19:6108–9.
3. Tringali A, Blero D, Boskoski I, Familiari P, Perri V, Devière J, Costamagna G. Difficult removal of fully covered Self Expandable Metal Stents (SEMS) for benign biliary strictures: The “SEMS in SEMS” technique. *Dig and Liver Dis* 2014; 46: 568-71.

### Stent Functionality During Stent Indwell

Stent functionality during stent indwell is defined as lack of required reintervention during intended indwell or spontaneous stent passage without the need for immediate restenting within 6 days. Stent functionality during stent indwell was obtained in 77.2% (98/127) ITT patients and in 83.1% (98/118) PP patients.

A summary of the subjects classified as failures is given below:

- Seven (7) deaths due to unrelated causes (ITT only)
- One (1) transition to palliative care in setting of pancreatic cancer (ITT only)
- One (1) withdrew consent (ITT only)
- Thirteen (13) early endoscopic removal
- Four (4) loss to follow-up
- Two (2) spontaneous stent passage with immediate restenting
- One (1) surgery for progression of CP



# WallFlex™ Biliary RX

## Fully Covered Stent System RMV

*Prescriptive Information*

Refer to the device directions for use for complete instructions on device use.

### Stricture Resolution

Stricture resolution is defined by the lack of stricture-related re-intervention.

At the end of indwell, stricture resolution without the need for restenting was achieved in 74.0% (94/127) ITT patients and in 79.7% (94/118) PP patients.

A summary of the subjects classified as failures is given below:

- Nine (9) not indicated for removal due to death (7), transition to palliative care in setting of pancreatic cancer (1) and withdrawal of consent (1) (ITT only)
- Nine (9) immediate restenting after scheduled removal
- Eight (8) immediate restenting after early removal
- Four (4) loss to follow-up
- Two (2) spontaneous stent passage with immediate restenting
- One (1) surgery for progression of CP

### Stricture Recurrence

Stricture recurrence is defined by the need for stricture related re-intervention post-stent removal. Over a median follow-up period of 19.0 months (range 0.9– 29.7 months) after stent removal, 85.1% (80/94) ITT patients and 85.1% (80/94) PP patients with stricture resolution at time of removal did not experience stricture recurrence.

A summary of the subjects classified as failures is given below:

- Ten (10) patients had strictures re-occur
- Four (4) patients were lost to follow-up

### Biliary Obstructive Symptoms

Biliary obstructive symptoms were right upper quadrant pain, fever, jaundice, itching, dark urine, pale stool, and nausea. The number of patients with any symptom out of patients with visit data were considered.

Baseline: 51.2% (65/127), Indwell month 1: 16.3% (20/123), Indwell month 3: 8.6% (10/116), Indwell month 6: 6.3% (7/112), Indwell month 9: 7.8% (8/102), Stent removal: 12.8% (14/109), Post-removal month 3: 7.0% (6/86), Post-removal month 6: 16.1% (14/87), Post-removal month 12: 9.7% (7/72), Post-removal month 24: 6.2% (2/33)

### Liver Function Tests

Bilirubin levels and alkaline phosphatase levels were measured at visits from baseline to 24 months post-removal. Reported are the mean  $\pm$  standard deviation (number of patients) bilirubin level in mg/dl and alkaline phosphatase level in U/l.

Bilirubin: Baseline:  $1.6 \pm 3.1$  (126), Indwell month 1:  $0.6 \pm 0.4$  (109), Stent removal:  $0.8 \pm 1.3$  (106), Post-removal month 6:  $0.8 \pm 1.2$  (66), Post-removal month 12:  $0.6 \pm 0.3$  (57), Post-removal month 24:  $1.0 \pm 2.1$  (24)

Alkaline phosphatase: Baseline:  $332 \pm 363$  (125), Indwell month 1:  $166 \pm 130$  (113), Stent removal:  $166 \pm 198$  (105), Post-removal month 6:  $142 \pm 151$  (67), Post-removal month 12:  $127 \pm 139$  (59), Post-removal month 24:  $136 \pm 115$  (25)

# WallFlex™ Biliary RX

## Fully Covered Stent System RMV

*Prescriptive Information*

Refer to the device directions for use for complete instructions on device use.

### Adverse Events

SAEs that have the potential to be device/procedure related occurred in 27.6% (35/127) of patients during stent placement, indwell, removal or biliary reintervention. SAEs that have the potential to be device/procedure related occurred in 14.2% (18/127) of patients during the post stent removal follow-up period. In total, 36.2% (46/127) ITT patients and 36.4% (43/118) PP patients experienced 86 events as detailed below. There were no stent or stent removal related deaths; however, 7 patients died during the stent indwell period and an additional 3 patients died during the follow-up period due to non-device/procedure related causes.

Table 1. Potentially device/procedure related SAEs

Stent placement, stent indwell, or biliary reintervention SAEs			Stent Removal		
SAE Term	Number of Events	Patient Incidence	SAE Term	Number of Events	Patient Incidence
Biliary leak	1	0.8% (1/127)	Cholangitis	3	2.4% (3/127)
Gas embolism	1	0.8% (1/127)	Abdominal pain	1	0.8% (1/127)
Abdominal pain	12	5.5% (7/127)	Post Stent Removal Follow-Up		
Pancreatitis	14	10.2% (13/127)	SAE Term	Number of Events	Patient Incidence
Cholecystitis	3	2.4% (3/127)	Biliary leak	1	0.8% (1/127)
Chest pain	1	0.8% (1/127)	Abdominal pain	4	3.1% (4/127)
Cholangitis	12	7.1% (9/127)	Pancreatitis	10	7.1% (9/127)
Cholelithiasis	1	0.8% (1/127)	Cholangitis	8	4.7% (6/127)
Cholestasis	2	1.6% (2/127)	Hepatic abscess	1	0.8% (1/127)
Stent placement, stent indwell, or biliary reintervention SAEs			Peripancreatic pseudocyst	1	0.8% (1/127)
SAE Term	Number of Events	Patient Incidence			
Peripancreatic abscess	1	0.8% (1/127)			
Insufficient pancreatic drainage	1	0.8% (1/127)			
Hepatic abscess	2	1.6% (2/127)			
Peripancreatic cyst/pseudocyst	3	2.4% (3/127)			
Sepsis	2	1.6% (2/127)			
Bacterial infection	1	0.8% (1/127)			

# WallFlex™ Biliary RX

## Fully Covered Stent System RMV

Prescriptive Information

Refer to the device directions for use for complete instructions on device use.

### Summary of Clinical Findings

Stent removability was possible after stent indwell ranging from 8 to 613 days. Key outcomes are summarized in Table 2 below for all ITT patients and PP patients, and for the subset of PP patients with endoscopic stent removal as scheduled after the intended stent indwell duration.

### Pre-Procedure Notes

Radiography of pertinent anatomy performed no more than 10 days before the procedure should be available.

Initial preparation of delivery system:

- Carefully remove the delivery system from the protective packaging.
- Visually inspect the device for damage or defects.
- Visually check that the leading end of the stent is covered by the exterior tube.
- Ensure that no stent wires have perforated the exterior tube.

Note: DO NOT remove the shipping mandrel from the leading end of the device (Figure 2), this will help facilitate guidewire access.

RO markers are used to aid in positioning the stent across the stricture.

During deployment, these RO markers indicate when the reconstraint limit is reached and when the stent is fully deployed. The RO markers are fully described in the Device Description section of these directions.

### Warranty

Boston Scientific Corporation (BSC) warrants that reasonable care has been used in the design and manufacture of this instrument. This warranty is in lieu of and excludes all other warranties not expressly set forth herein, whether express or implied by operation of law or otherwise, including, but not limited to, any implied warranties of merchantability or fitness for a particular purpose. Handling, storage, cleaning and sterilization of this instrument as well as other factors relating to the patient, diagnosis, treatment, surgical procedures and other matters beyond BSC's control directly affect the instrument and the results obtained from its use. BSC's obligation under this warranty is limited to the repair or replacement of this instrument and BSC shall not be liable for any incidental or consequential loss, damage or expense directly or indirectly arising from the use of this instrument. BSC neither assumes, nor authorizes any other person to assume for it, any other or additional liability or responsibility in connection with this instrument. BSC assumes no liability with respect to instruments reused, reprocessed or reesterilized and makes no warranties, express or implied, including but not limited to merchantability or fitness for a particular purpose, with respect to such instruments.

Table 2. Summary of Key Outcomes

Metric	ITT Patients	PP Patients	PP Patients with Endoscopic Stent Removal as Scheduled
Stent functionality during stent indwell	77.2% (98/127)	83.1% (98/118)	100% (95/95)
Stent Removability	72.4% (92/127)	78.0% (92/118)	96.8% (92/95)
Removal success	84.3% (107/127)	90.7% (107/118)	96.8% (92/95)
Stricture resolution	74.0% (94/127)	79.7% (94/118)	90.5% (86/95)
No stricture recurrence	85.1% (80/94)	85.1% (80/94)	87.2% (75/86)
SAEs (patients with at least one SAE)	36.2% (46/127)	36.4% (43/118)	29.5% (28/95)